



robert abbey  
fine lighting

2020



# Table of Contents

1	AARON	65	DOUGHNUT	129	PIERCE	193	JONATHAN ADLER PARKER
2	ABBEY BRONZE	66	DOUGHNUT	130	PIKE	194	JONATHAN ADLER RIO
3	ADDISON	67	DOUGHNUT	131	PLEXUS	195	JONATHAN ADLER RIO
4	ALBERT	68	ECHO	132	RANGER	196	JONATHAN ADLER SATURN
5	ALICE	69	ECHO	133	RAQUEL	197	JONATHAN ADLER SPUTNIK
6	ALLOY	70	ECHO	134	REAL SIMPLE	198	JONATHAN ADLER TOTEM
7	ANDRE	71	ELENA	135	REAL SIMPLE	199	JONATHAN ADLER VENTANA
8	ANDROMEDA	72	EMPIRE	136	RODERICK	200	JONATHAN ADLER VENTANA
9	ANDROMEDA	73	ENTERPRISE	137	RODERICK	201	JONATHAN ADLER VENTANA
10	ANENOME	74	FERDINAND	138	RUBIX	202	JONATHAN ADLER VERSAILLES
11	ANNA	75	FINEAS	139	SATURNIA	203	JONATHAN ADLER VERSAILLES
12	ANNIKA	76	FINEAS	140	SATURNIA	204	JONATHAN ADLER VERSAILLES
13	APOLLO	77	FINEAS	141	SATURNIA	205	JONATHAN ADLER VIENNA
14	ARCHER	78	FLETCHER	142	SIMON	206	JONATHAN ADLER VIENNA
15	ARTEMIS	79	FOUNDRY	143	SLOAN	207	WILLIAMSBURG CUSTIS
16	ATHENA	80	FRANKLIN	144	SOFIA	208	WILLIAMSBURG ETOILE
17	AUDREY	81	FUSION	145	SPECTURM	209	WILLIAMSBURG FINNIE
18	AXIOM	82	GEMMA	146	TIC-TAC-TOE	210	WILLIAMSBURG LIGHTFOOT
19	AXIS	83	GLASS HARRIET	147	TREBLE	211	WILLIAMSBURG ORLANDO
20	AXIS	84	GLORIA	148	TRIPLE GOURD	212	WILLIAMSBURG RANDOLPH
21	BANDIT	85	GOLIATH	149	TYRONE	213	WILLIAMSBURG SPOTSWOOD
22	BEAUX ARTS	86	GOSSAMER	150	VICTOR	214	WILLIAMSBURG TAZEWELL
23	BEEHIVE	87	GRAVITY	151	WAVY	215	WILLIAMSBURG TUCKER
24	BELVEDERE	88	HALO	152	WILTON	216	WILLIAMSBURG TYRIE
25	BLING	89	HARVEY	153	WONTON	217	MICHAEL BERMAN ATLAS
26	BLING	90	HELENA	154	WYATT	218	MICHAEL BERMAN BERKLEY
27	BLING	91	HELENA AL FRESCO	155	WYATT	219	MICHAEL BERMAN BOND
28	BLOX	92	HERON	156	ZOLTAR	220	MICHAEL BERMAN BRUT
29	BRADLEY	93	HORIZON	157	RICO ESPINET ARIAL	221	MICHAEL BERMAN BRUT
30	BRAXTON	94	HORIZON	158	RICO ESPINET BUMPER	222	MICHAEL BERMAN BRUT
31	BRIGHTON	95	HUDSON	159	RICO ESPINET BUSTER	223	MICHAEL BERMAN HADRIAN
32	BRONTE	96	HUGO	160	RICO ESPINET BUSTER	224	MICHAEL BERMAN NOLAN
33	BRONTE AL FRESCO	97	JACE	161	RICO ESPINET CANDELARIA	225	BULBS
34	BRUNO	98	JASMINE	162	RICO ESPINET LUA VESSEL	226	ATHENA/AUDREY CHART
35	BRUNO	99	JEANNIE	163	RICO ESPINET MARINA	227	DELILAH/DELTA CHART
36	BRYCE	100	JUNE	164	RICO ESPINET MILES	228	DOLLY CHART
37	CAMPBELL	101	JUNE	165	RICO ESPINET NINA	229	DOUBLE GOURD CHART
38	CECILIA	102	JUNO	166	RICO ESPINET OLINDA	230	FRANKLIN CHART
39	CEDRIC	103	KATE	167	RICO ESPINET OVO	231	FUSION/JASMINE CHART
40	CELESTE	104	KATE	168	RICO ESPINET RACER	232	HARVEY CHART
41	CELINE	105	KINETIC	169	RICO ESPINET SCOUT	233	JUNE CHART
42	CHASE	106	KOLEMAN	170	RICO ESPINET SHINTO	234	MASON CHART
43	CINCH	107	KOLEMAN	171	JONATHAN ADLER BIARRITZ	235	ORION CHART
44	COLE	108	LATITUDE	172	JONATHAN ADLER BRISTOL	236	PIKE CHART
45	COOPER	109	LEDGER	173	JONATHAN ADLER CANAAN	237	TRIPLE GOURD CHART
46	COSMOS	110	LINCOLN	174	JONATHAN ADLER CANAAN	238	VICTOR CHART
47	CRISTALLO	111	LOGAN	175	JONATHAN ADLER CAPRI	239	MICHAEL BERMAN ATLAS/HADRIAN/ NOLAN CHART
48	CURTIS	112	MARCEL	176	JONATHAN ADLER CERAMIC	240	TERMS AND CONDITIONS
49	DAL	113	MARGEAUX	177	JONATHAN ADLER CLARIDGE		
50	DAPHNE	114	MASON	178	JONATHAN ADLER GENEVA		
51	DECKER	115	MUSE	179	JONATHAN ADLER HARLEQUIN		
52	DECKER	116	NIKOLE	180	JONATHAN ADLER HAVANA		
53	DECKER	117	NOVA	181	JONATHAN ADLER HOLLYWOOD		
54	DECKER	118	OCULUS	182	JONATHAN ADLER JUPITER		
55	DELANY	119	OLIVER	183	JONATHAN ADLER MEURICE		
56	DELILAH	120	ORION	184	JONATHAN ADLER MEURICE		
57	DELTA	121	PEARL	185	JONATHAN ADLER MEURICE		
58	DEXTER	122	PEEK	186	JONATHAN ADLER MEURICE		
59	DIANA	123	PENELOPE	187	JONATHAN ADLER MILANO		
60	DIRECTOR	124	PENELOPE	188	JONATHAN ADLER MILANO		
61	DOLLY	125	PHOEBE	189	JONATHAN ADLER MILANO		
62	DOLLY	126	PHOEBE AL FRESCO	190	JONATHAN ADLER MONACO		
63	DOUBLE GOURD	127	PIERCE	191	JONATHAN ADLER MYKONOS		
64	DOUGHNUT	128	PIERCE	192	JONATHAN ADLER PARKER		



---

We are proud to present our new 2020 catalog to you, our loyal customers. We hope the information in this catalog inspires your creativity and promotes success.

Robert Abbey has always been about family. Our company continues to be family owned and operated for more than seven decades. We pride ourselves in the passion and dedication our founding members have instilled in us, while we look ahead at new possibilities and growth in an ever-changing market.

Robert Abbey is located in the foothills of Western North Carolina. Comprised of a 250,000 square foot facility ranging from offices, full manufacturing, and warehouse. We take pride in manufacturing an assortment of our diverse line in the USA. Continuing to manufacture products in the US has given Robert Abbey the flexibility to create fine lighting at an unparalleled value.

We are especially proud of our collaborations with top designers such as Jonathan Adler, Rico Espinet, Michael Berman, and Colonial Williamsburg who trust Robert Abbey to create lighting products that meet their high standards of quality and refinement.

Our showrooms in High Point and Dallas continue to be exciting arenas for collaboration and exchanging ideas. Our goal has always been to help ensure our customer's success. We look forward to your next visit to one of our showrooms.

Please continue to visit our website [www.robertabbey.com](http://www.robertabbey.com) for the latest product assortment and information.

Best regards,

Mary J Rose  
President

Nathan Hedrick  
Director of Operations

---

3166 MAIN AVENUE S.E. HICKORY, NC 28602 | 828.322.3480 | FAX 828.328.1037

PERMANENT SHOWROOMS

HIGHPOINT, NC W244 | DALLAS, TX WTC 305-1

[www.robertabbey.com](http://www.robertabbey.com)





703



646

# Aaron

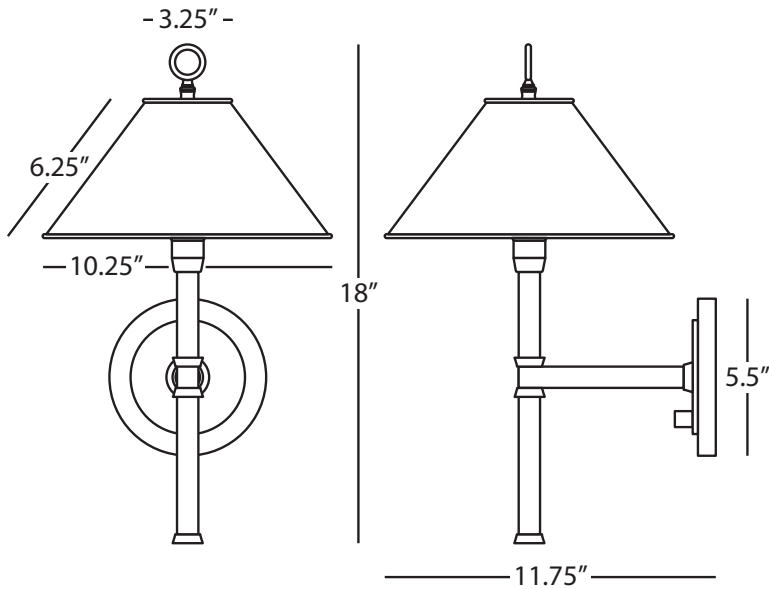

AARON

## 646 Wall Sconce

1 - 60W Max.  
Bulb Type: B, Candelabra Base  
Switch: Hi-Lo Dimming  
24" Cord Cover/Direct Wire  
Deep Patina Bronze Finish  
Warm Brass Accents  
Metal Shade

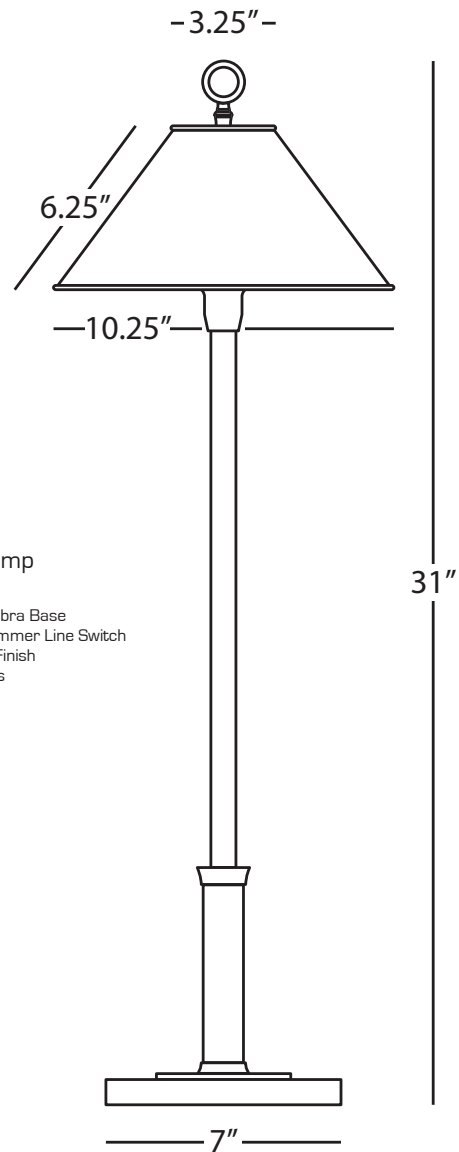

AARON

## 703 Buffet Table Lamp

1 - 60W Max.  
Bulb Type: B, Candelabra Base  
Switch: Full Range Dimmer Line Switch  
Deep Patina Bronze Finish  
Warm Brass Accents  
Metal Shade

# Abbey Bronze



L385X



L181



L180X



L386X



# Abbey Bronze

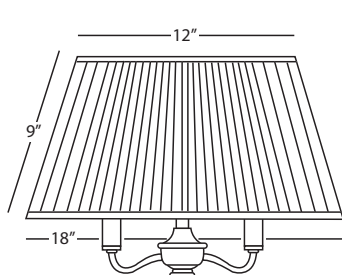

ABBEEY BRONZE

## L181 5-Way Floor Lamp

3 - 60W, 1 - 100W Max.  
Bulb Type: A  
Switch: 5-Way  
Victorian Bronze Finish  
Natural Crystal Pleat Fabric Shade

SHADE OPTION:

**L181X** Parchment Saki Fabric  
Dims: 14" x 18" x 9.5"

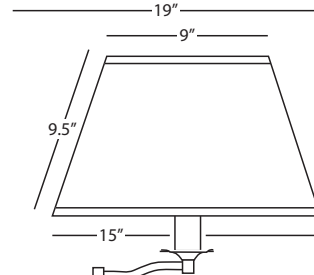
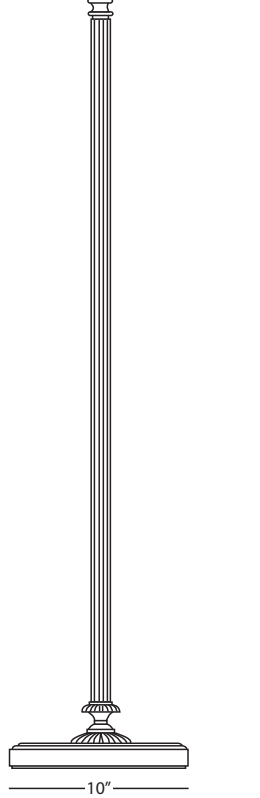

ABBEEY BRONZE

## L180X Swing Arm Floor Lamp

1 - 150W Max.  
Bulb Type: A  
Switch: 3-Way  
Victorian Bronze Finish  
Parchment Saki Fabric Shade

SHADE OPTION:

**L180** Natural Crystal Pleat Fabric  
Dims: 6" x 15" x 9.5"

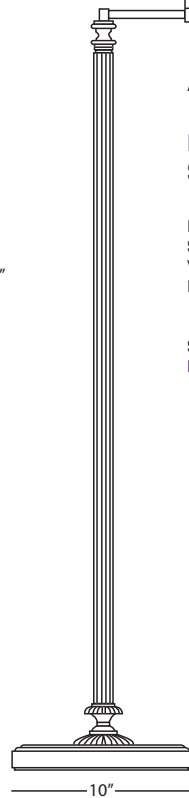

ABBEEY BRONZE

## L385X Swing Arm Table Lamp

1 - 60W Max.  
Bulb Type: A  
Switch: On-Off  
Victorian Bronze Finish  
Parchment Saki Fabric Shade

SHADE OPTION:

**L385** Natural Crystal Pleat Fabric  
Dims: 5" x 13" x 7"

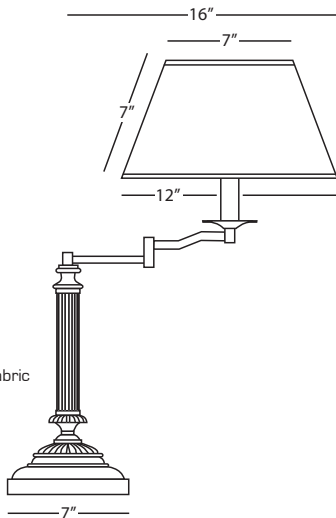

ABBEEY BRONZE

## L386X Column Table Lamp

1 - 150W Max.  
Bulb Type: A  
Switch: 3-Way  
Victorian Bronze Finish  
Parchment Saki Fabric Shade

SHADE OPTION:

**L386** Natural Crystal Pleat Fabric  
Dims: 6" x 14" x 9.5"

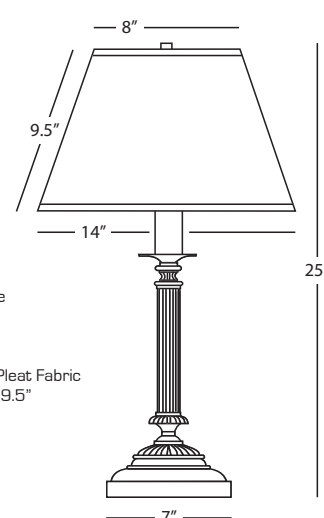



1573



1545

# Addison

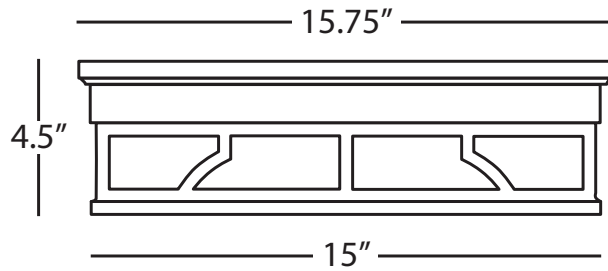

ADDISON

## 1573

Flush Mount

2 - 60W Max.  
Bulb Type: A  
Direct Wire  
Weathered Brass Finish  
White Glass Shade Panels

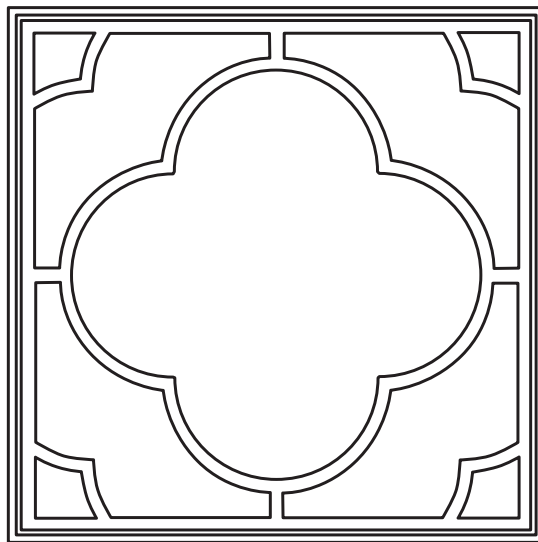

ADDISON

## 1545

Semi-Flush Mount

2 - 100W Max.  
Bulb Type: A  
Direct Wire  
Patina Nickel Finish  
Pearl Dupioni Fabric Shade  
w/ Decorative Metal Band  
17.5" Dia. White Acrylic Diffuser

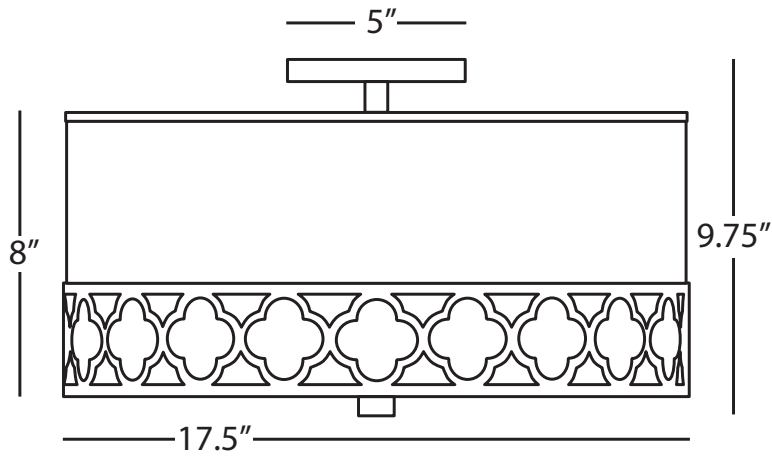

FINISH/SHADE OPTION:

1575 Weathered Brass  
Taupe Dupioni



S746



P743



P745



Z753



S744

# Albert

ALBERT

## Z753

### 3-Light Linear Pendant

3 - 60W Max.  
 Bulb Type: A  
 Direct Wire  
 Deep Patina Bronze Finish  
 Clear Glass Shades  
 Susp. Hardware: 12 Ft. Black Fabric  
 Wrapped Cord (x3)

Photographed with Historical Bulbs  
 SOLD SEPARATELY  
 (HIS01 (x3) See Page 225)

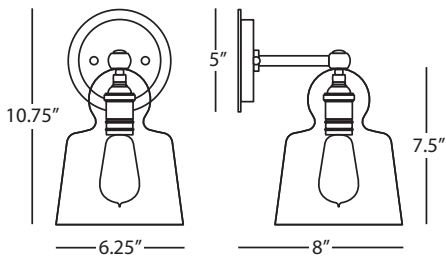
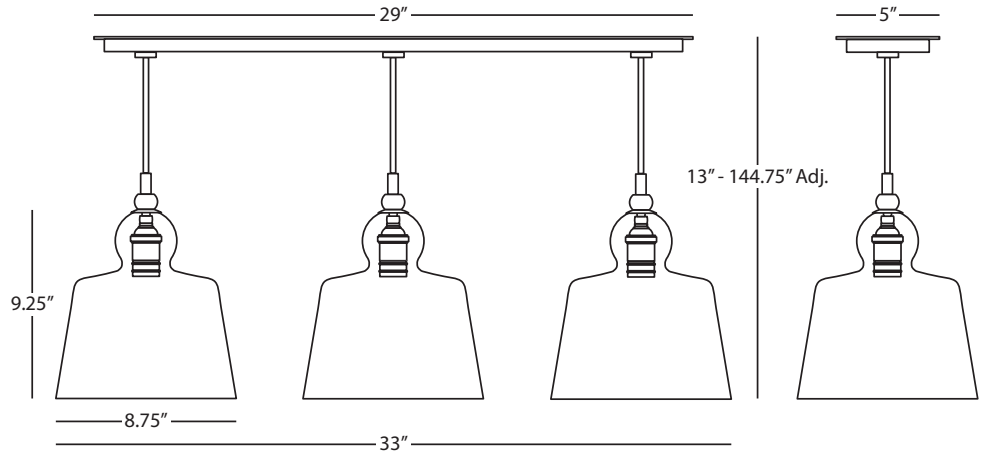

ALBERT

## P743

### 15" Pendant

1 - 100W Max.  
 Bulb Type: A  
 Direct Wire  
 Patina Nickel Finish  
 Clear Glass Shade  
 Susp. Hardware: 12 Ft. Black Fabric  
 Wrapped Cord

Photographed with Historical Bulb  
 SOLD SEPARATELY (Style # HIS01)  
 See Page 225)

FINISH OPTIONS:

**S743** Polished Nickel  
**Z743** Deep Patina Bronze

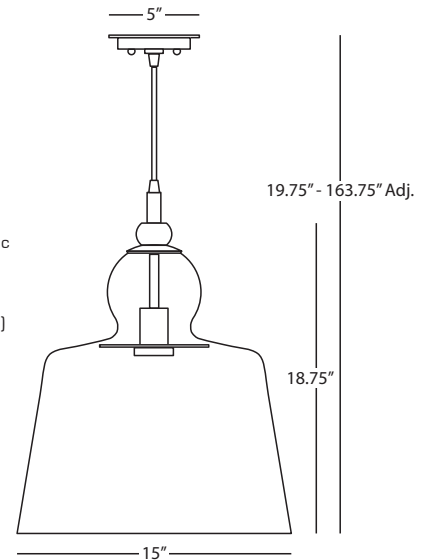

ALBERT

## P745

### Wall Sconce

1 - 60W Max.  
 Bulb Type: A  
 Direct Wire Only  
 Patina Nickel Finish  
 Clear Glass Shade

Ships with Historical Bulb  
 (HIS01 See page 225)

FINISH OPTIONS:

**S745** Polished Nickel  
**Z745** Deep Patina Bronze

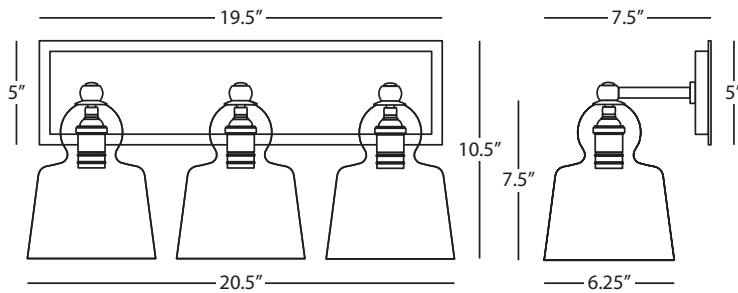

ALBERT

## P744

### Triple Sconce

3 - 60W Max.  
 Bulb Type: A  
 Direct Wire Only  
 Patina Nickel Finish  
 Clear Glass Shades

FINISH OPTIONS:

**S744** Polished Nickel  
**Z744** Deep Patina Bronze

ALBERT

## S746

### Pendant

1 - 100W Max.  
 Bulb Type: A  
 Direct Wire  
 Polished Nickel Finish  
 Clear Glass Shade  
 Susp. Hardware: 12 Ft. Black Fabric  
 Wrapped Cord

Ships with Historical Bulb  
 (HIS01 See page 225)

FINISH OPTIONS:

**P746** Patina Nickel  
**Z746** Deep Patina Bronze

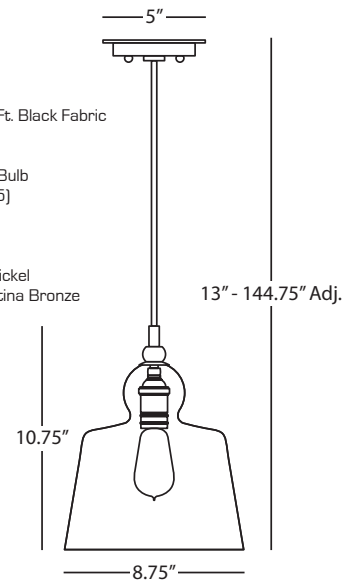



S3381



3381



S3380

# Alice

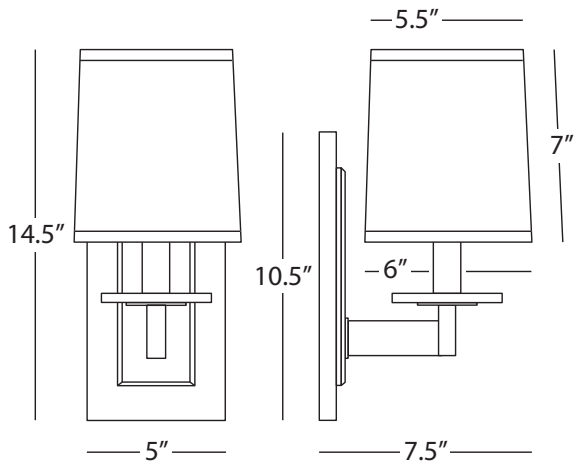

ALICE

## 3381 Wall Sconce

1 - 60W Max.  
Bulb Type: B, Candelabra  
Switch: On-Off Line Switch  
24" Cord Cover/Direct Wire  
Antique Brass Finish w/  
Lucite Accents  
Pearl Dupioni Fabric Shade

FINISH OPTION:  
**S3381** Polished Nickel

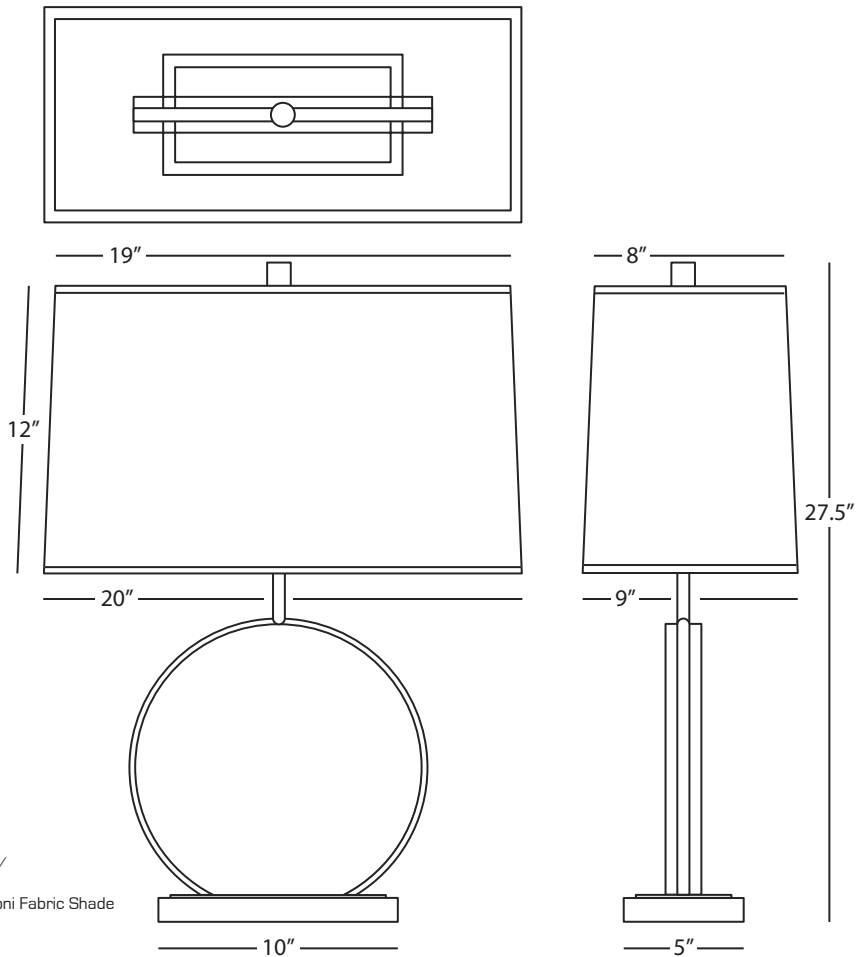

ALICE

## S3380 Table Lamp

1 - 150W Max.  
Bulb Type: A  
Switch: Hi-Lo Dimming  
Polished Nickel Finish w/  
Lucite Accents  
Rectangular Pearl Dupioni Fabric Shade



Z2418



S2418



2418



# Alloy

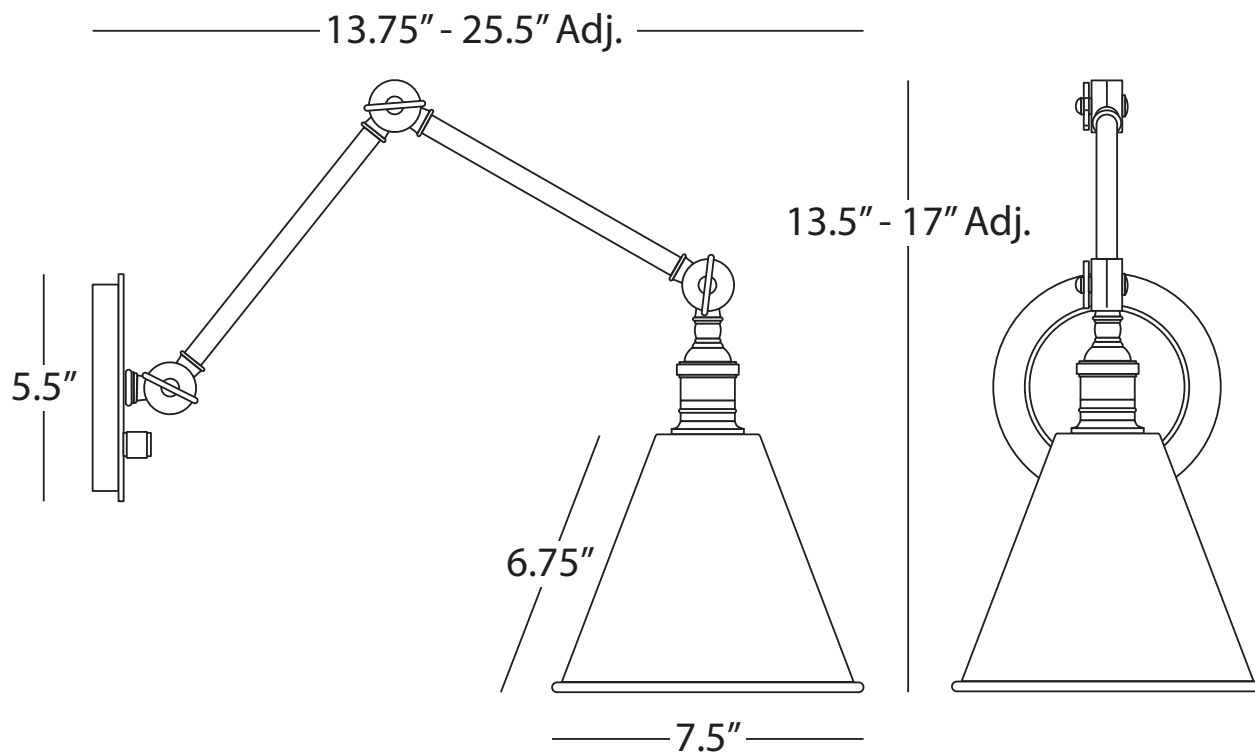

ALLOY

## 2418

### Adjustable Wall Sconce

1 - 60W Max.  
Bulb Type: A  
Switch: Hi-Lo Dimming  
24" Cord Cover/Direct Wire  
Warm Brass Finish  
Matching Metal Shade

#### FINISH OPTIONS:

**S2418** Polished Nickel  
**Z2418** Deep Patina Bronze



D3318



Z3318

Andre

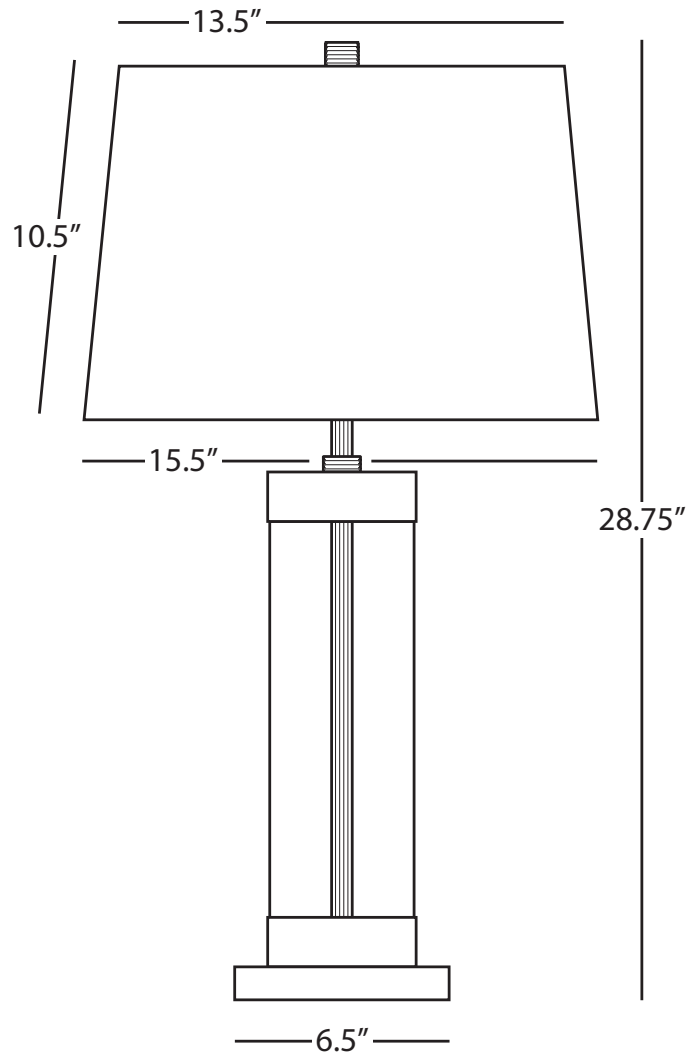

ANDRE

**D3318**

Table Lamp

1 - 150W Max.  
Bulb Type: A  
Switch: Full Range Dimmer  
Clear Glass Cylinder w/  
Dark Antique Nickel Accents  
Off-White Cotton Shade w/  
Rolled Edge Hem

FINISH OPTION:

**Z3318** Deep Patina Bronze



S165



S167



167



166

# Andromeda

ANDROMEDA

## 167 Flush Mount/Wall Sconce

4 - 40W Max.  
Bulb Type: G, Candelabra  
Direct Wire  
Modern Brass Finish  
Clear Acrylic Rods w/ Matching Metal Tips

FINISH OPTION:  
**S167** Polished Nickel

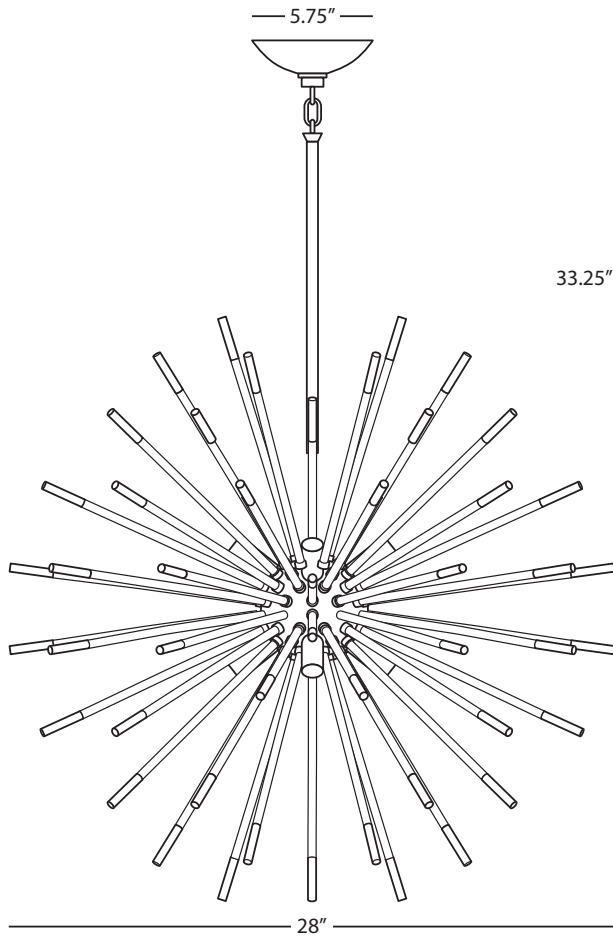
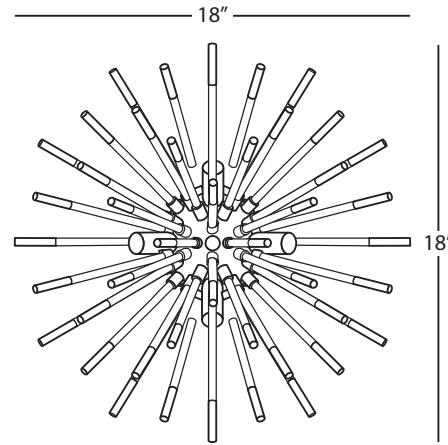
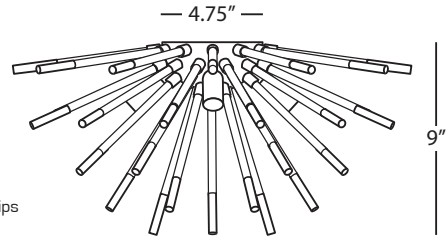

ANDROMEDA

## 166 Large Pendant

8 - 40W Max.  
Bulb Type: G, Candelabra  
Direct Wire  
Modern Brass Finish  
Clear Acrylic Rods w/ Matching Metal Tips  
Susp. Hardware: 1 pc. 1/2" x 6" &  
3 pcs. 1/2" x 12" Extensions

FINISH OPTION:  
**S166** Polished Nickel

ANDROMEDA

## S165 Small Pendant

8 - 40W Max.  
Bulb Type: G, Candelabra  
Direct Wire  
Polished Nickel Finish  
Clear Acrylic Rods w/ Matching Metal Tips  
Susp. Hardware: 1 pc. 1/2" x 6" &  
3 pcs. 1/2" x 12" Extensions

FINISH OPTION:  
**165** Modern Brass

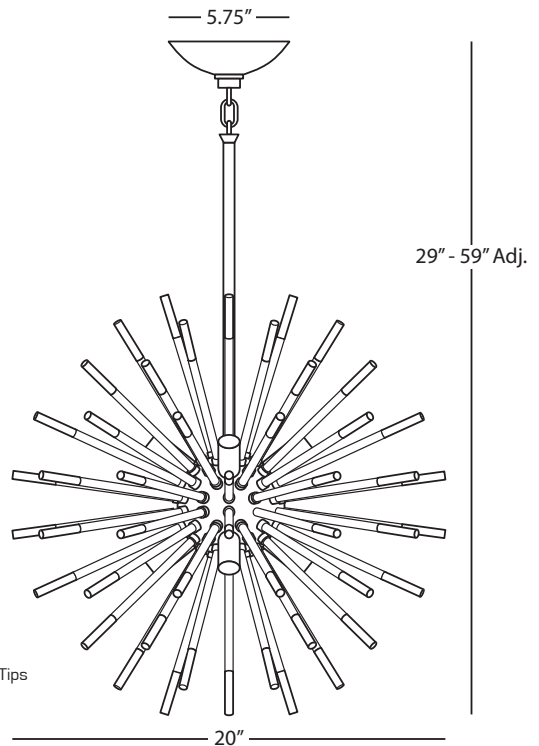



1200



1206



S1200

# Andromeda

ANDROMEDA

## 1200 Oval Chandelier

8 - 40W Max.  
Bulb Type: G, Candelabra  
Direct Wire  
Modern Brass Finish  
Clear Acrylic Rods w/ Matching Metal Tips  
Susp. Hardware: 1 pc. 1/2" x 6" & 3 pcs. 1/2" x 12" Extensions

FINISH OPTION:  
**S1200** Polished Nickel

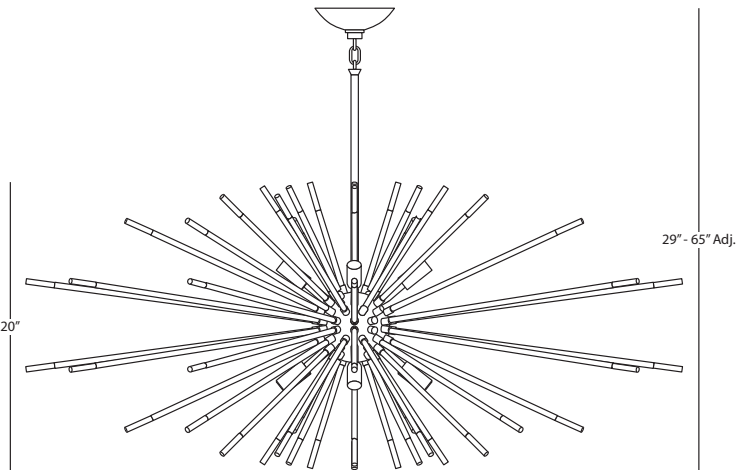
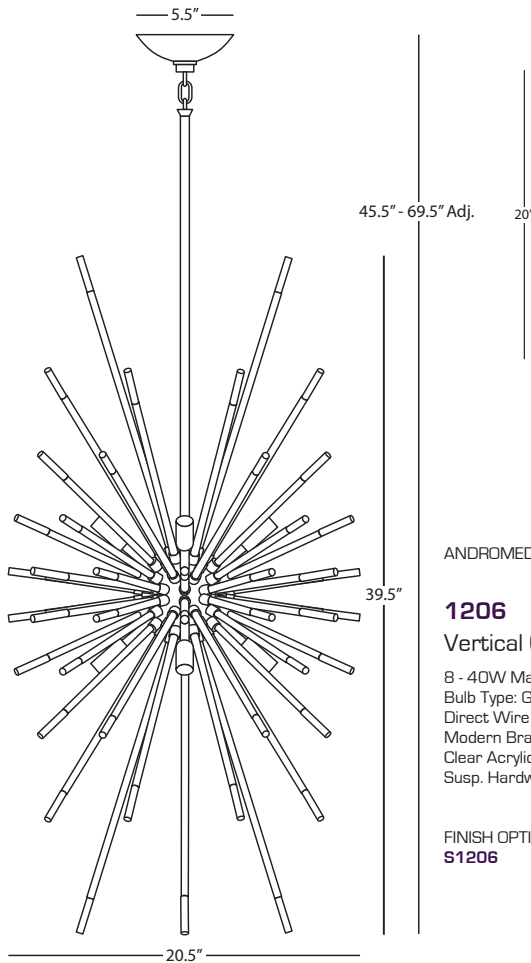
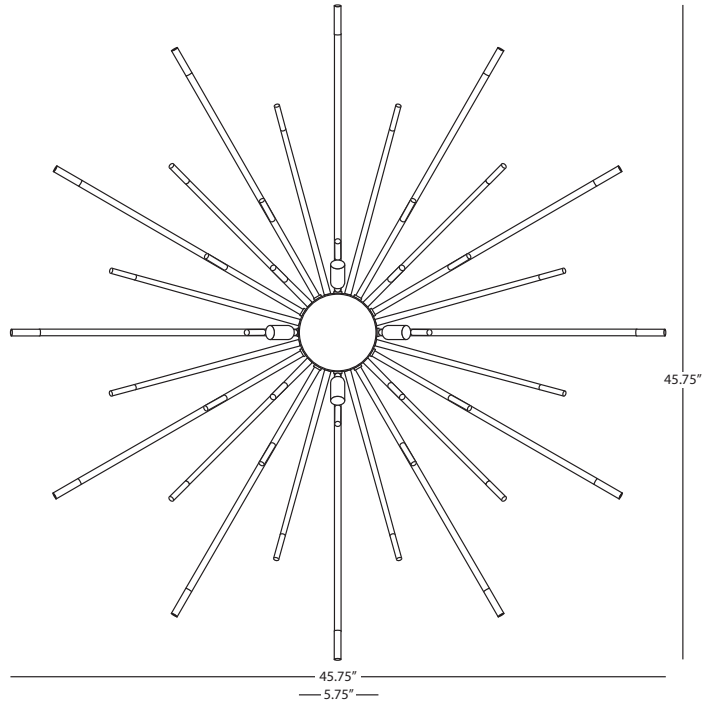

ANDROMEDA

## 1206 Vertical Chandelier

8 - 40W Max.  
Bulb Type: G, Candelabra Base  
Direct Wire  
Modern Brass Finish w/  
Clear Acrylic Rods with Matching Metal Tips  
Susp. Hardware: 1 pc. 1/2" x 6" & 3 pcs. 1/2" x 12" Extensions

FINISH OPTION:  
**S1206** Polished Nickel



S1305



S1305



S1306



# Anemone

ANEMONE

## S1305

Small Flush Mount/Wall Sconce

1 - 60W Max.  
Bulb Type: A, Silver Tip  
Direct Wire Only  
Polished Nickel Finish

Ships with Silver Tip Bulb  
[BULO1 See page 225]

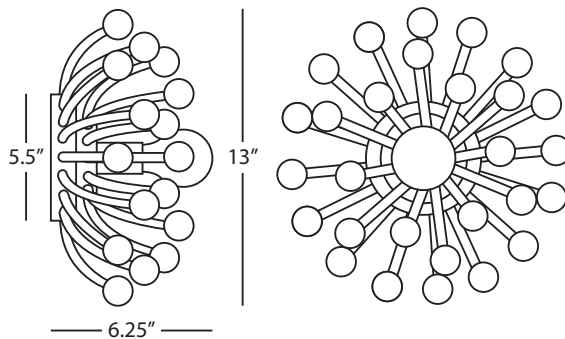

ANEMONE

## S1306

Large Flush Mount/Wall Sconce

5 - 60W Max.  
Bulb Type: A, Silver Tip  
Direct Wire Only  
Polished Nickel Finish

Ships with Five Historical Bulbs  
[BULO1 (x5) See Page 225]

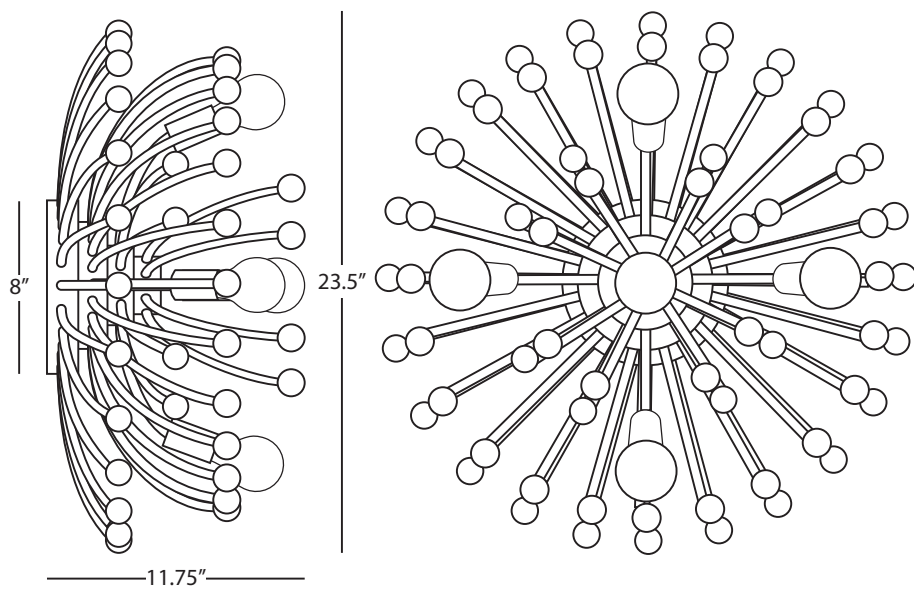



N898



897

# Anna

ANNA

## 897 Cube Table Lamp

1 - 150W Max.  
Bulb Type: A  
Switch: Hi-Lo Dimming  
Faux Brown Snakeskin Wrapped Base  
w/ Aged Brass Accents  
Taupe Dupioni Fabric Shade w/  
Self-Fabric Top Diffuser

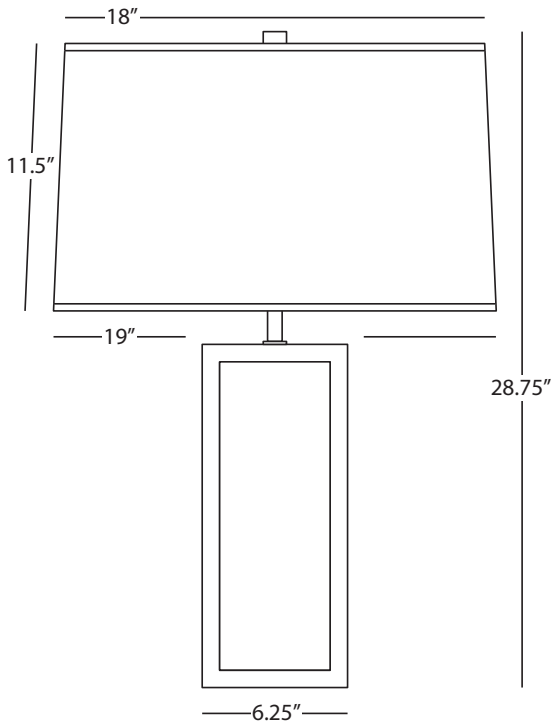
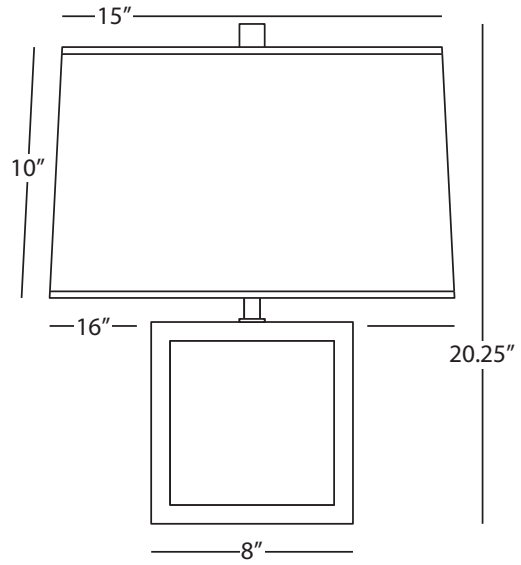
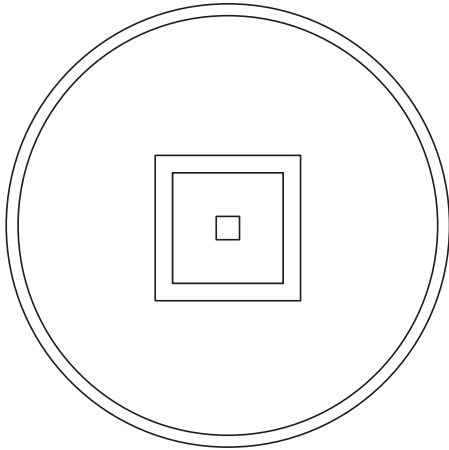
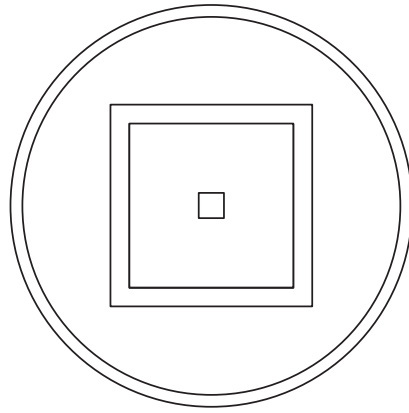

ANNA

## N898 Rectangular Table Lamp

1 - 150W Max.  
Bulb Type: A  
Switch: Hi-Lo Dimming  
Faux Navy Snakeskin Wrapped Base w/  
Polished Brass Accents  
Pearl Dupioni Fabric Shade

FINISH/SHADE OPTION:  
**898** Faux Brown Snakeskin w/  
Aged Brass Accents  
Taupe Dupioni Fabric



2506X



2605



2504



2604X



2501



2503X



2600

# Annika

MARY MCDONALD ANNIKA

## 2506X

### Accent Lamp

1 - 60W Max.  
 Bulb Type: B, Candelabra  
 Switch: On-Off Line Switch  
 Chocolate Lacquered Paint w/  
 Natural Brass & Ivory Crackle Accents  
 Cloud Cream Silk Shade

#### FINISH/SHADE OPTIONS:

- 2504** Cobalt Lacquered Paint  
Cobalt Painted Parchment Shade
- 2504X** Cobalt Lacquered Paint  
Cloud Cream Silk Shade
- 2505** Red Lacquered Paint  
Red Painted Parchment Shade
- 2505X** Red Lacquered Paint  
Cloud Cream Silk Shade
- 2506** Chocolate Lacquered Paint  
Chocolate Painted Parchment Shade
- 2507** Black Lacquered Paint  
Black Painted Parchment Shade
- 2507X** Black Lacquered Paint  
Cloud Cream Silk Shade
- 2603** Tangerine Lacquered Paint  
Tangerine Painted Parchment Shade
- 2603X** Tangerine Lacquered Paint  
Cloud Cream Silk Shade
- 2604** Ivory Lacquered Paint  
Ivory Painted Parchment Shade
- 2604X** Ivory Lacquered Paint  
Cloud Cream Silk Shade
- 2605** Blush Lacquered Paint  
Blush Painted Parchment Shade
- 2605X** Blush Lacquered Paint  
Cloud Cream Silk Shade

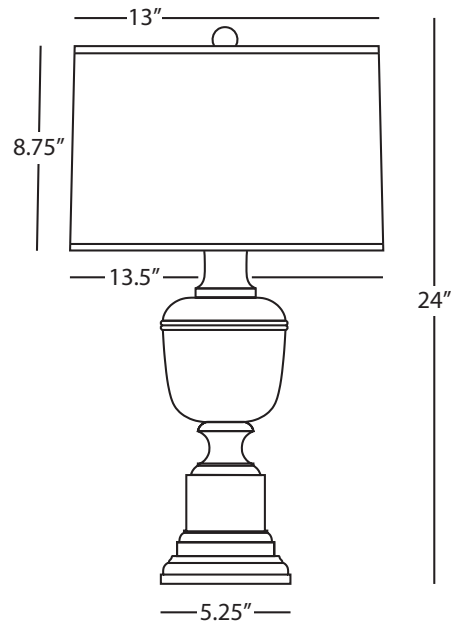

MARY MCDONALD ANNIKA

## 2501

### Table Lamp

1 - 150W Max.  
 Bulb Type: A  
 Switch: 3-Way  
 Red Lacquered Paint w/  
 Natural Brass & Ivory Crackle Accents  
 Red Painted Opaque Parchment Shade w/ Matte Gold Lining

#### FINISH/SHADE OPTIONS:

- 2500** Cobalt Lacquered Paint  
Cobalt Painted Parchment Shade
- 2500X** Cobalt Lacquered Paint  
Cloud Cream Silk Shade
- 2501X** Red Lacquered Paint  
Cloud Cream Silk Shade
- 2502** Chocolate Lacquered Paint  
Chocolate Painted Parchment Shade
- 2502X** Chocolate Lacquered Paint  
Cloud Cream Silk Shade
- 2503** Black Lacquered Paint  
Black Painted Parchment Shade
- 2503X** Black Lacquered Paint  
Cloud Cream Silk Shade
- 2600** Tangerine Lacquered Paint  
Tangerine Painted Parchment Shade
- 2600X** Tangerine Lacquered Paint  
Cloud Cream Silk Shade
- 2601** Ivory Lacquered Paint  
Ivory Painted Parchment Shade
- 2601X** Ivory Lacquered Paint  
Cloud Cream Silk Shade
- 2602** Blush Lacquered Paint  
Blush Painted Parchment Shade
- 2602X** Blush Lacquered Paint  
Cloud Cream Silk Shade

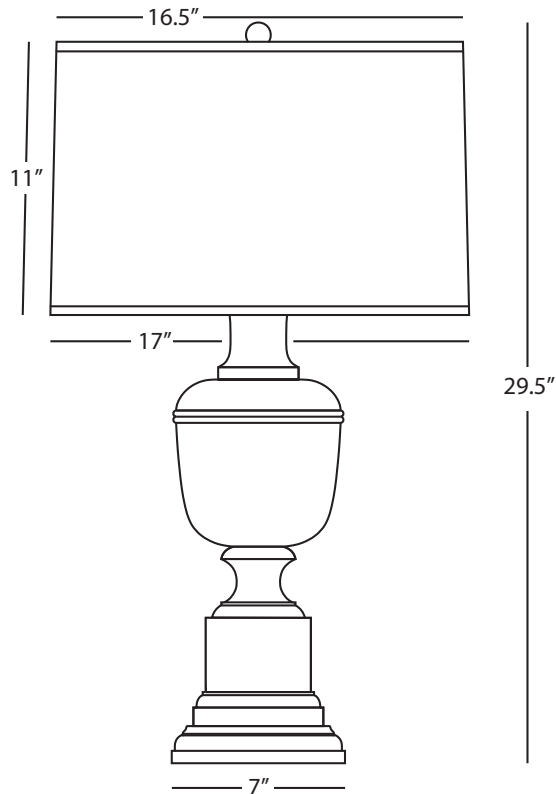



1582

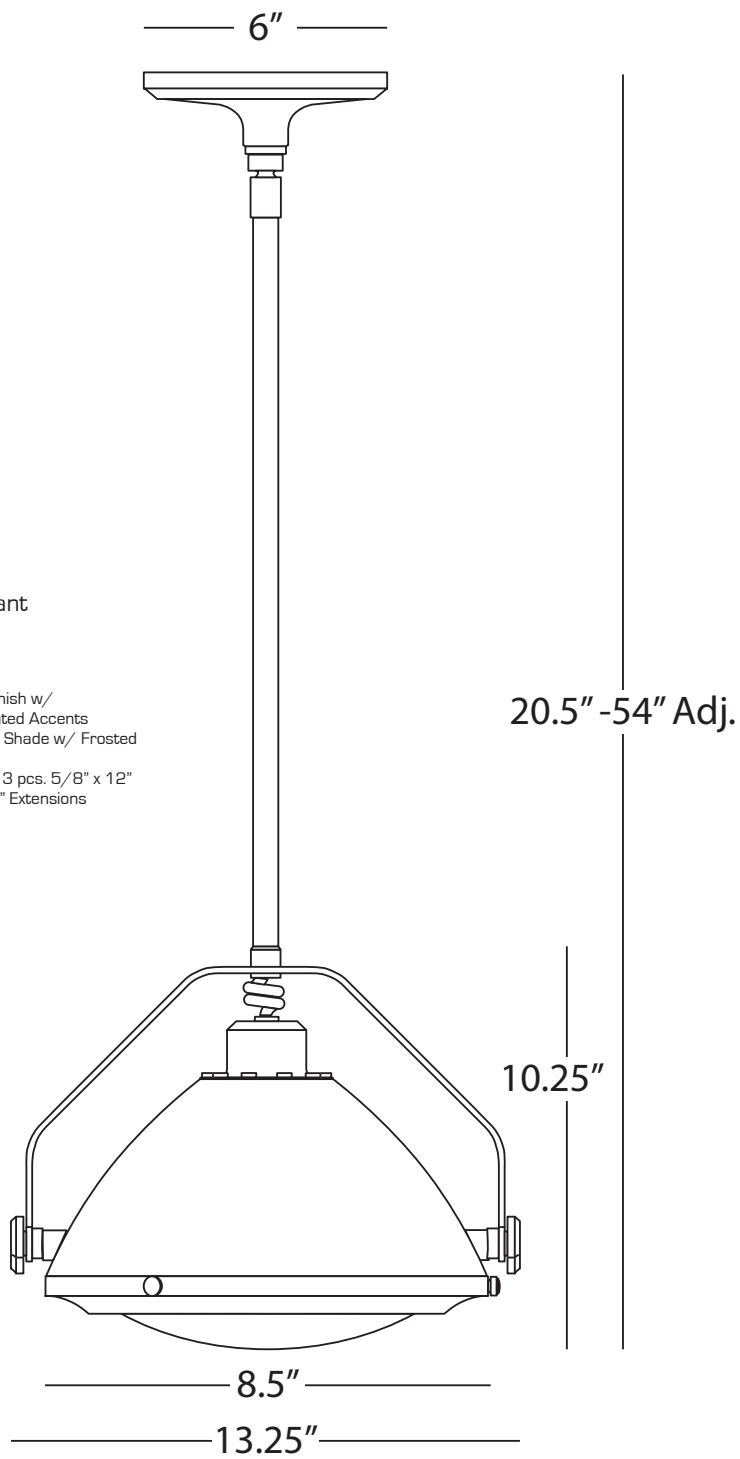

APOLLO

**1582**

**Small Pendant**

1 - 60W Max.  
Bulb Type: A  
Direct Wire  
Antique Brass Finish w/  
Matte Black Painted Accents  
Adjustable Metal Shade w/ Frosted  
Glass Diffuser  
Susp. Hardware: 3 pcs. 5/8" x 12"  
& 1 pc. 5/8" x 6" Extensions



S2286



2287



# Archer

ARCHER

## 2287 Small Floor Lamp

2 - 100W Max.  
Bulb Type: A  
Switch: Full Range Dimmer Foot Switch  
Warm Brass Finish  
Carrara Marble Base  
White Brussels Linen Shade w/  
Self-Fabric Bottom Diffuser

FINISH OPTION:  
**S2287** Polished Nickel

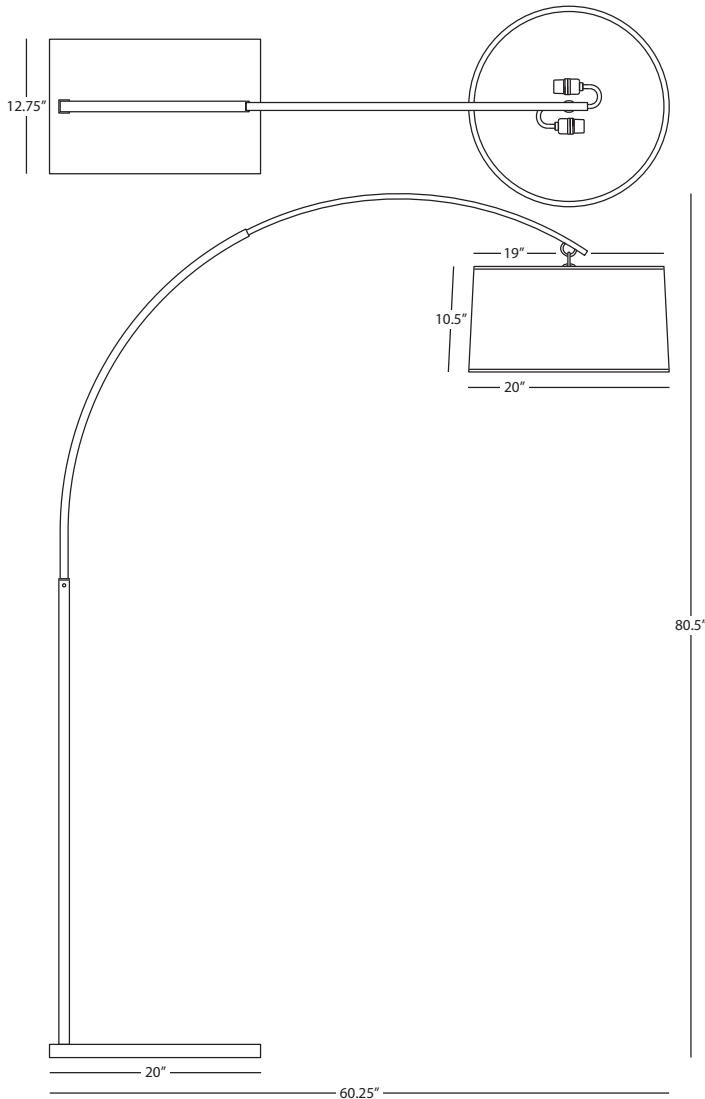
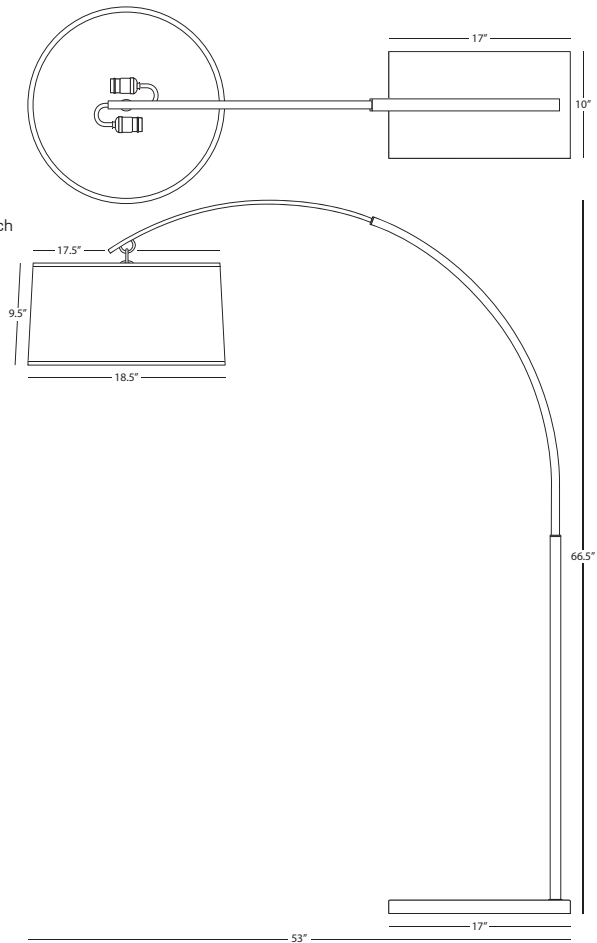

ARCHER

## S2286 Floor Lamp

2 - 150W Max.  
Bulb Type: A  
Switch: Full Range Dimmer Foot Switch  
Polished Nickel Finish  
Carrara Marble Base  
White Brussels Linen Shade w/  
Self-Fabric Bottom Diffuser

FINISH OPTION:  
**2286** Warm Brass



3329



3324W



3324B

# Artemis

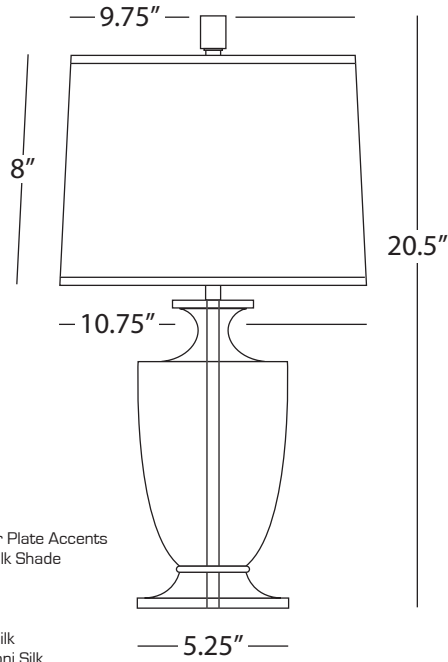

ARTEMIS

**3329**

Accent Lamp

1 - 60W Max.  
 Bulb Type: B11 Torpedo  
 Switch: Full Range Dimmer  
 Clear Lead Crystal w/ Silver Plate Accents  
 Rectangular Cafe Dupioni Silk Shade

SHADE OPTIONS:

**3329B** Black Dupioni Silk  
**3329W** Off-White Dupioni Silk

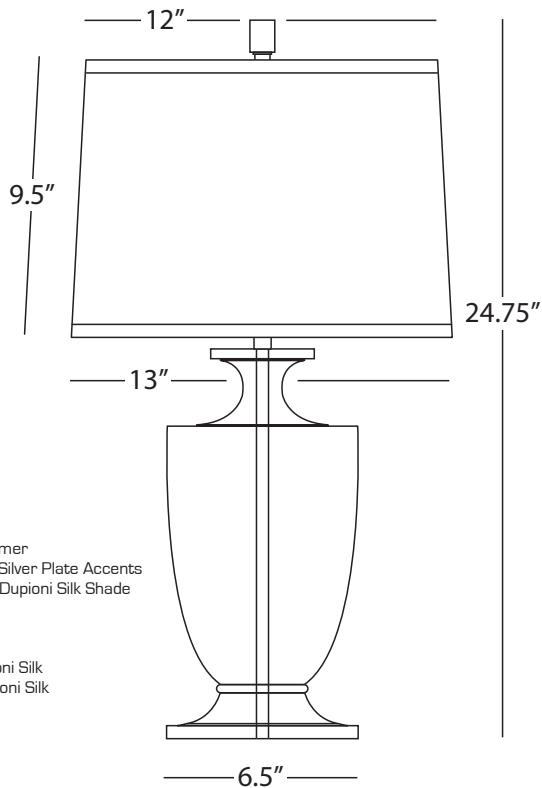
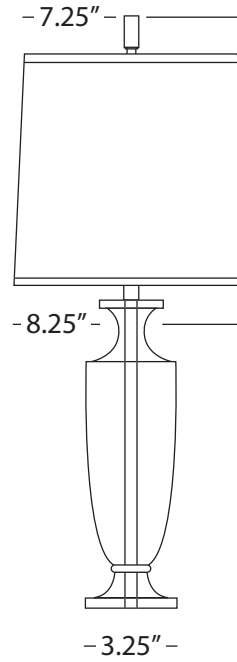

ARTEMIS

**3324W**

Table Lamp

1 - 150W Max.  
 Bulb Type: A  
 Switch: Full Range Dimmer  
 Clear Lead Crystal w/ Silver Plate Accents  
 Rectangular Off-White Dupioni Silk Shade

SHADE OPTIONS:

**3324** Cafe Dupioni Silk  
**3324B** Black Dupioni Silk

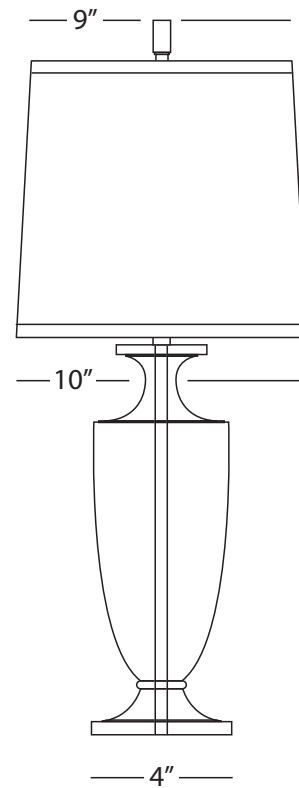



ML992



BN992



PC992



EG992



CI992



CR992

# Athena

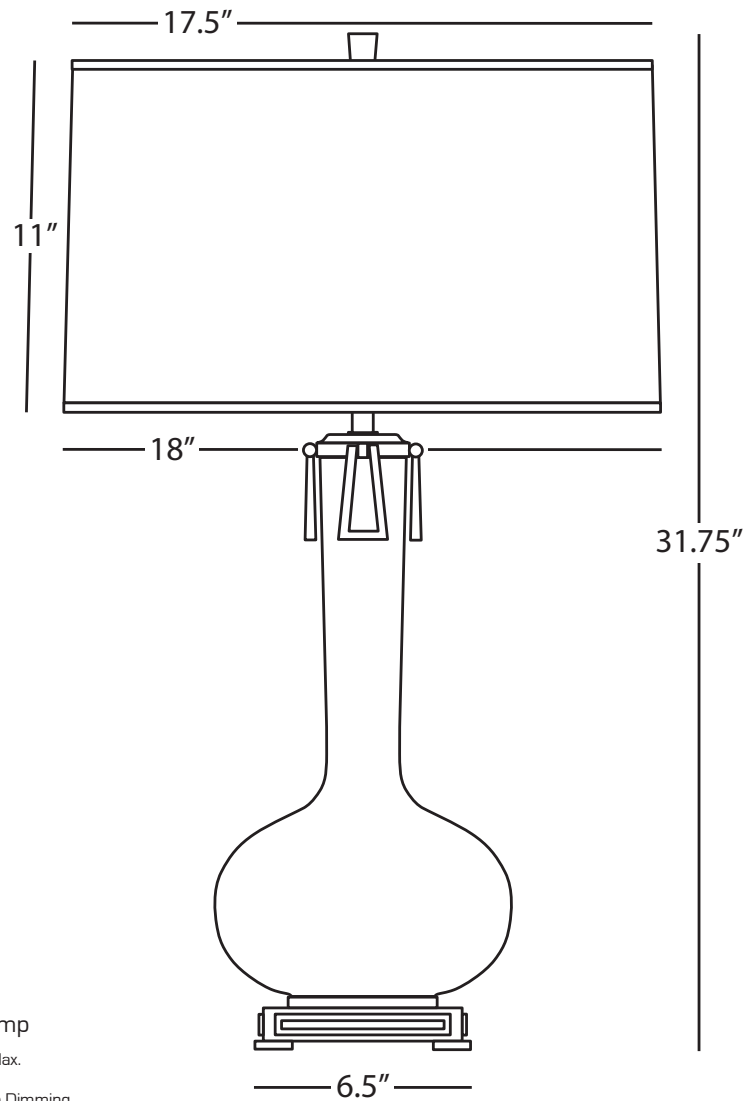

ATHENA

**CI992**

Table Lamp

1 - 150W Max.

Bulb Type: A

Switch: Hi-Lo Dimming

Citron Glazed Ceramic

Cast Metal Base and Ring Details

Aged Brass Finish

Open Weave Heather Linen Shade

See Page 226 for Color Options



LY980



ST980



PC980



MB980



MR980

# Audrey

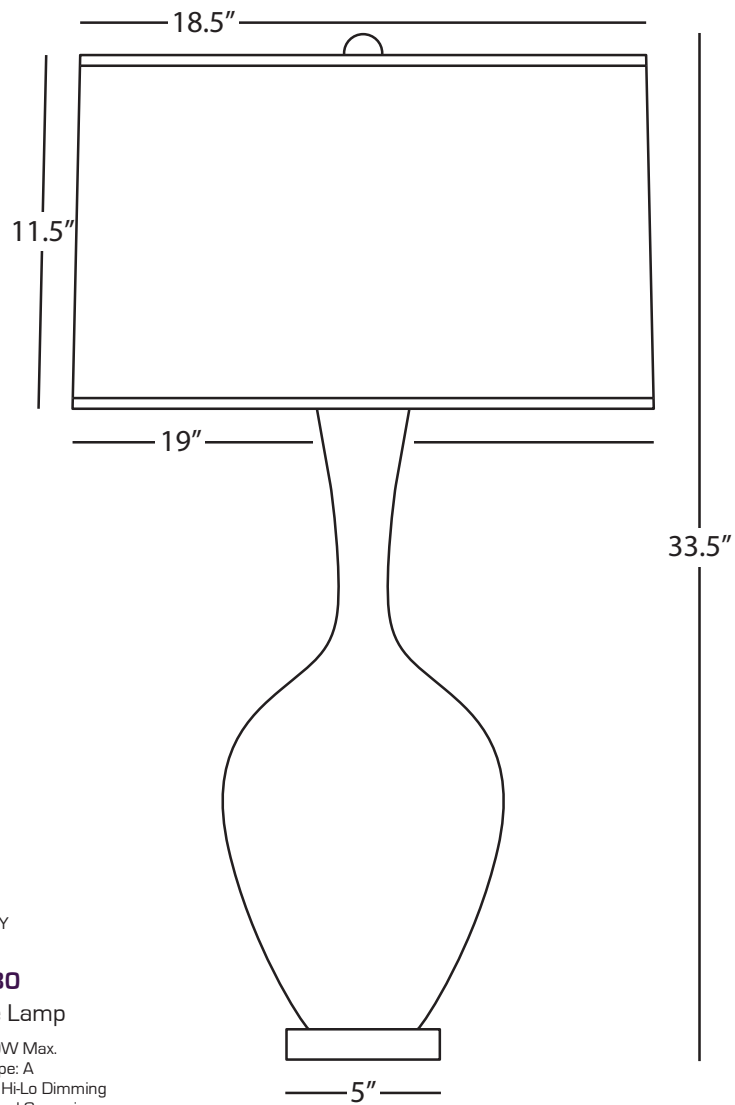

AUDREY

## LY980

Table Lamp

1 - 150W Max.  
Bulb Type: A  
Switch: Hi-Lo Dimming  
Lily Glazed Ceramic  
Lucite Base  
Fondine Fabric Shade

See Page 226 for Color Options



3390



B3390



S3390



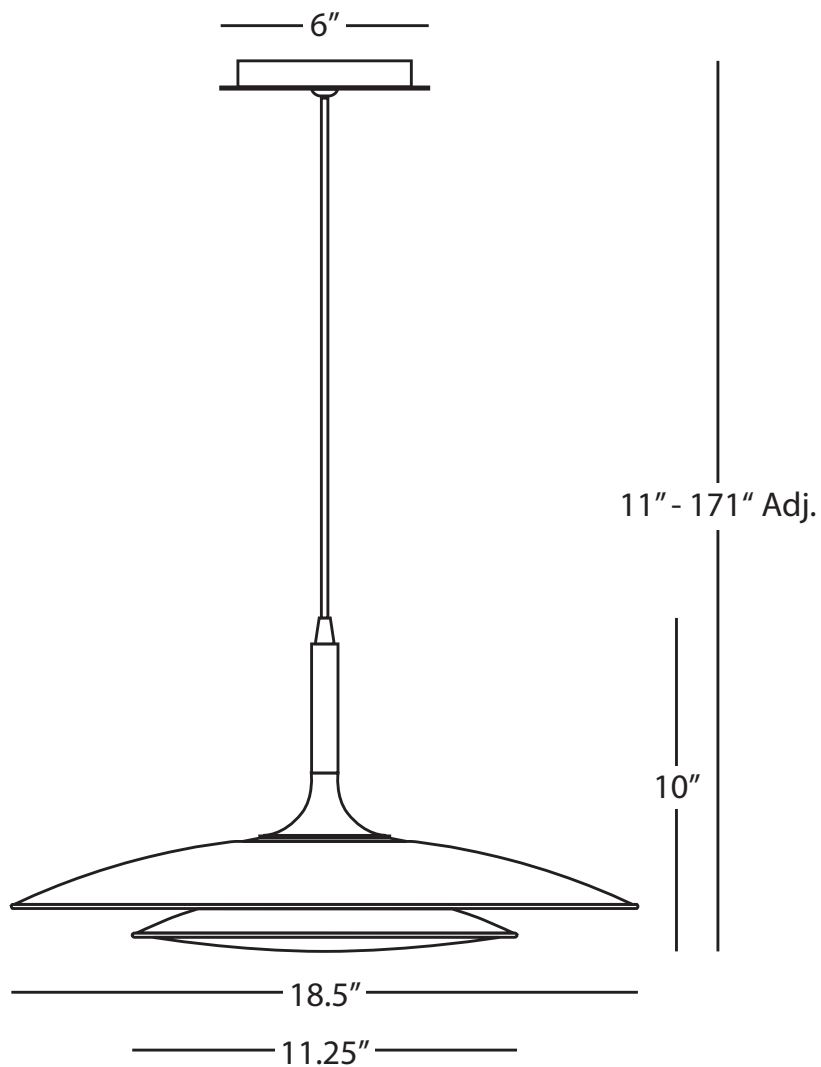

AXIOM

## 3390

### Pendant

3 - 35W Max.  
Bulb Type: 120V G6.35 Bi-Pin Halogen  
Bulbs Included  
Direct Wire  
Polished Gold Finish  
Frosted, White Cased Glass Diffuser  
Susp. Hardware: 160" Black Fabric  
Wrapped Cord

#### FINISH OPTIONS:

**B3390** Gloss Black  
**S3390** Polished Nickel



2134



2136

# Axis

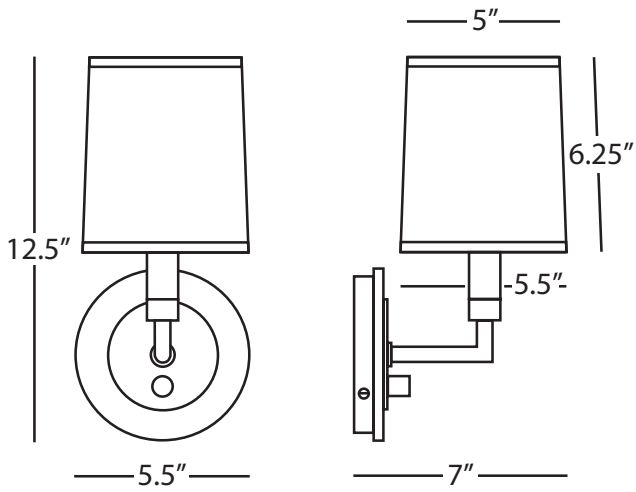

AXIS

## 2136 Single Sconce

1 - 60W Max.  
Bulb Type: B, Candelabra  
Switch: On-Off  
24" Cord Cover / Direct Wire  
Aged Brass Finish w/  
Cocoa Brown Accents  
Honed Travertine Back Plate  
Fondine Fabric Shade w/  
Black Contrasting Trim

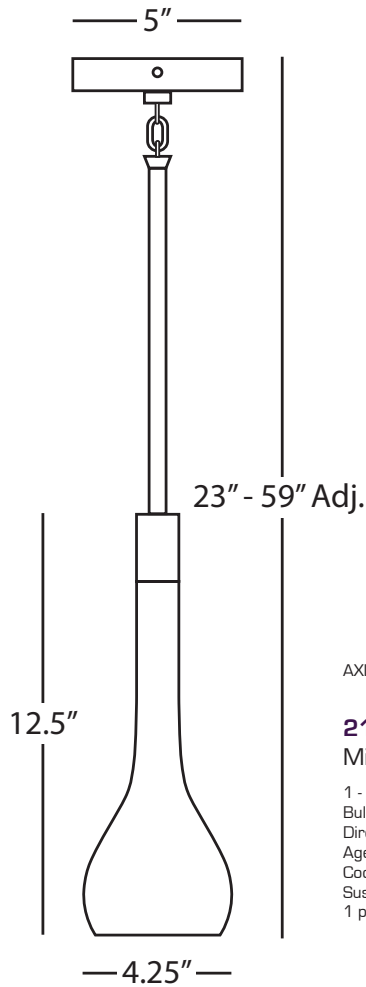

AXIS

## 2134 Mini Pendant

1 - 60W Max.  
Bulb Type: G16.5 Candelabra  
Direct Wire Only  
Aged Brass Finish w/  
Cocoa Brown Accents  
Susp. Hardware: 3 pcs. 1/2" x 12" &  
1 pc. 1/2" x 6" Extensions



D2139



2200



D2201

# Axis

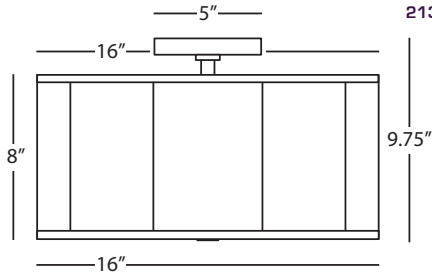
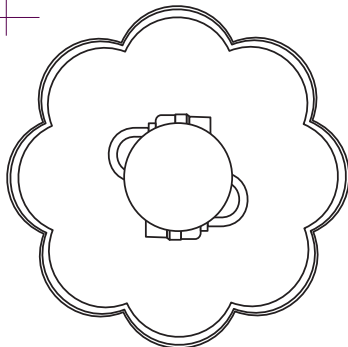

AXIS

## D2139 16" Semi-Flush Mount

2 - 100W Max.  
Bulb Type: A  
Direct Wire  
Blackened Antique Nickel Finish  
Scalloped Ascot White Fabric Shade w/  
Black Contrasting Trim  
15" Dia. White Acrylic Diffuser

FINISH/SHADE OPTION:  
**2139** Aged Brass  
Fondine Shade w/  
Black Contrasting Trim

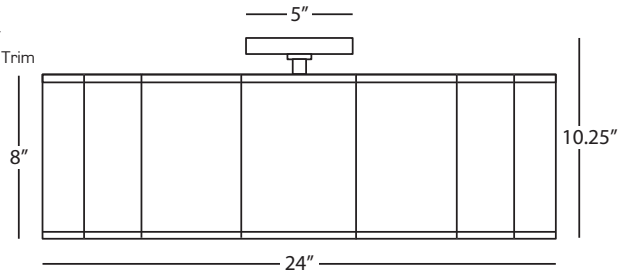
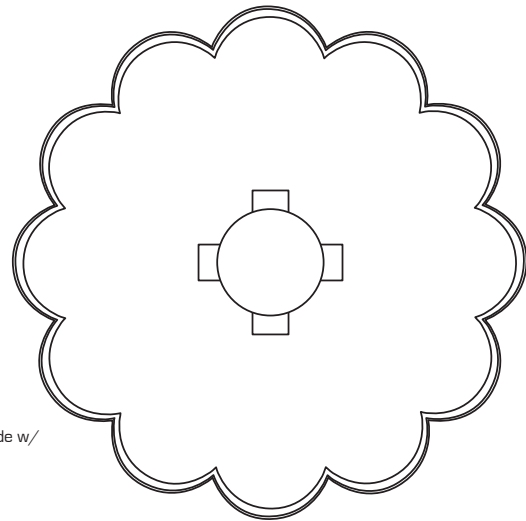

AXIS

## D2201 24" Semi-Flush Mount

4 - 100W Max.  
Bulb Type: A  
Direct Wire  
Blackened Antique Nickel Finish  
Scalloped Ascot White Fabric Shade w/  
Black Contrasting Trim  
23" Dia. White Acrylic Diffuser

FINISH/SHADE OPTION:  
**2201** Aged Brass  
Fondine Shade w/  
Black Contrasting Trim

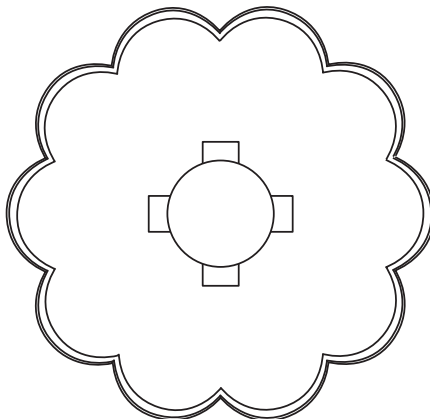
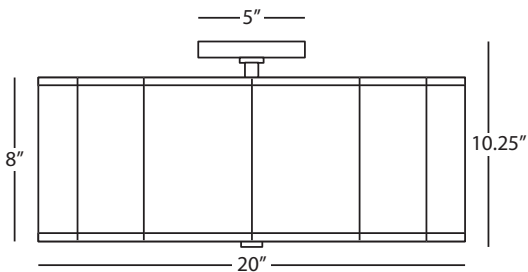

AXIS

## D2200 20" Semi-Flush Mount

4 - 100W Max.  
Bulb Type: A  
Direct Wire  
Aged Brass Finish  
Scalloped Fondine Fabric Shade w/  
Black Contrasting Trim  
19" Dia. White Acrylic Diffuser

FINISH/SHADE OPTION:  
**D2200** Blackened Antique Nickel  
Ascot White Fabric w/  
Black Contrasting Trim



Z348



S349



Z347

# Bandit

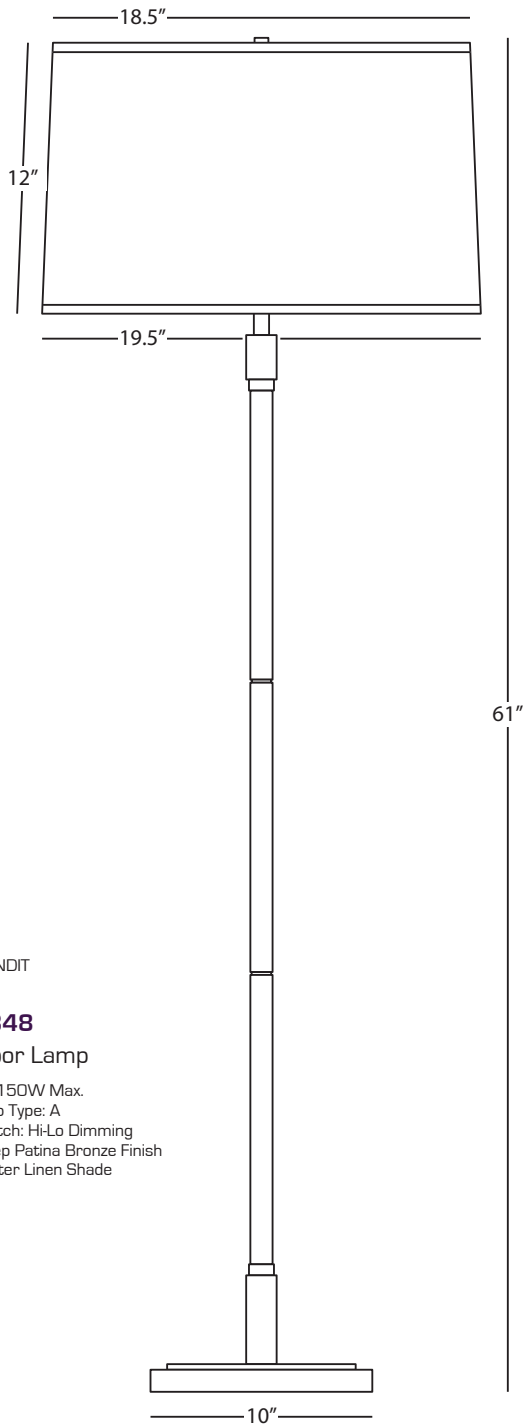

BANDIT

## Z348

### Floor Lamp

1 - 150W Max.  
 Bulb Type: A  
 Switch: Hi-Lo Dimming  
 Deep Patina Bronze Finish  
 Oyster Linen Shade

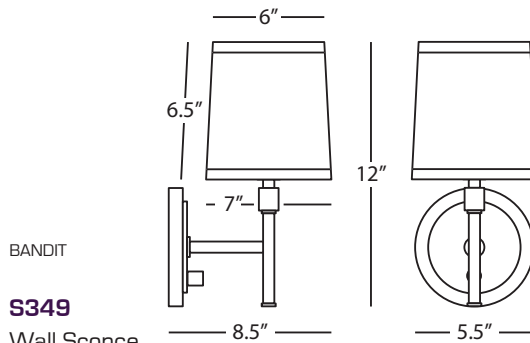

BANDIT

## S349

### Wall Sconce

1 - 60W Max.  
 Bulb Type: B, Candelabra  
 Switch: Hi-Lo Dimming  
 24" Cord Cover/Direct Wire  
 Polished Nickel Finish  
 Oyster Linen Shade

FINISH OPTION:

**Z349** Deep Patina Bronze

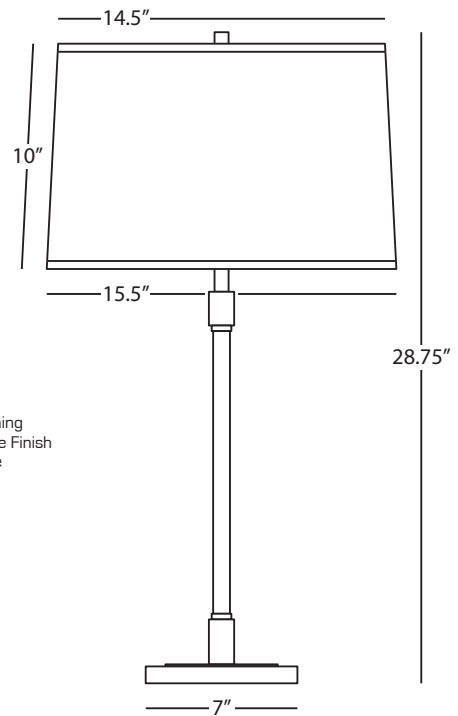

BANDIT

## Z347

### Table Lamp

1 - 150W Max.  
 Bulb Type: A  
 Switch: Hi-Lo Dimming  
 Deep Patina Bronze Finish  
 Oyster Linen Shade



9824BRN



9857X



9867B



9866



9856



# Beaux Arts

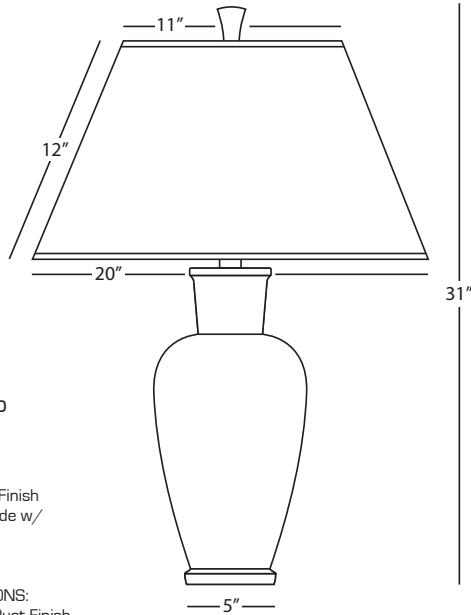

BEAUX ARTS

## 9867B Urn Table Lamp

1 - 150W Max.  
Bulb Type: A  
Switch: 3-Way  
Dark Antique Copper Finish  
Black Parchment Shade w/  
Matte Gold Lining

FINISH/SHADE OPTIONS:

- 9857**   Antique Rust Finish  
          Golden Saki Fabric
- 9857X**   Antique Rust Finish  
          Translucent Flax Parchment
- 9867**    Dark Antique Copper Finish  
          Oyster Linen

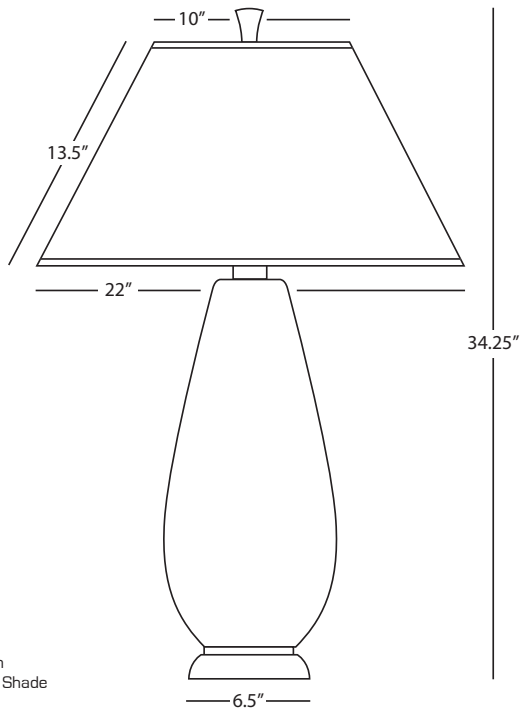

BEAUX ARTS

## 9856 Table Lamp

1 - 150W Max.  
Bulb Type: A  
Switch: 3-Way  
Antique Rust Finish  
Golden Saki Fabric Shade

FINISH/SHADE OPTIONS:

- 9856X**   Antique Rust Finish  
          Translucent Flax Parchment
- 9866**    Dark Antique Copper Finish  
          Oyster Linen
- 9866B**   Dark Antique Copper Finish  
          Black Parchment w/  
          Matte Gold Lining

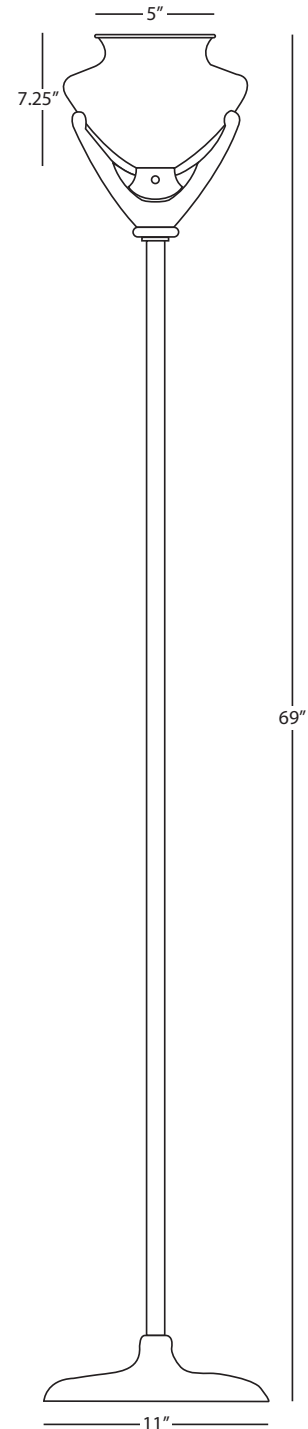

BEAUX ARTS

## 9824BRN Floor Torchere

1 - 150W Max.  
Bulb Type: A  
Switch: 3-Way  
Antiqued Rust Finish  
Frosted, Amber Seeded Glass Shade



N616

# Beehive

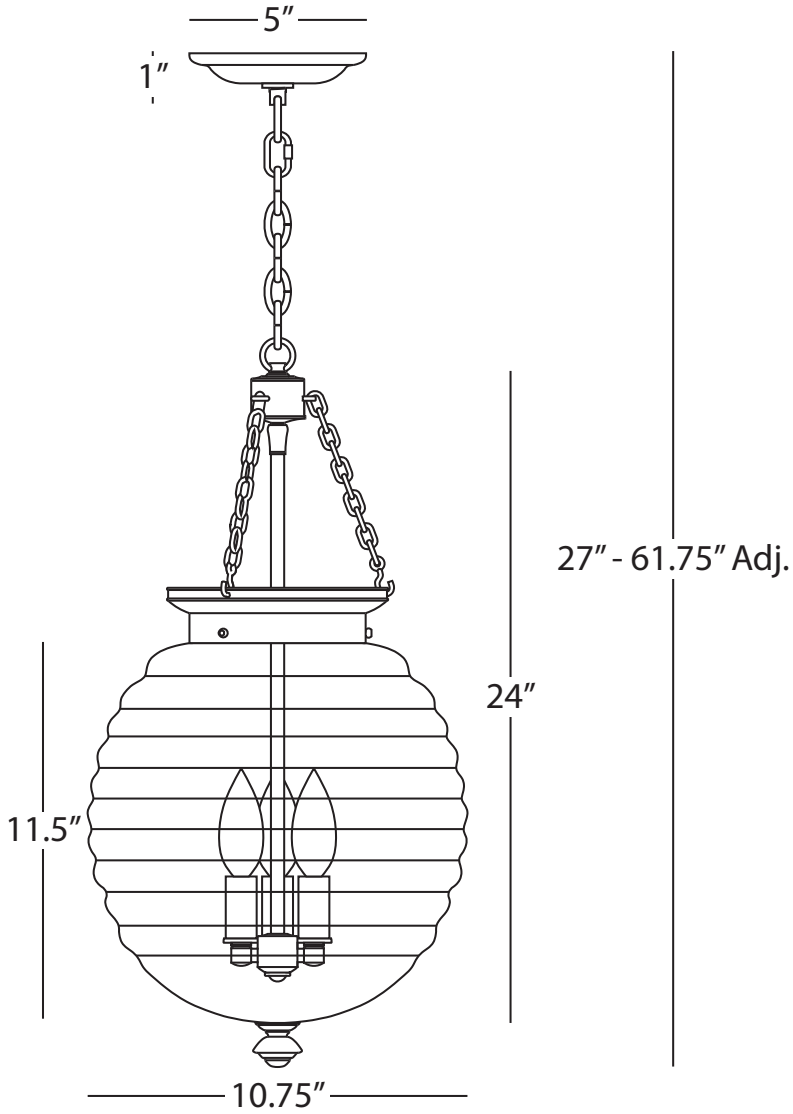

BEEHIVE

**N616**  
Pendant

- 3 - 60W Max.
- Bulb Type: B11 Torpedo
- Direct Wire Only
- Polished Nickel Finish
- Clear Glass Shade
- Susp. Hardware: 3 Ft. Chain

# | Belvedere



# Belvedere

Click photo above to watch Belvedere Table Lamp video

The Belvedere collection takes a classic urn shape and brings it to the next level with gorgeous curves and graceful tapers that create a sophisticated and timeless design.



1370



S1370

# Belvedere

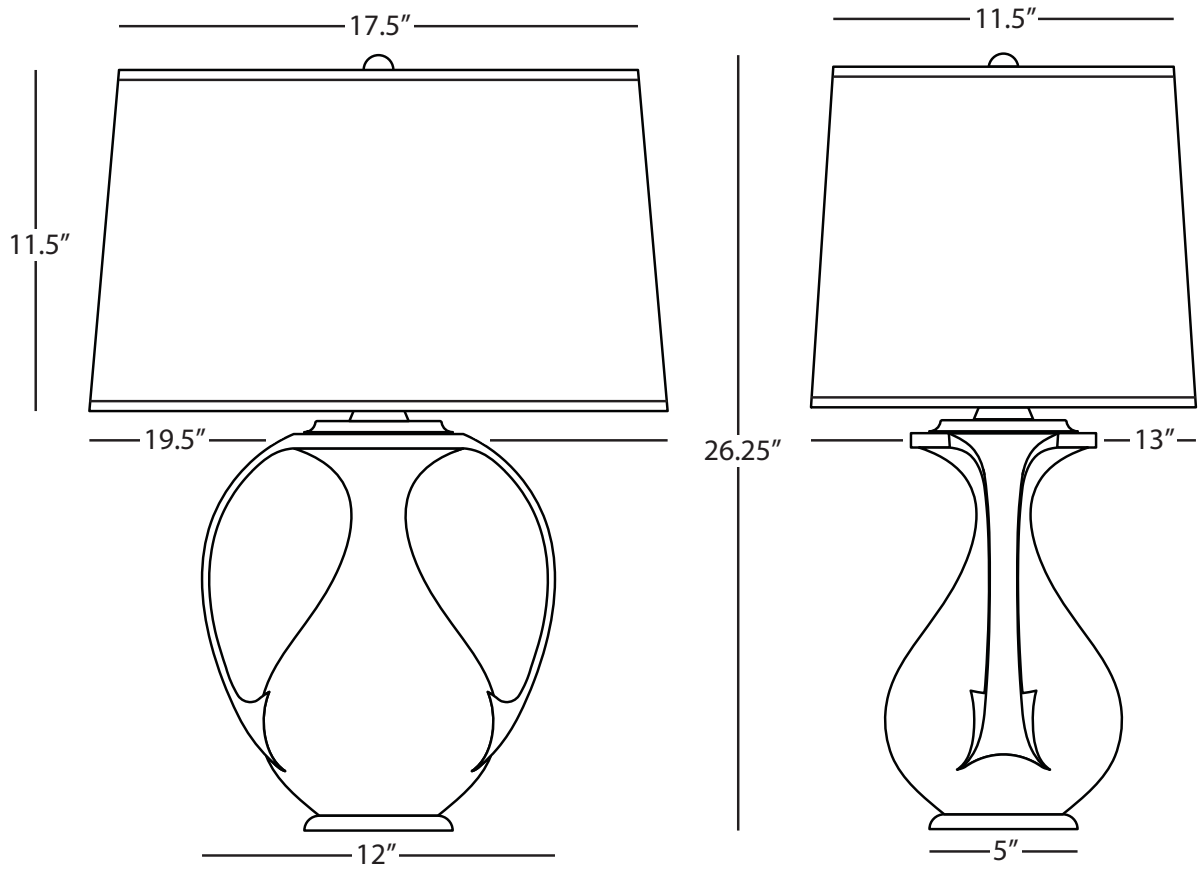

BELVEDERE

## S1370

Urn Table Lamp

1 - 150W Max.

Bulb Type: A

Switch: Full Range Dimmer

Polished Nickel Finish

Pearl Dupioni Fabric Shade

### FINISH OPTIONS:

**1370** Modern Brass

**Z1370** Deep Patina Bronze



1006



S1002



Z1001



# Bling

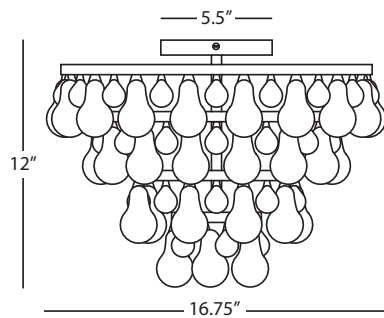

BLING

## S1002 Flush Mount

2 - 60W Max.  
Bulb Type: B, Medium Base  
Direct Wire  
Polished Nickel Finish  
Glass Drops

FINISH OPTIONS:  
**1002** Antique Brass  
**Z1002** Deep Patina Bronze

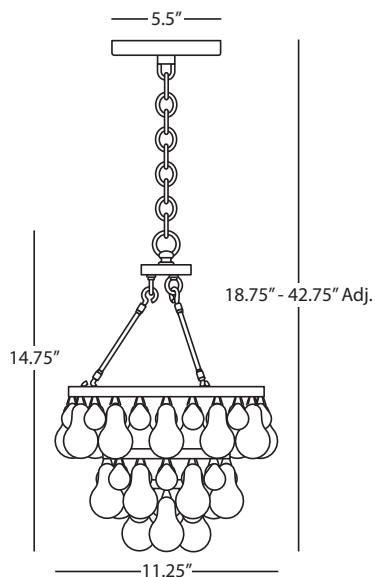

BLING

## 1006 Small Pendant

2 - 60W Max.  
Bulb Type: G16.5 Candelabra  
Direct Wire  
Antique Brass Finish  
Glass Drops  
Susp. Hardware: 3 Ft. Chain

FINISH OPTIONS:  
**S1006** Polished Nickel  
**Z1006** Deep Patina Bronze

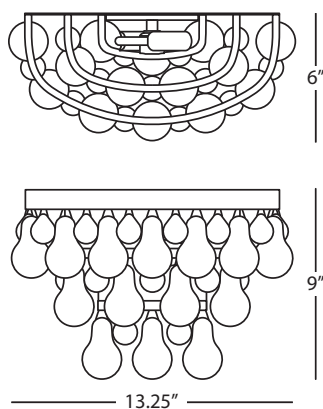

BLING

## Z1001 Wall Sconce

2 - 60W Max.  
Bulb Type: G16 Candelabra  
Direct Wire Only  
Deep Patina Bronze Finish  
Glass Drops

FINISH OPTIONS:  
**1001** Antique Brass  
**S1001** Polished Nickel



1000



1004

# Bling

BLING

## 1004

### Large Chandelier

6 - 100W Max.  
 Bulb Type: A  
 Direct Wire  
 Antique Brass Finish  
 Glass Drops  
 Susp. Hardware: 3 Ft. Chain

FINISH OPTIONS:

**S1004** Polished Nickel  
**Z1004** Deep Patina Bronze

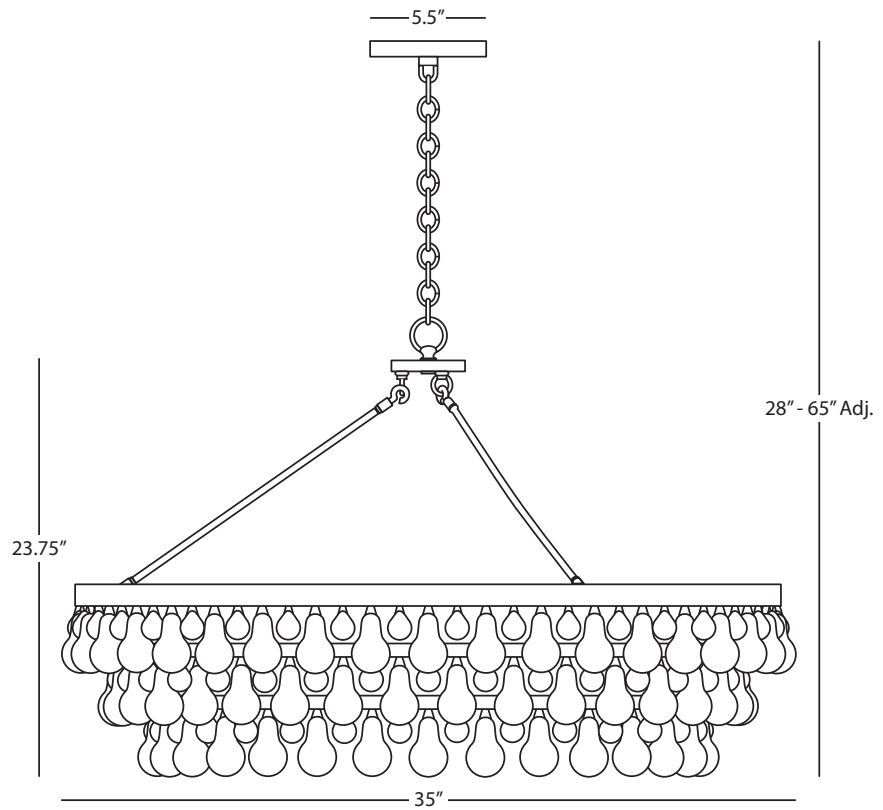

BLING

## 1000

### Chandelier w/Convertible Double Canopy\*

4 - 60W Max.  
 Bulb Type: B, Medium Base  
 Direct Wire Only  
 Antique Brass Finish  
 Glass Drops  
 Susp. Hardware: 3 Ft. Chain

FINISH OPTIONS:

**S1000** Polished Nickel  
**Z1000** Deep Patina Bronze

\*Can be converted to a semi-flush mount by mounting the center canopy directly to ceiling canopy

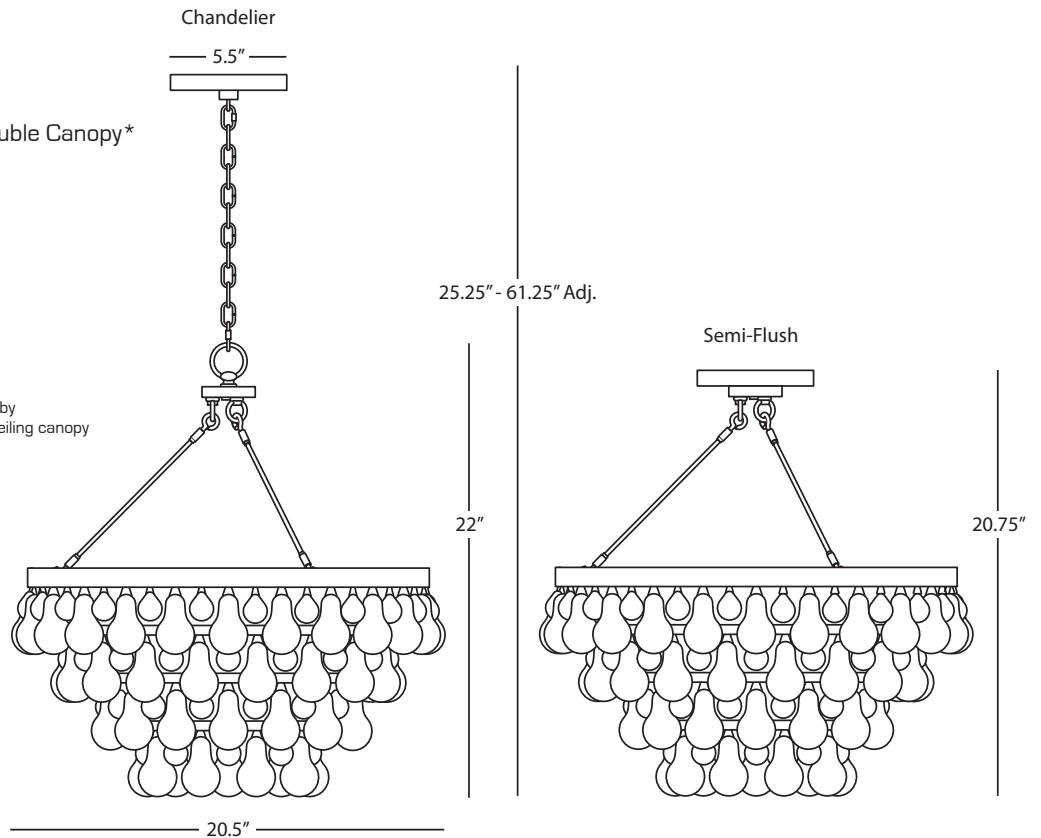



S1007



Z1008

# Bling

BLING

## S1007

### Oval Chandelier

8 - 60W Max.  
 Bulb Type: A  
 Direct Wire  
 Polished Nickel Finish  
 Glass Drops  
 Susp. Hardware: 2 pcs. 5/8" x 6"  
 & 6 pcs. 5/8" x 12" Extensions

#### FINISH OPTIONS:

**1007** Antique Brass  
**Z1007** Deep Patina Bronze

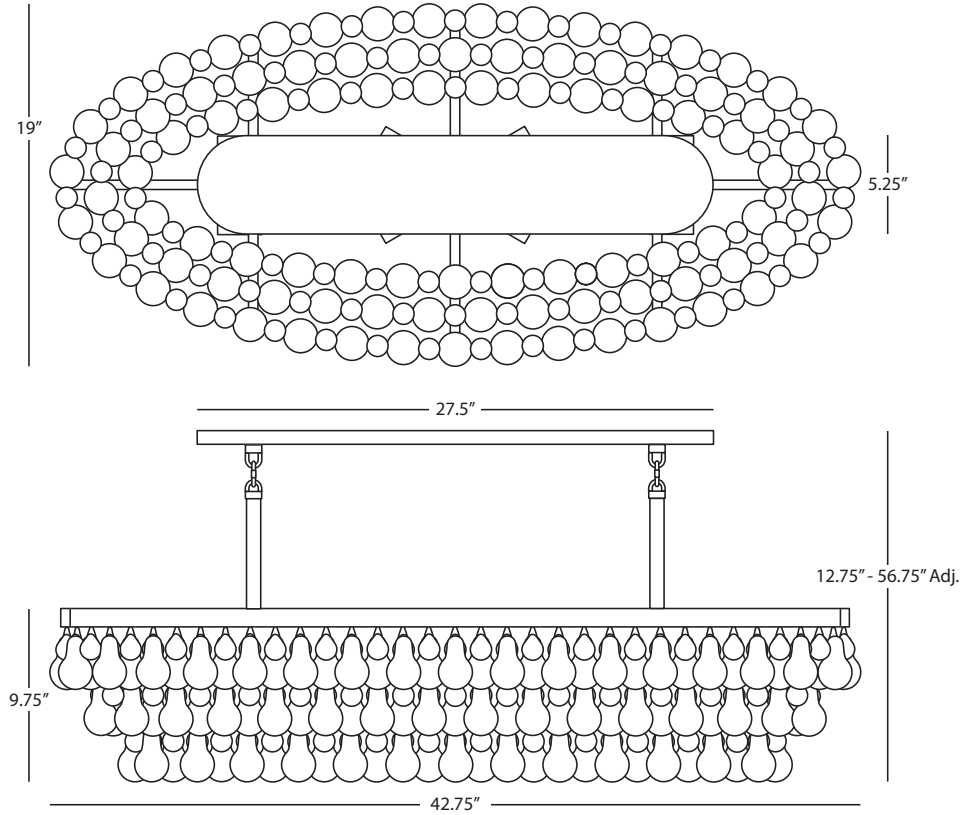

BLING

## Z1008

### Rectangular Chandelier

8 - 60W Max.  
 Bulb Type: A  
 Direct Wire  
 Deep Patina Bronze Finish  
 Glass Drops  
 Susp. Hardware: 2 pcs. 3/4" x 6"  
 & 6 pcs. 3/4" x 12" Extensions

#### FINISH OPTIONS:

**1008** Antique Brass  
**S1008** Polished Nickel

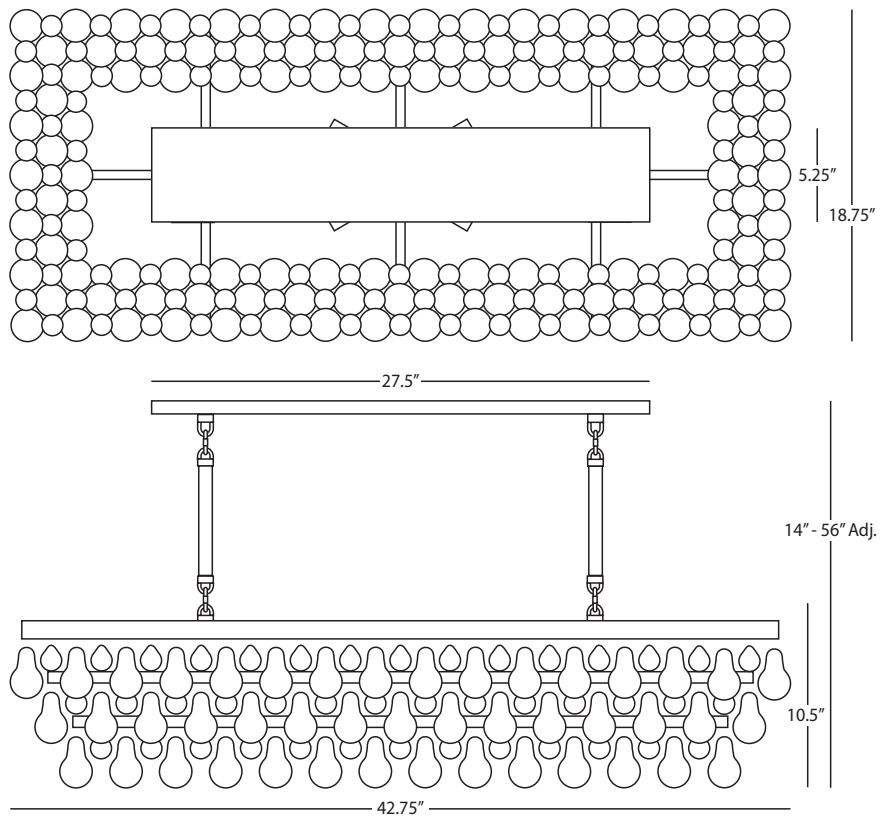



WH579



BK579

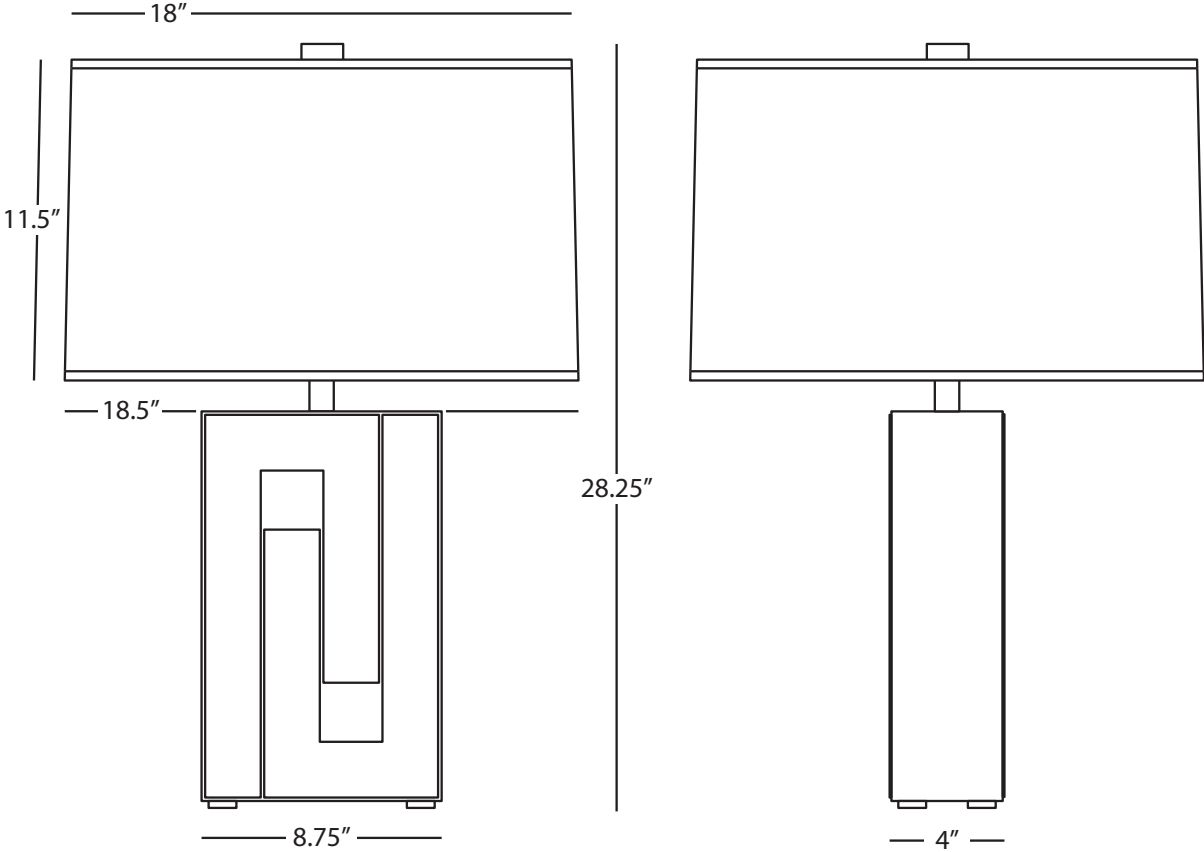

BLOX

**BK579**

Table Lamp

- 1 - 150W Max.
- Bulb Type: A
- Switch: Full Range Dimmer
- Black Enamel Finish w/  
Polished Nickel Accents
- Ascot White Fabric Shade

FINISH OPTION:  
**WH579** White Enamel



C1334



S1334



Z1334



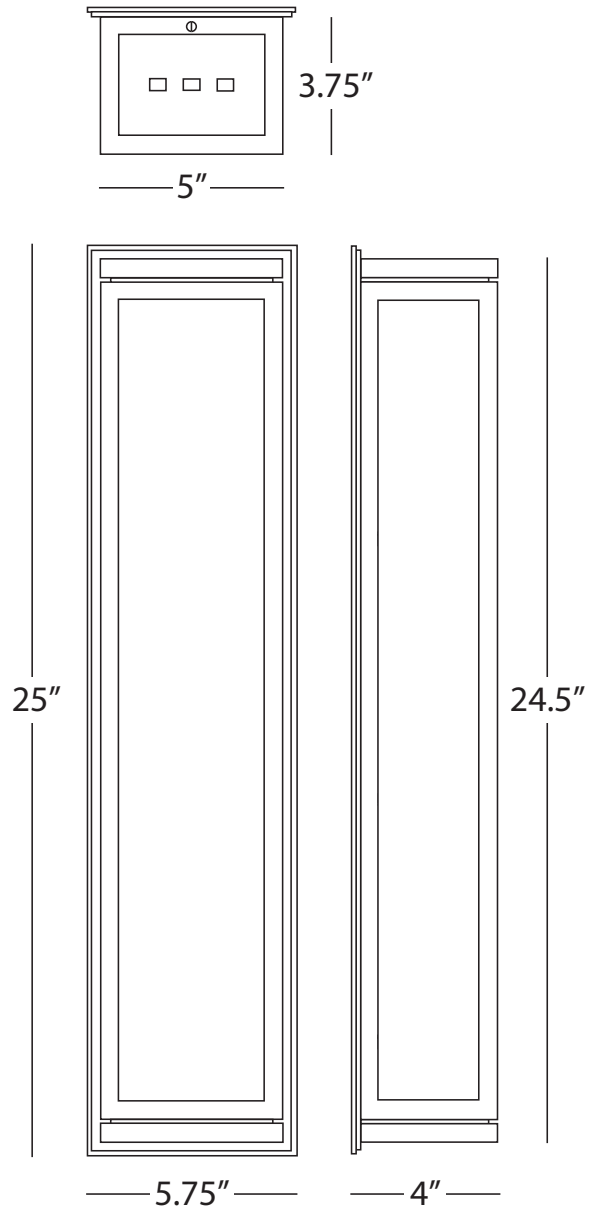

BRADLEY

### **C1334**

#### Medium Wall Sconce

3 - 60W Max.  
Bulb Type: B11 Torpedo  
Direct Wire Only  
Polished Chrome Finish  
White Glass Shade  
UL Rated for Damp Locations  
ADA Compliant

FINISH OPTIONS:

**S1334** Polished Nickel  
**Z1334** Deep Patina Bronze



279

# Braxton

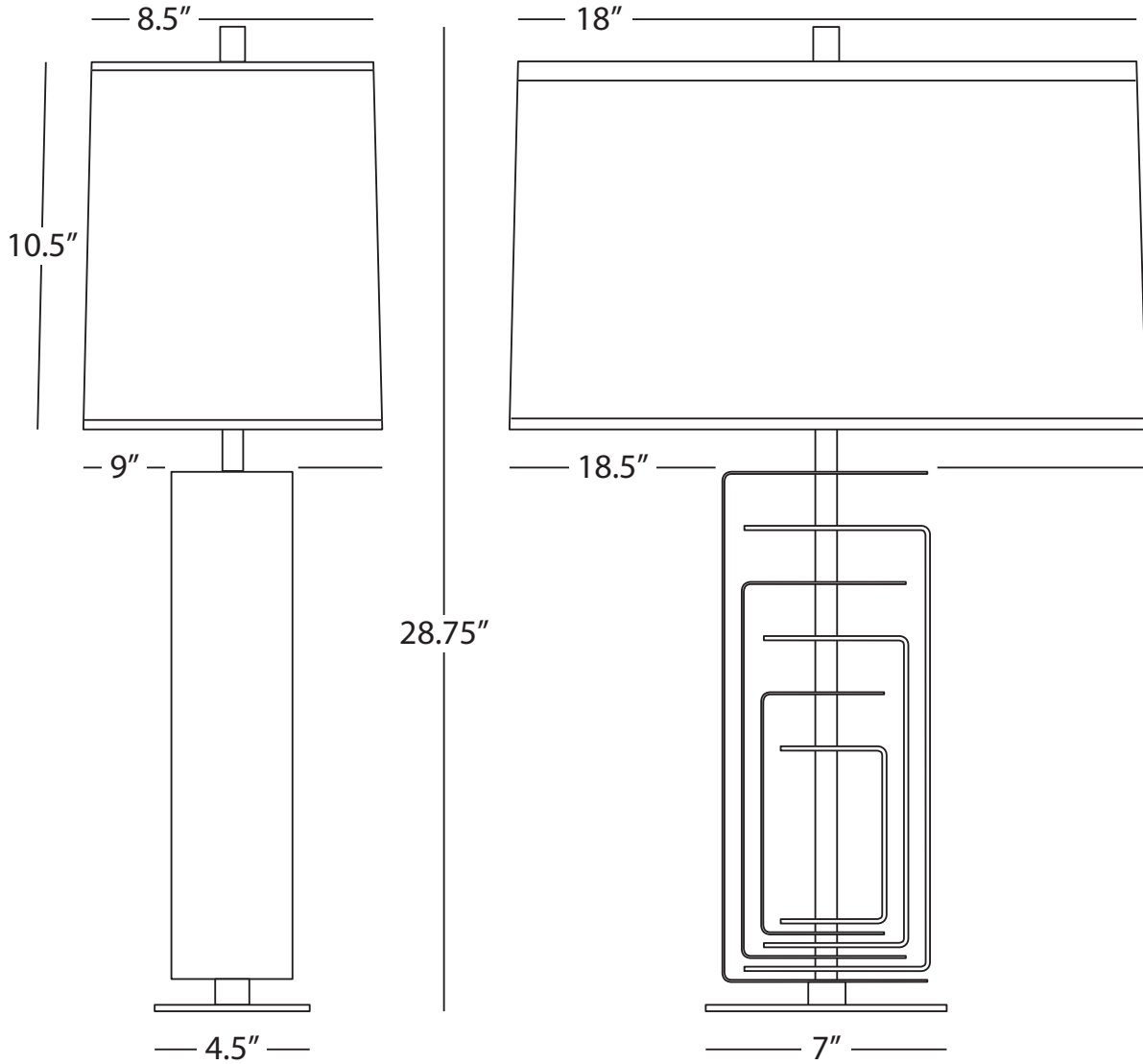

BRAXTON

**279**

Table Lamp

1 - 150W Max.  
Bulb Type: A  
Switch: Full Range Dimmer  
Modern Brass Finish  
Clear Acrylic Accents  
Rectangular Fondine Fabric Shade



S3393



3391

# Brighton

BRIGHTON

## S3393

### Ball Pendant

1 - 100W Max.  
Bulb Type: A  
Direct Wire  
Polished Nickel Finish  
Clear Halophane Glass Shade  
Susp. Hardware: 3 Ft. Chain

FINISH OPTION:

**3393** Modern Brass

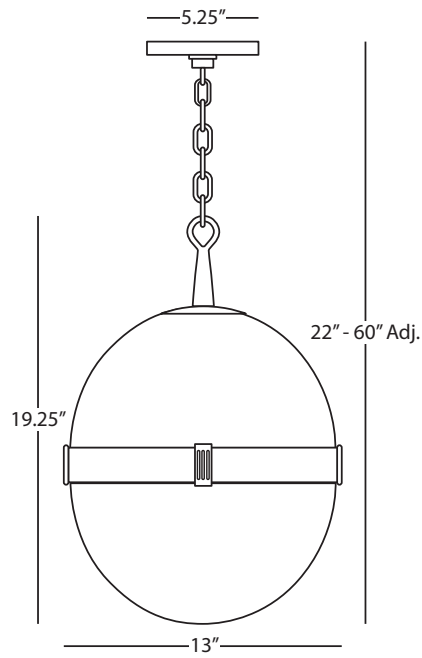

BRIGHTON

## 3391

### Pendant

1 - 150W Max.  
Bulb Type: A  
Direct Wire  
Modern Brass Finish  
Matte Black Shade Hood  
Clear Halophane Glass Diffuser  
Susp. Hardware: 3 Ft. Chain

FINISH OPTION:

**3391** Polished Nickel

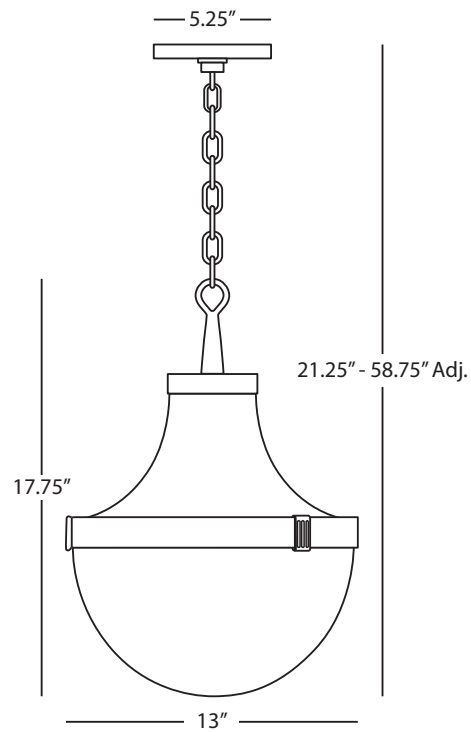



839



986



838



838X



837



837C

# Bronte

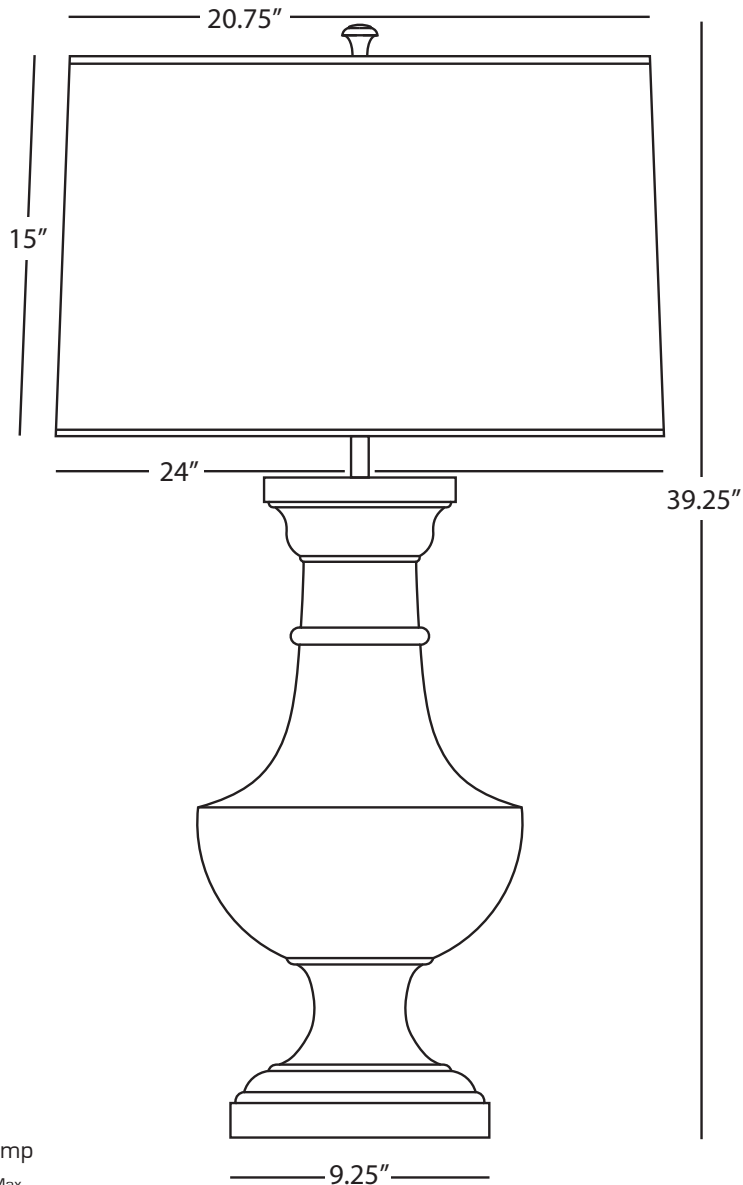

BRONTE

## **837** Table Lamp

1 - 150W Max.  
Bulb Type: A  
Switch: 3-Way  
Matte White Painted Finish over Poly Resin  
White Brussels Linen Shade

### FINISH/SHADE OPTIONS:

- 837C** Matte White Painted Finish  
Chocolate Painted Opaque Parchment Shade
- 838** Faux Limestone Painted Finish  
Oyster Linen Shade
- 838X** Faux Limestone Painted Finish  
Taupe Painted Opaque Parchment Shade w/  
Matte Silver Lining
- 839** Faux Concrete Painted Finish  
Translucent White Monte Blanc Parchment Shade
- 986** Matte Black Painted Finish  
Matte Black Painted Opaque Parchment Shade



WZ452



JV48G



WZ48R



# Bronte Al Fresco

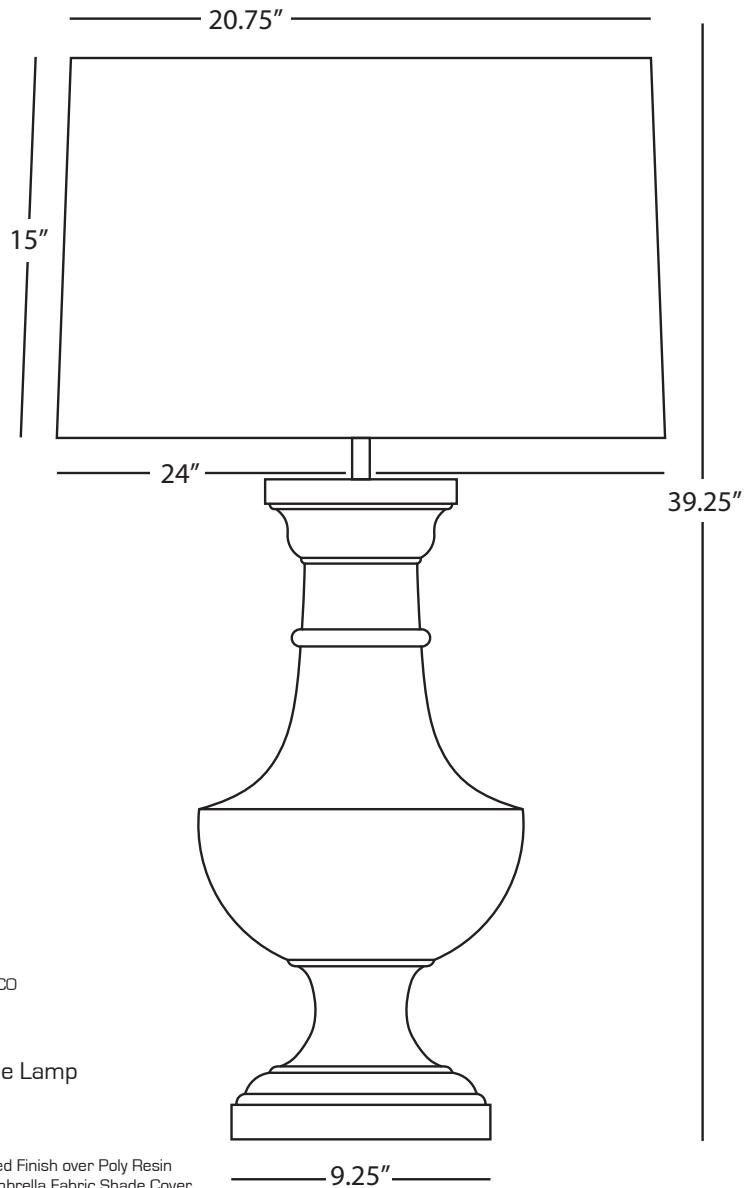

BRONTE AL FRESCO

## JV48G

Outdoor Table Lamp

1 - 100W Max.

Bulb Type: A

Switch: On-Off

Java Brown Painted Finish over Poly Resin  
Gray Jacquard Sunbrella Fabric Shade Cover  
UL Rated for Wet Locations

### FINISH/SHADE OPTIONS:

- |              |  |
|--------------|--|
| <b>JV48R</b> | Java Brown<br>Orange Jacquard Sunbrella Fabric     |
| <b>JV452</b> | Java Brown<br>White Sunbrella Fabric               |
| <b>WZ48G</b> | Weathered Zinc<br>Gray Jacquard Sunbrella Fabric   |
| <b>WZ48R</b> | Weathered Zinc<br>Orange Jacquard Sunbrella Fabric |
| <b>WZ452</b> | Weathered Zinc<br>White Sunbrella Fabric           |



1849



1847



1848



1840

# Bruno

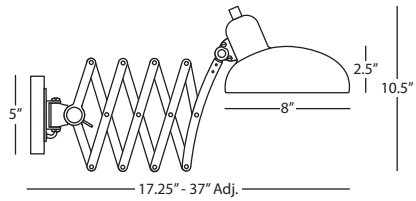

BRUNO

## 1849 Scissor Arm Wall Sconce

1 - 60W Max.  
Bulb Type: A19, Silver Tip  
Switch: On-Off  
Cord Cover/Direct Wire  
Lead Bronze Finish w/  
Ebonized Nickel Accents  
Metal Shade

Photographed with Silver Tip Bulb  
SOLD SEPARATELY  
(BULO1 See Page 225)

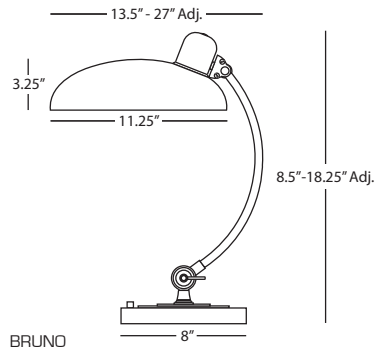

BRUNO

## 1840 Adjustable Task Table Lamp

1 - 60W Max.  
Bulb Type: G25, Silver Tip  
Switch: Hi-Lo Dimming  
Lead Bronze Finish w/ Ebonized Nickel Accents  
Lead Bronze Finished Metal Shade

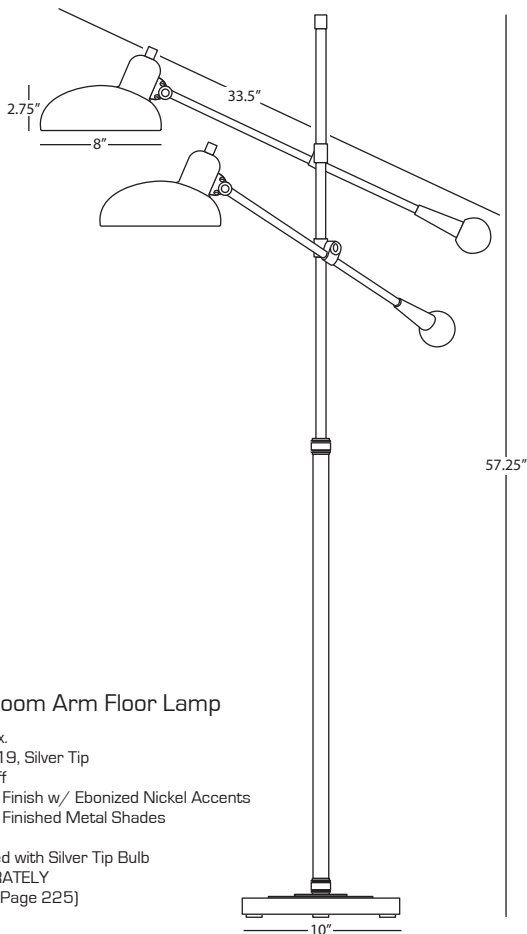

BRUNO

## 1848 Double Boom Arm Floor Lamp

2 - 60W Max.  
Bulb Type: A19, Silver Tip  
Switch: On-Off  
Lead Bronze Finish w/ Ebonized Nickel Accents  
Lead Bronze Finished Metal Shades

Photographed with Silver Tip Bulb  
SOLD SEPARATELY  
(BULO1 See Page 225)

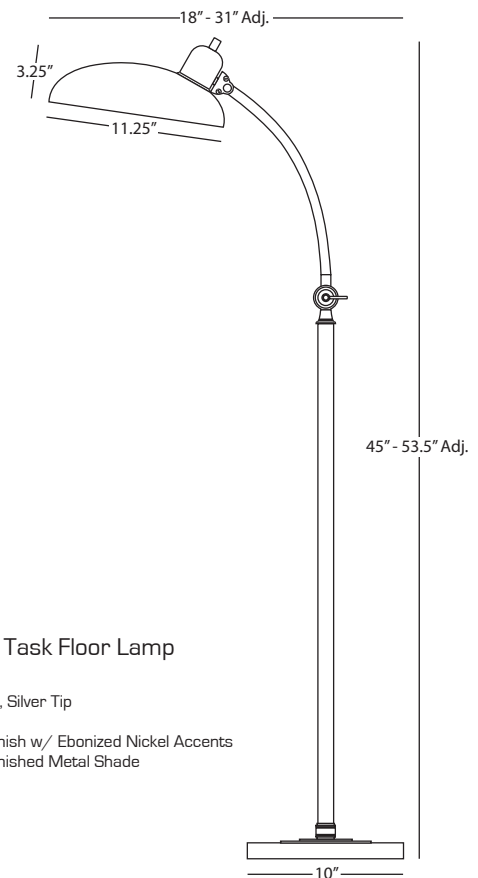

BRUNO

## 1847 Adjustable Task Floor Lamp

1 - 60W Max.  
Bulb Type: G25, Silver Tip  
Switch: On-Off  
Lead Bronze Finish w/ Ebonized Nickel Accents  
Lead Bronze Finished Metal Shade



1842X



1842W



1841



1841X

# Bruno

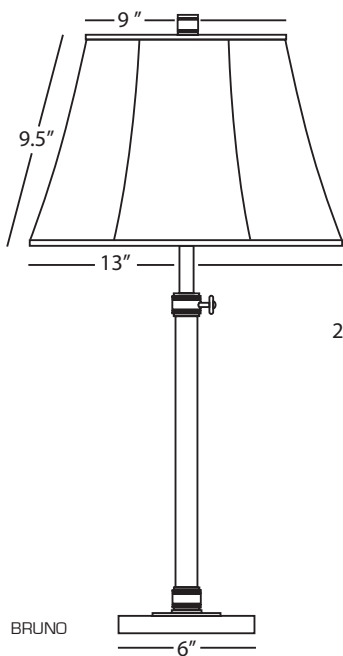

26" - 32" Adj.

BRUNO

## 1841

### Adjustable Column Table Lamp

1 - 150W Max.  
Bulb Type: A  
Switch: 3-Way  
Lead Bronze Finish w/ Ebonized  
Nickel Accents  
Gray Microfiber Fabric Empire Shade

#### SHADE OPTIONS:

**1841W** Ivory Microfiber  
**1841X** Fondine

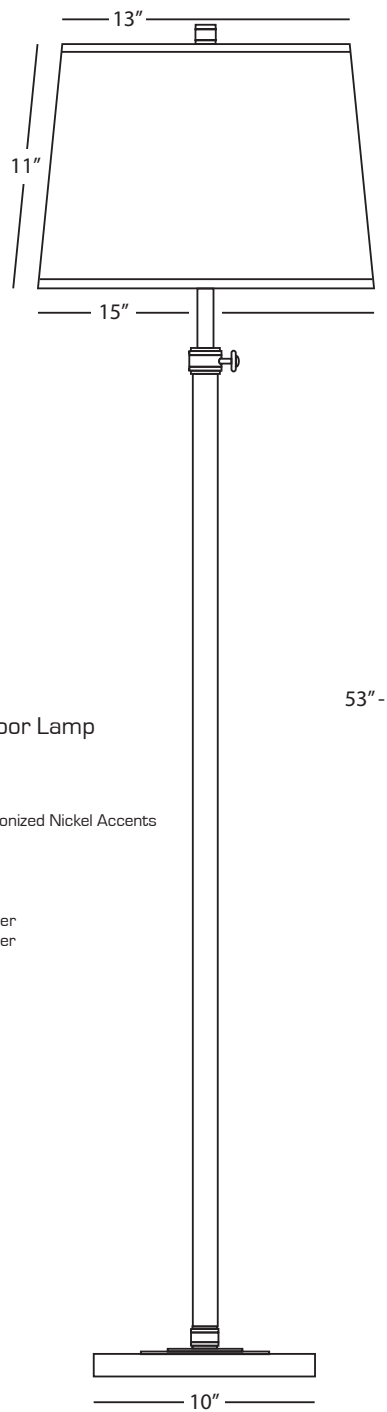

53" - 61" Adj.

BRUNO

## 1842X

### Adjustable Club Floor Lamp

1 - 150W Max.  
Bulb Type: A  
Switch: 3-Way  
Lead Bronze Finish w/ Ebonized Nickel Accents  
Fondine Fabric Shade

#### SHADE OPTIONS:

**1842** Gray Microfiber  
**1842W** Ivory Microfiber



C1319

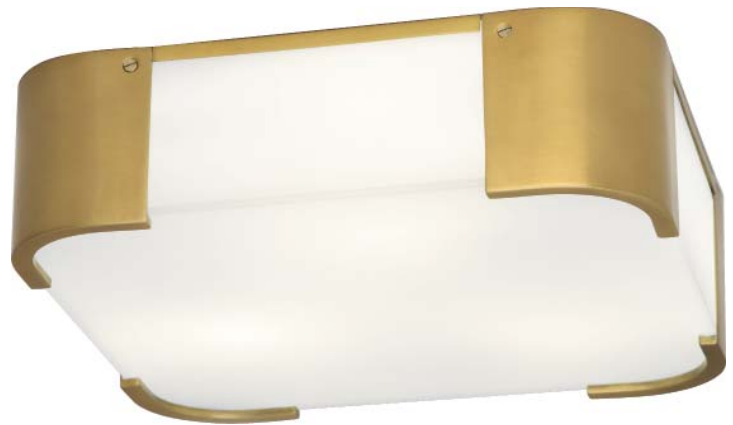

1319



Z1318



C1318



B1318

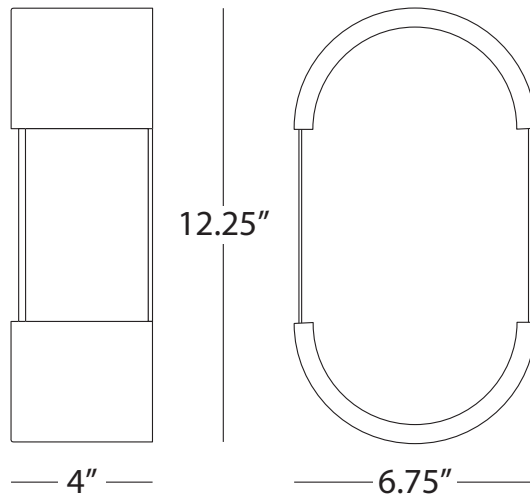

BRYCE

**B1318**  
Wall Sconce

2 - 60W Max.  
Bulb Type: B, Medium Base  
Direct Wire Only  
Brushed Nickel Finish  
White Glass Shade  
UL Rated for Damp Locations  
ADA Compliant

FINISH OPTIONS:

**1318**    Antique Brass  
**C1318**    Polished Chrome  
**Z1318**    Deep Patina Bronze

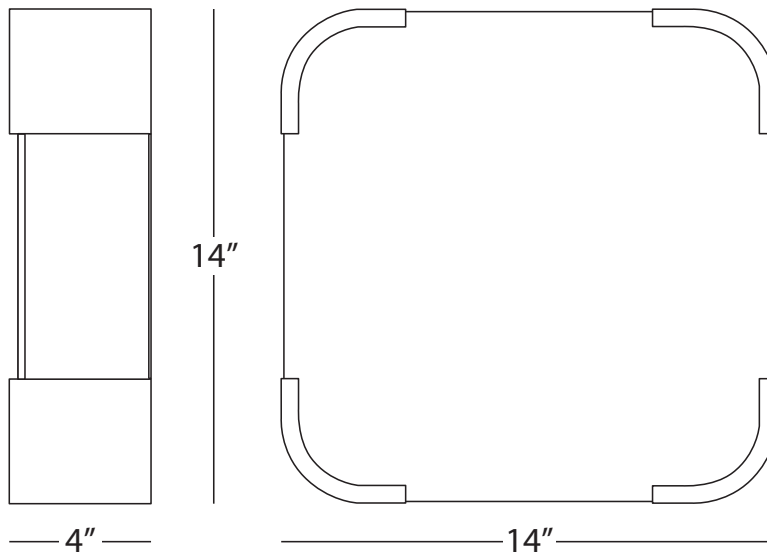

BRYCE

**1319**  
Flush Mount

3 - 60W Max.  
Bulb Type: B, Medium Base  
Direct Wire  
Antique Brass Finish  
White Glass Shade  
UL Rated for Damp Locations

FINISH OPTIONS:

**B1319**    Brushed Nickel  
**C1319**    Polished Chrome  
**Z1319**    Deep Patina Bronze



292B



S291



CAMPBELL

**S291**

**Task Table Lamp**

1 - 100W Max.  
 Bulb Type: A  
 Switch: Full Range Dimmer  
 Polished Nickel Finish  
 Oyster Linen Shade

FINISH/SHADE OPTIONS:

- 291** Modern Brass/Oyster Linen
- 291B** Modern Brass/Anna Black Fabric w/ Gold Lining
- S291B** Polished Nickel/Anna Black Fabric w/ Silver Lining

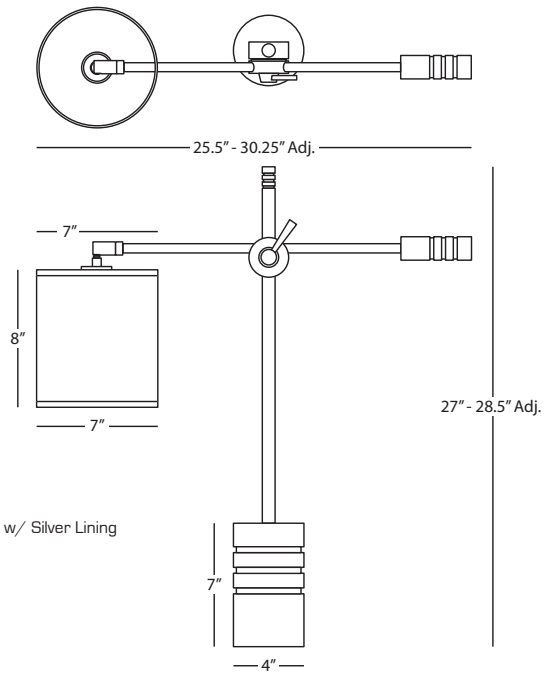

CAMPBELL

**292B**

**Task Floor Lamp**

1 - 100W Max.  
 Bulb Type: A  
 Switch: Full Range Dimmer  
 Modern Brass Finish  
 Anna Black Fabric Shade w/ Gold Lining

FINISH/SHADE OPTIONS:

- 292** Modern Brass/Oyster Linen
- S292** Polished Nickel/Oyster Linen
- S292B** Polished Nickel/Anna Black Fabric w/ Silver Lining

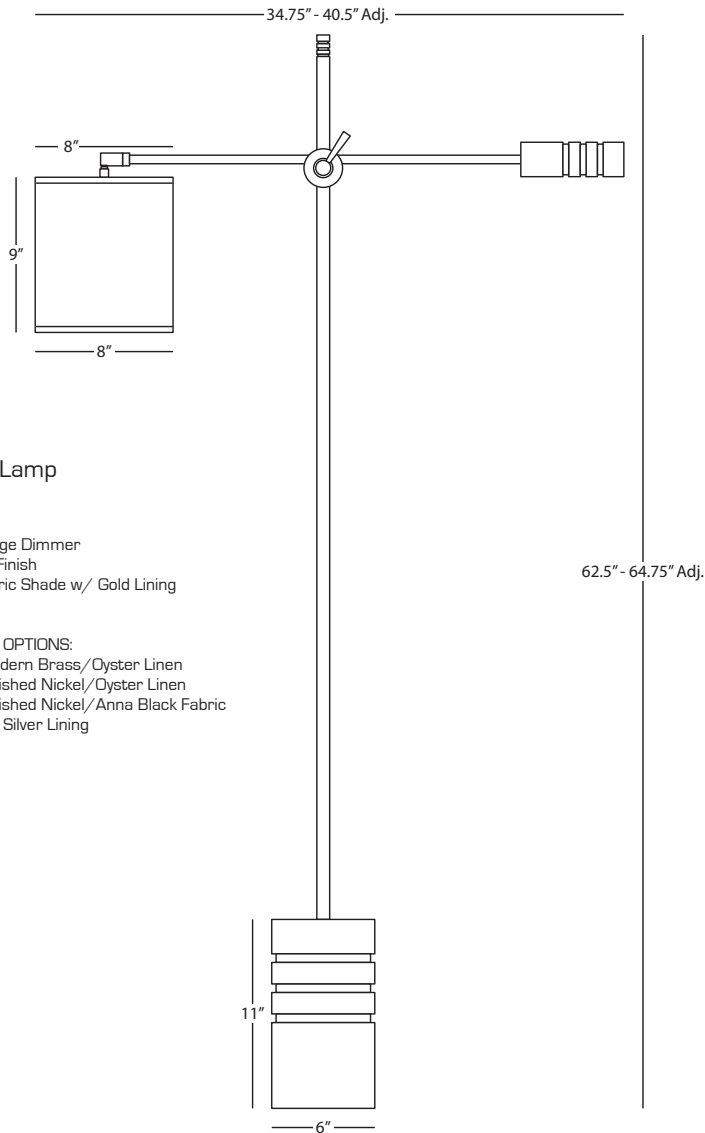



MOB15



MLY15



MCR15



MCL15



MCF16



MST16



MMB16

# Cecilia

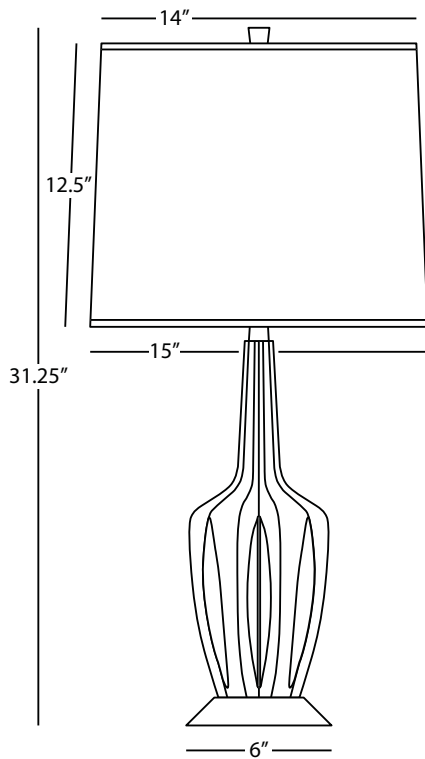

CECILIA

## MCL15

### Accent Lamp

1 - 150W Max.  
 Bulb Type: A  
 Switch: Hi-Lo Dimming  
 Matte Celadon Glazed Ceramic  
 Walnut Finished Wood Base  
 Oyster Linen Shade

COLOR OPTIONS:

**MCF15** Matte Coffee  
**MCR15** Matte Ash  
**MLY15** Matte Lily  
**MMB15** Matte Midnight Blue  
**MOB15** Matte Steel Blue  
**MST15** Matte Smoky Taupe

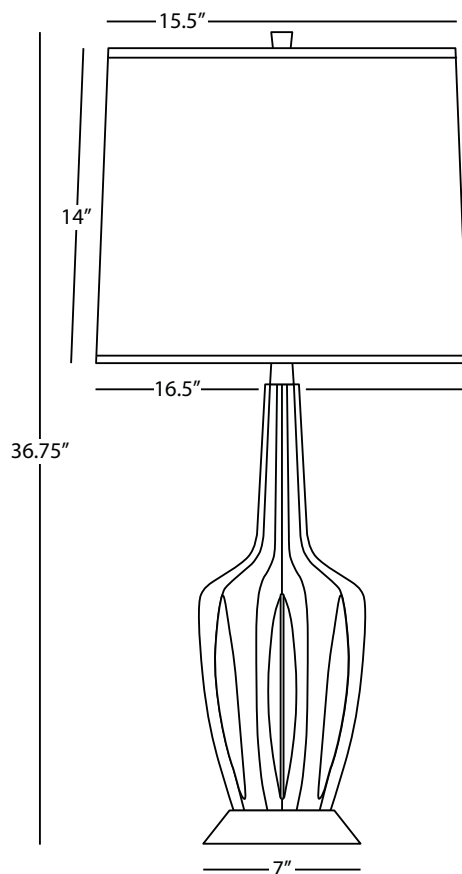

CECILIA

## MCF16

### Table Lamp

1 - 150W Max.  
 Bulb Type: A  
 Switch: Hi-Lo Dimming  
 Matte Coffee Glazed Ceramic  
 Walnut Finished Wood Base  
 Oyster Linen Shade

COLOR OPTIONS:

**MCL16** Matte Celadon  
**MCR16** Matte Ash  
**MLY16** Matte Lily  
**MMB16** Matte Midnight Blue  
**MOB16** Matte Steel Blue  
**MST16** Matte Smoky Taupe



S388

388

Z388

# Cedric

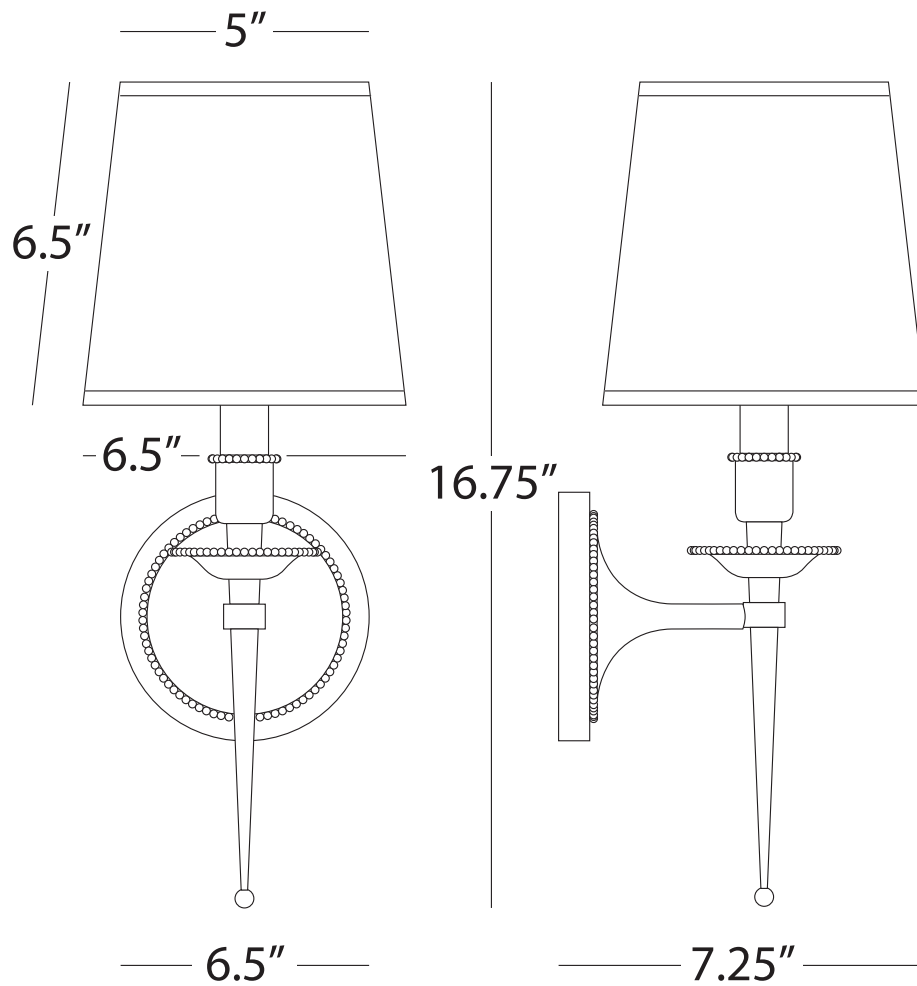

CEDRIC

**388**

Wall Sconce

1 - 60W Max.  
Bulb Type: B, Candelabra Base  
Switch: On-Off Line Switch  
Warm Brass Finish  
Ascot White Fabric Shade

FINISH OPTIONS:

**S388** Polished Nickel  
**Z388** Deep Patina Bronze



1215



S1215

# Celeste

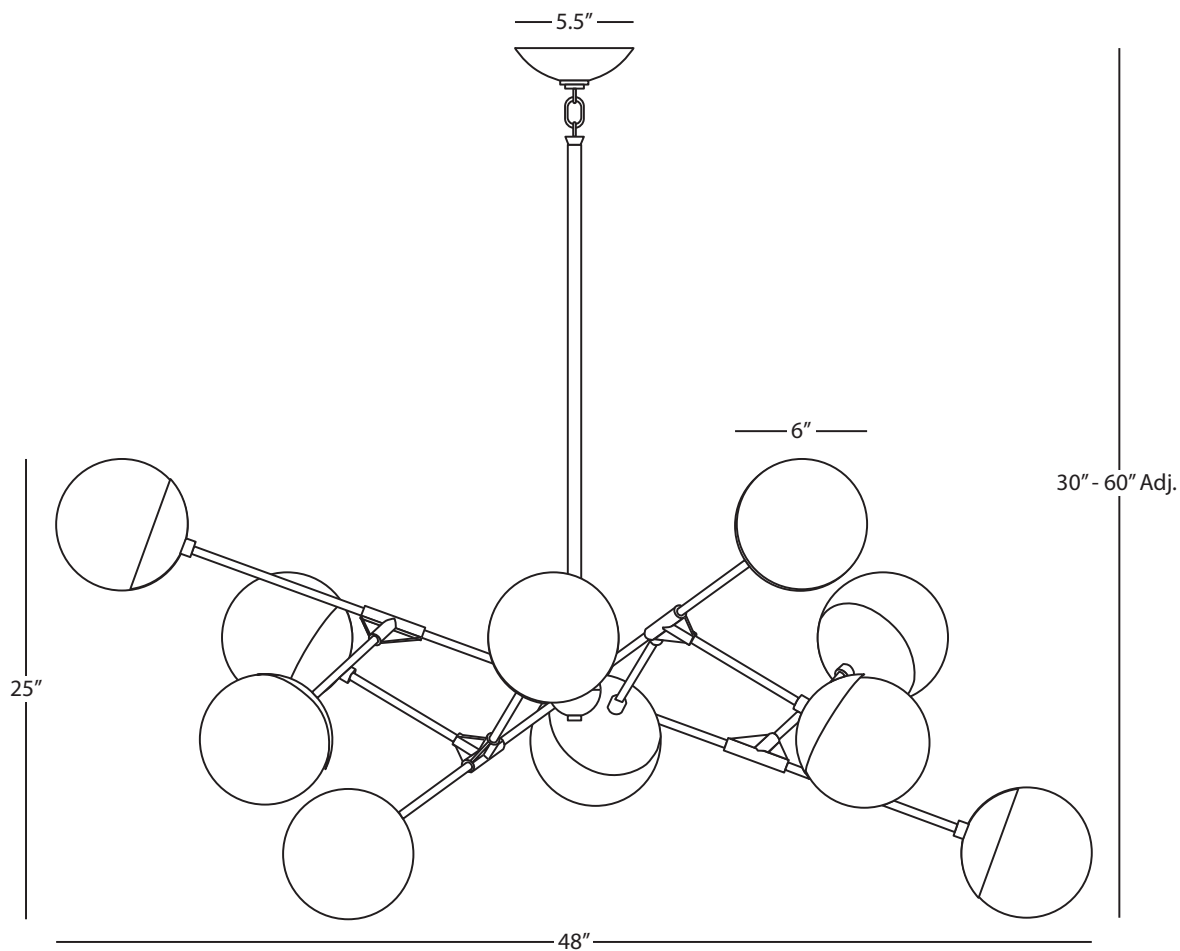

CELESTE

## 1215 Chandelier

12 - 40W Max.  
Bulb Type: A15  
Direct Wire  
Modern Brass Finish  
Clear Glass Globe Shades  
Susp. Hardware: 1 pc. 5/8" x 6" & 3 pcs.  
5/8" x 12" Extensions

FINISH OPTION:  
**S1215** Polished Nickel

Celine





# Celine

---

[Click photo above to watch Celine Table Lamp Video](#)

The name Celine means “heavenly” and this beautiful collection speaks the language of the moon—serene and enchanting. With a clear crystal ball and contrasting deep patina bronze accents, Celine makes a space feel polished and elegant.

---

Celine



# Celine

---

[Click photo above to watch Celine Accent Lamp Video](#)

The name Celine means “heavenly” and this beautiful collection speaks the language of the moon—serene and enchanting. With a clear crystal ball and contrasting deep patina bronze accents, Celine makes a space feel polished and elegant.

---



1013



1014

# Celine

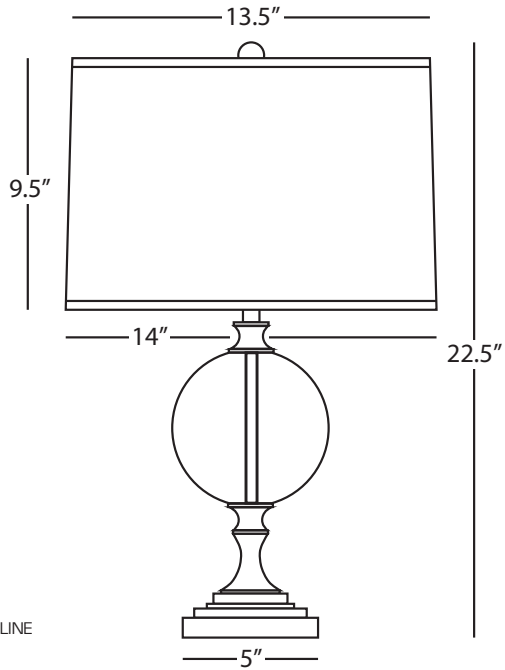

CELINE

## 1013 Accent Lamp

1 - 150W Max.  
Bulb Type: A  
Switch: Full Range Dimmer  
Deep Patina Bronze Finish w/  
Clear Crystal Ball  
Painted Bronze Parchment Shade w/  
Bright Silver Lining

SHADE OPTION:  
**1013X** Pearl Dupioni

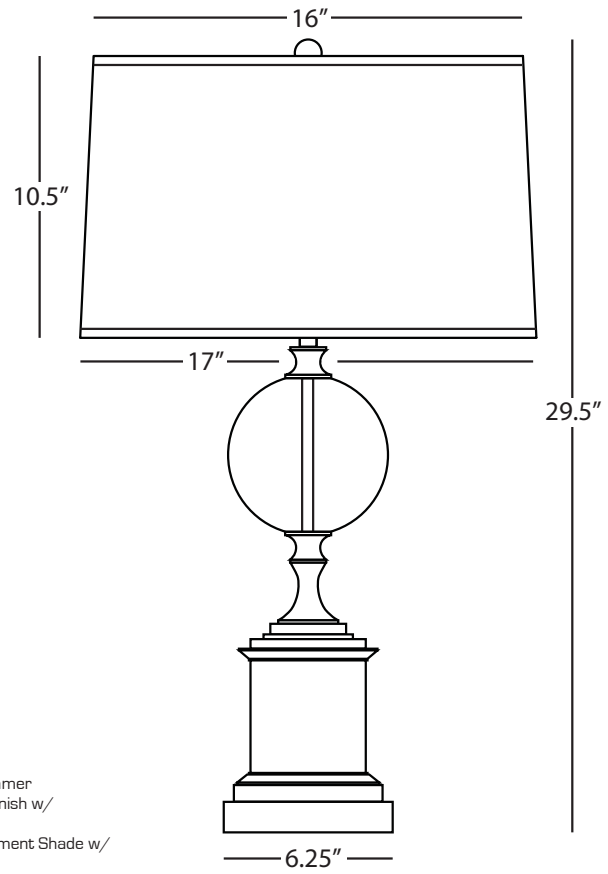

CELINE

## 1014 Table Lamp

1 - 150W Max.  
Bulb Type: A  
Switch: Full Range Dimmer  
Deep Patina Bronze Finish w/  
Clear Crystal Ball  
Painted Bronze Parchment Shade w/  
Bright Silver Lining

SHADE OPTION:  
**1014X** Pearl Dupioni



1988



1985



D1985



S1987



D1986

# Chase

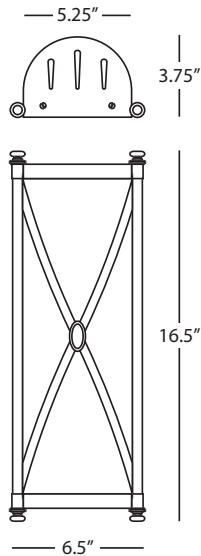

CHASE

## D1986 Small Wall Sconce

2 - 40W Max.  
Bulb Type: B, Medium Base  
Direct Wire Only  
Dark Antique Nickel Finish  
Frosted White Cased Glass Shade  
UL Rated for Damp Locations  
ADA Compliant  
\*Can Be Mounted Horizontally or Vertically\*

FINISH OPTIONS:

**1986** Antique Brass  
**S1986** Polished Nickel  
**Z1986** Deep Patina Bronze

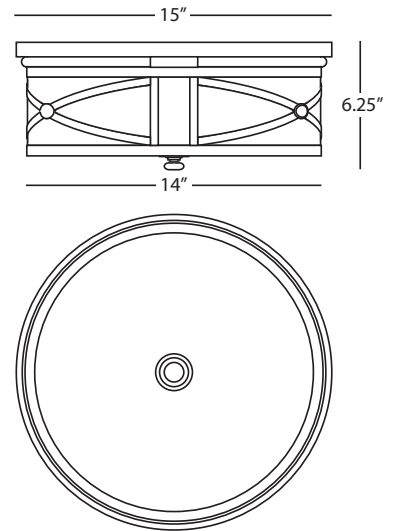

CHASE

## 1985 Flush Mount

3 - 60W Max.  
Bulb Type: A  
Direct Wire Only  
Antique Brass Finish  
Frosted White Glass Shade

FINISH OPTIONS:

**D1985** Dark Antique Nickel  
**S1985** Polished Nickel  
**Z1985** Deep Patina Bronze

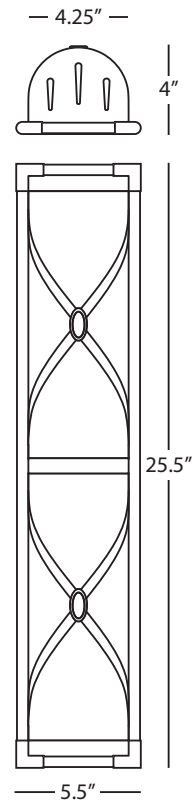

CHASE

## S1987 Medium Wall Sconce

4 - 60W Max.  
Bulb Type: B, Medium Base  
Direct Wire Only  
Polished Nickel Finish  
Frosted White Cased Glass Shade  
UL Rated for Damp Locations  
ADA Compliant  
\*Can Be Mounted Horizontally or Vertically\*

FINISH OPTIONS:

**1987** Antique Brass  
**D1987** Dark Antique Nickel  
**Z1987** Deep Patina Bronze

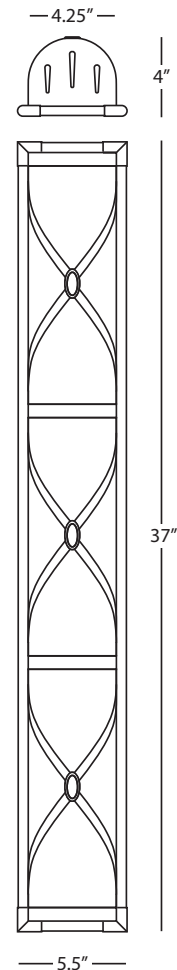

CHASE

## 1988 Large Wall Sconce

6 - 60W Max.  
Bulb Type: B, Medium Base  
Direct Wire Only  
Antique Brass Finish  
Frosted White Cased Glass Shade  
UL Rated for Damp Locations  
ADA Compliant  
\*Can Be Mounted Horizontally or Vertically\*

FINISH OPTIONS:

**D1988** Dark Antique Nickel  
**S1988** Polished Nickel

# Cinch





# Cinch

[Click photo above to watch Cinch Table Lamp video](#)

Cinch's design is simple but dramatic. An exaggerated hourglass shape and matte black finish make this collection a stylish choice for modern spaces.



1250



1251



1252

# Cinch

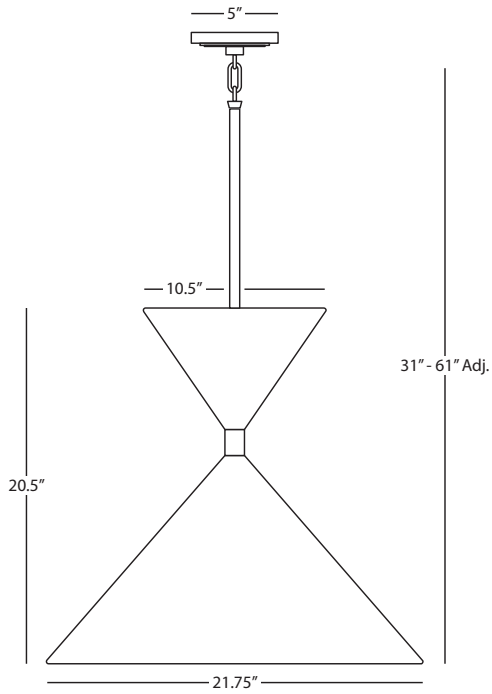

CINCH

## 1251 Pendant

1 - 60W Max.  
Bulb Type: A  
Direct Wire  
Matte Black Painted Finish  
Matching Metal Shade w/ White Interior  
Susp. Hardware: 1 pc. 5/8" x 6" & 3 pcs.  
5/8" x 12" Extensions

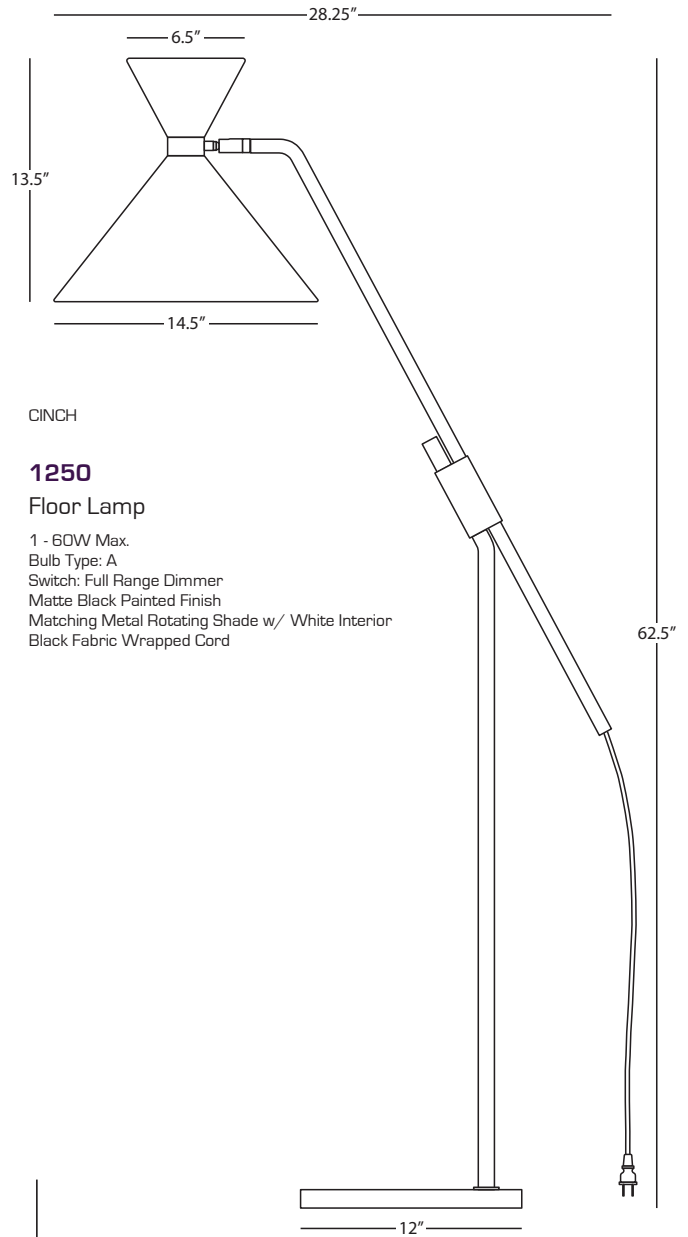

CINCH

## 1250 Floor Lamp

1 - 60W Max.  
Bulb Type: A  
Switch: Full Range Dimmer  
Matte Black Painted Finish  
Matching Metal Rotating Shade w/ White Interior  
Black Fabric Wrapped Cord

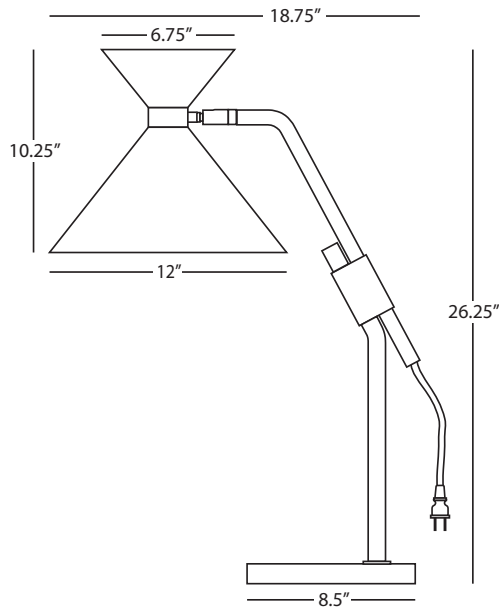

CINCH

## 1252 Table Lamp

1 - 60W Max.  
Bulb Type: A  
Switch: Full Range Dimmer  
Matte Black Painted Finish  
Matching Metal Shade w/ White Interior  
Black Fabric Wrapped Cord



S3337



S3336

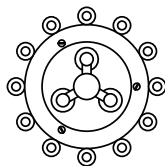
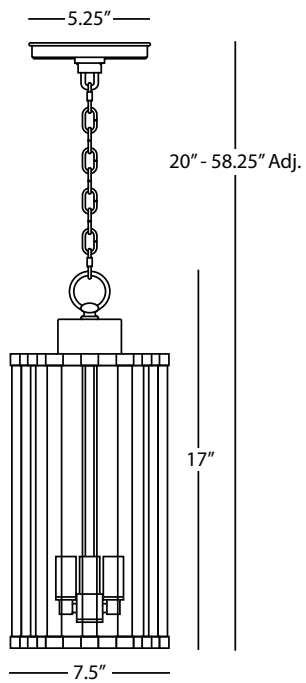

COLE

**S3336**  
Small Narrow Pendant

3 - 60W Max.  
Bulb Type: B, Candelabra  
Direct Wire Only  
Clear Glass Rods w/ Clear Inner Glass Shade  
Polished Nickel Finished Accents  
Susp. Hardware: 3 Ft. Chain

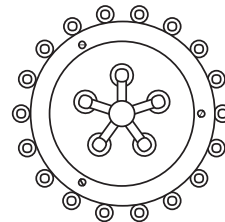
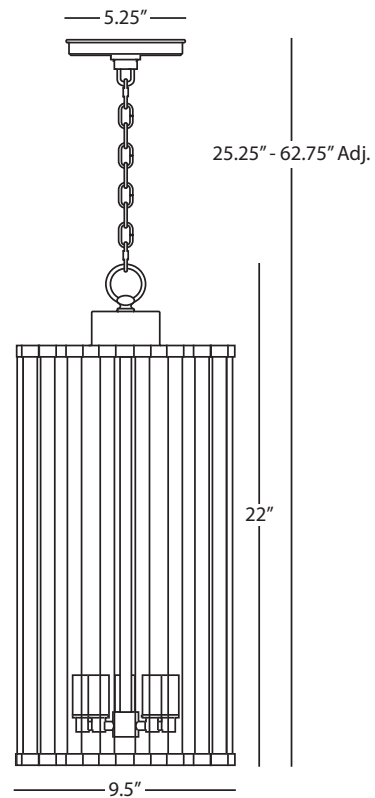

COLE

**S3337**  
Large Narrow Pendant

5 - 60W Max.  
Bulb Type: B, Candelabra  
Direct Wire Only  
Clear Glass Rods w/ Clear Inner Glass Shade  
Polished Nickel Finished Accents  
Susp. Hardware: 3 Ft. Chain



1245

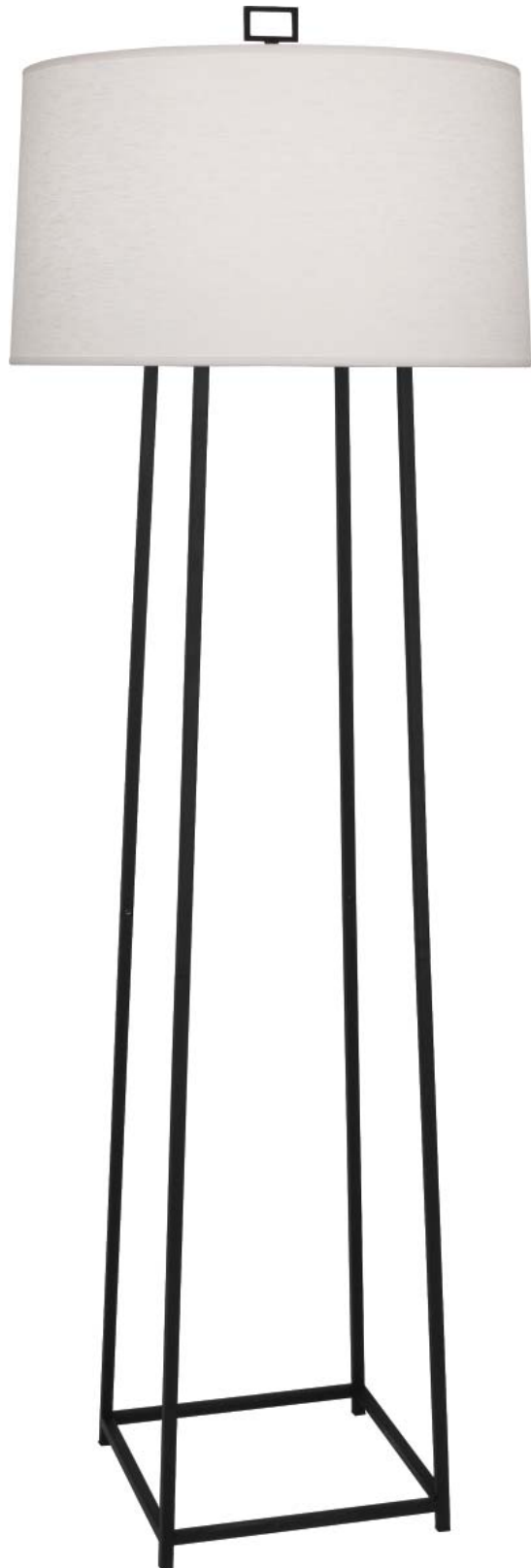

1246

# Cooper

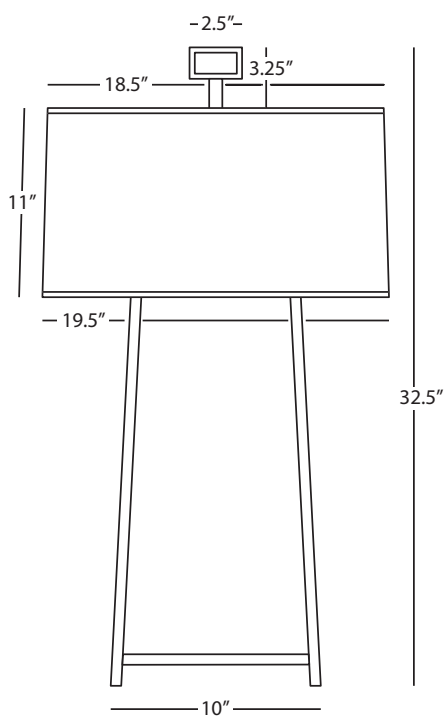

COOPER

## 1245

### Table Lamp

1 - 150W Max.  
Bulb Type: A  
Switch: Full Range Dimmer  
Wrought Iron Finish  
Oyster Linen Shade

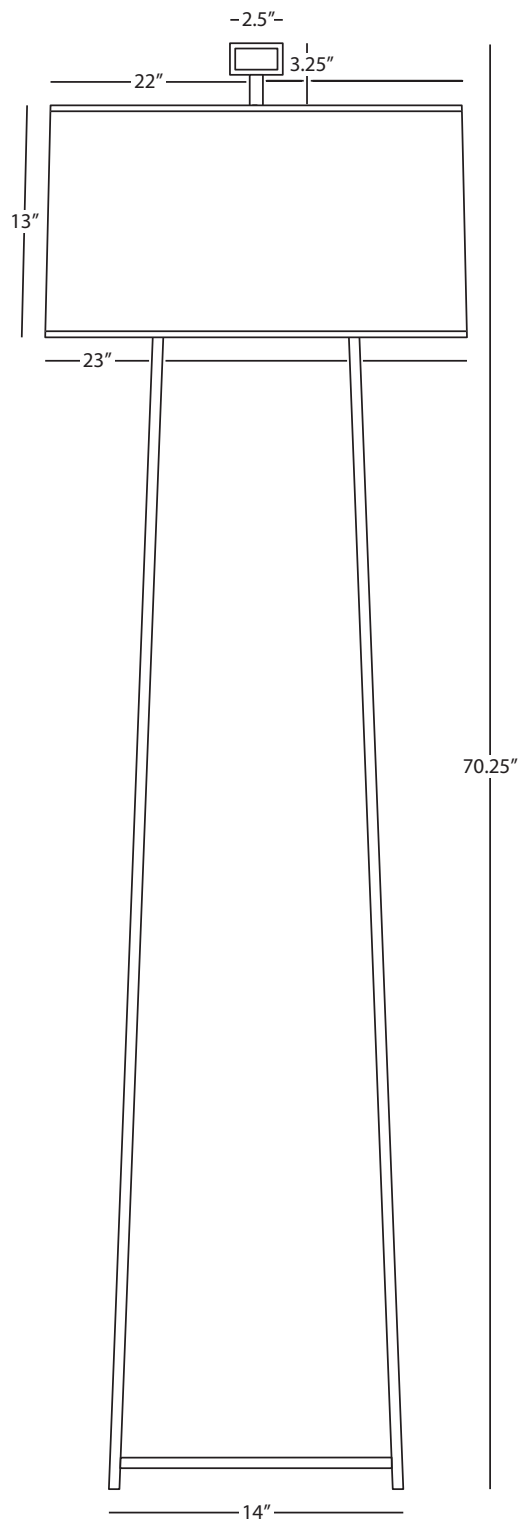

COOPER

## 1246

### Floor Lamp

1 - 150W Max.  
Bulb Type: A  
Switch: Full Range Dimmer  
Wrought Iron Finish  
Oyster Linen Shade



1016



1018



S1015



S1017



# Cosmos

COSMOS

## 1018 Chandelier

7 - 60W Max.  
Bulb Type: B, Candelabra Base  
1 - 5W Max.  
Bulb Type: GU10 LED MR16  
Direct Wire  
Deep Patina Bronze Finish w/  
Warm Brass Accents  
Oyster Linen Fabric Shades  
Frosted Glass Diffuser  
Susp. Hardware: 3 pcs. 1/2" x 6" &  
9 pcs. 1/2" x 12" Extensions

FINISH OPTION:  
**S1018** Antique Silver Accents

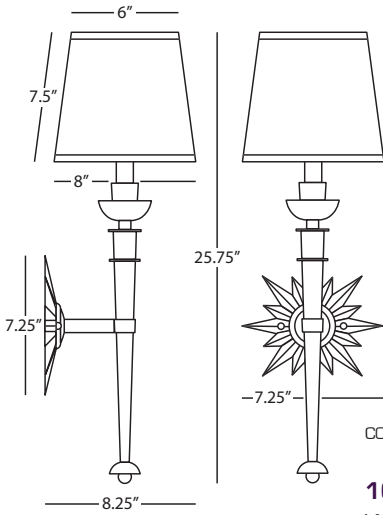
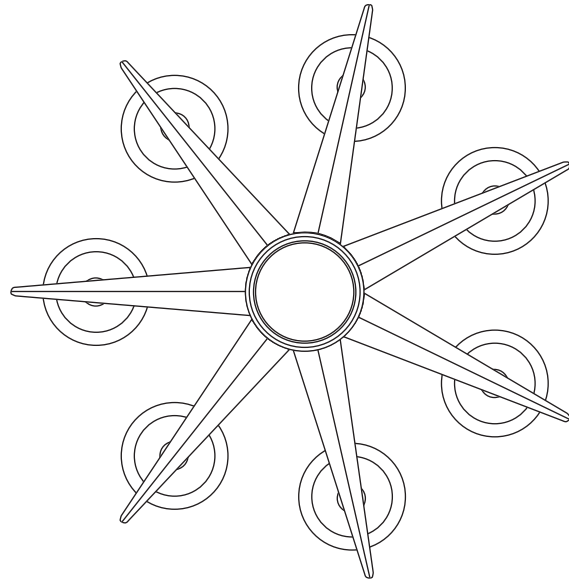

COSMOS

## 1016 Wall Sconce

1 - 60W Max.  
Bulb Type: B, Candelabra  
Direct Wire Only  
Deep Patina Bronze Finish w/  
Warm Brass Accents  
Oyster Linen Fabric Shade

FINISH OPTION:  
**S1016** Antique Silver Accents

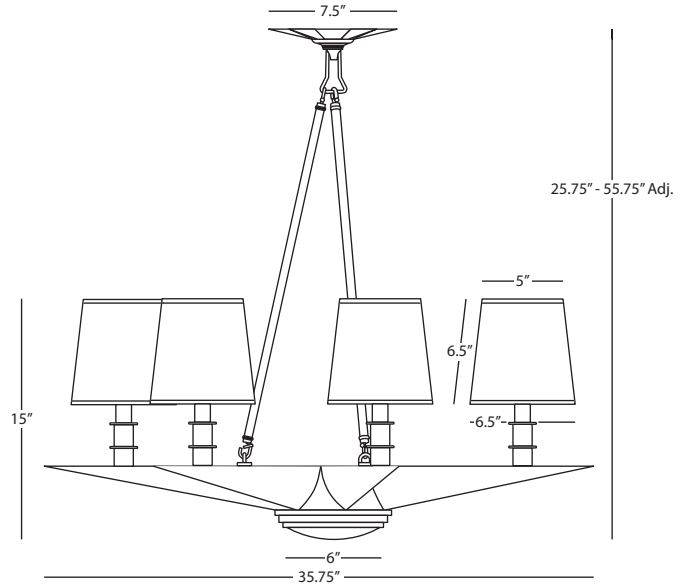

COSMOS

## S1015 Table Lamp

1 - 150W Max.  
Bulb Type: A  
Switch: Full Range Dimmer  
Deep Patina Bronze Finish w/  
Antique Silver Accents  
Oyster Linen Fabric Shade

FINISH OPTION:  
**1015** Warm Brass Accents

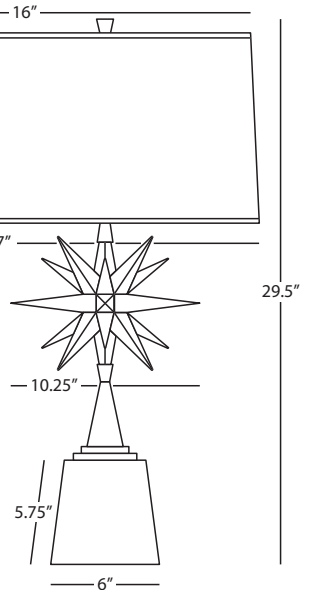

COSMOS

## S1017 Flush Mount

2 - 60W Max.  
Bulb Type: B, Candelabra Base  
Direct Wire  
Deep Patina Bronze Finish w/  
Antique Silver Accents  
Frosted Glass Diffuser

FINISH OPTION:  
**1017** Warm Brass Accents

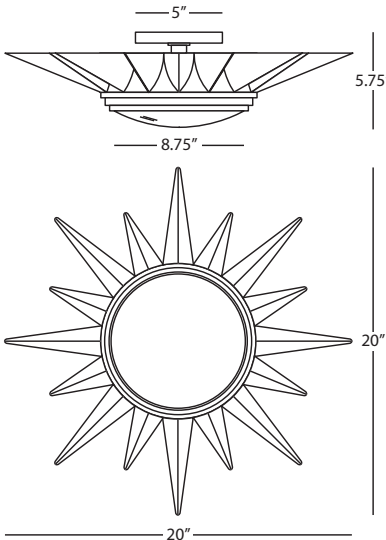



625



S625

# Cristallo

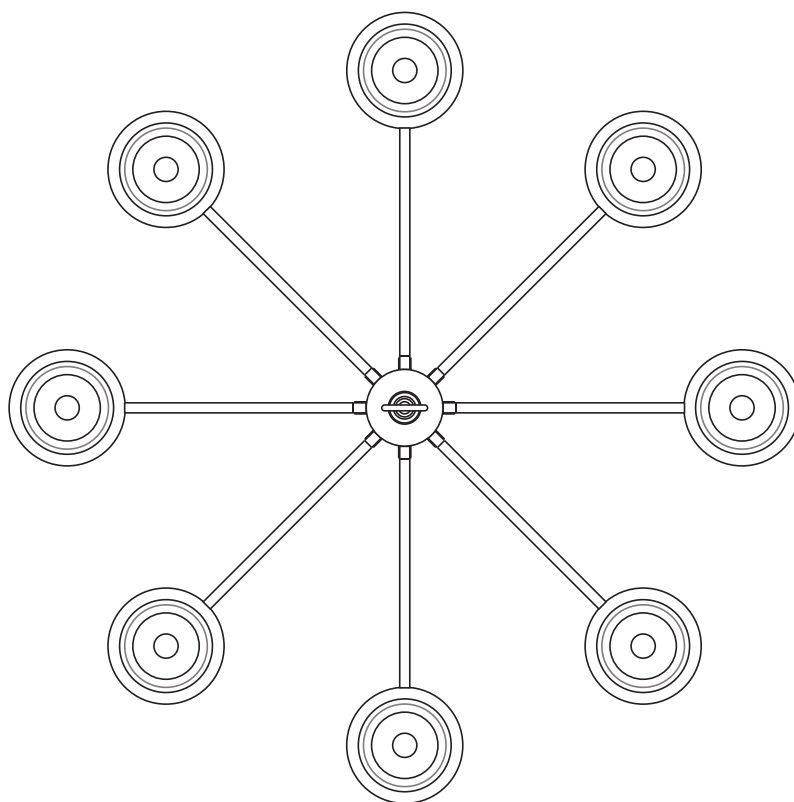

CRISTALLO

## 625

### Chandelier

8 - 60W Max.  
Bulb Type: B, Candelabra  
Direct Wire  
Modern Brass Finish w/  
Smoke Crystal Accents  
Fondine Fabric Shades  
Susp. Hardware: 3 Ft. Chain

FINISH OPTION:

**S625** Polished Nickel

5.25"

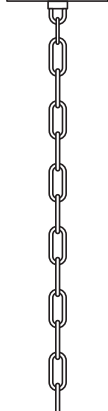

26.25" - 68.25" Adj.

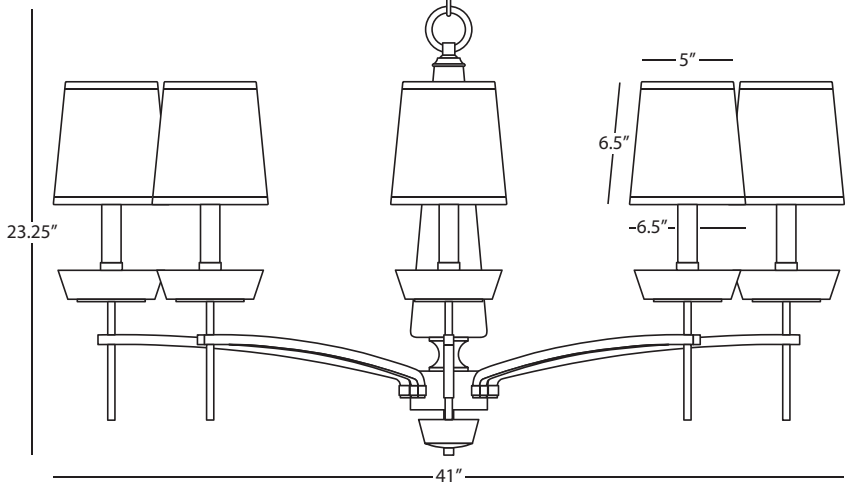

23.25"

5"

6.5"

6.5"

41"



S3609



3608

# Curtis

CURTIS

## S3609

### Floor Lamp

1 - 100W Max.  
Bulb Type: A  
Switch: Full Range Dimmer Foot Switch  
Deep Patina Bronze Finish  
Dark Antique Nickel Accents  
Oyster Linen Shade

FINISH OPTION:

**3609** Deep Patina Bronze  
Warm Brass Accents

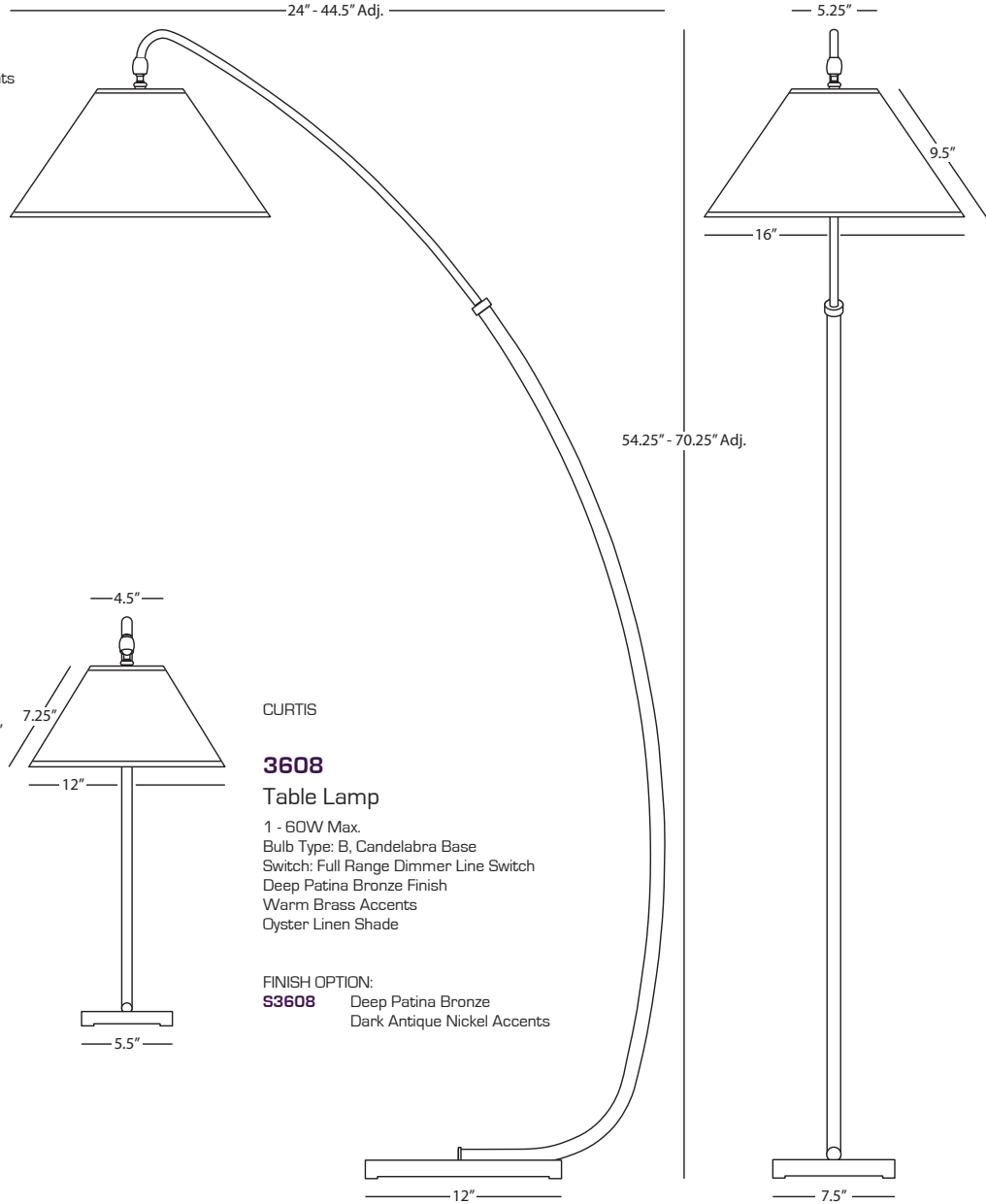

CURTIS

## 3608

### Table Lamp

1 - 60W Max.  
Bulb Type: B, Candelabra Base  
Switch: Full Range Dimmer Line Switch  
Deep Patina Bronze Finish  
Warm Brass Accents  
Oyster Linen Shade

FINISH OPTION:

**S3608** Deep Patina Bronze  
Dark Antique Nickel Accents



Z9870



9868



S9869



9871



Z9872

DAL

## Z9870

### Vessel Accent Lamp

1 - 100W Max.  
 Bulb Type: A  
 Switch: Hi-Lo Dimming  
 Hammered Metal Base  
 Deep Patina Bronze Finish  
 Oyster Linen Shade

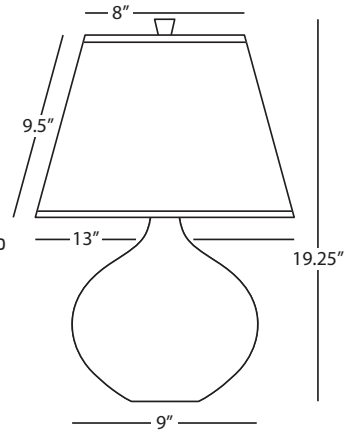

FINISH OPTIONS:

**9870** Modern Brass  
**S9870** Polished Nickel

DAL

## 9871

### Vessel Table Lamp

1 - 150W Max.  
 Bulb Type: A  
 Switch: Hi-Lo Dimming  
 Hammered Metal Base  
 Modern Brass Finish  
 Oyster Linen Shade

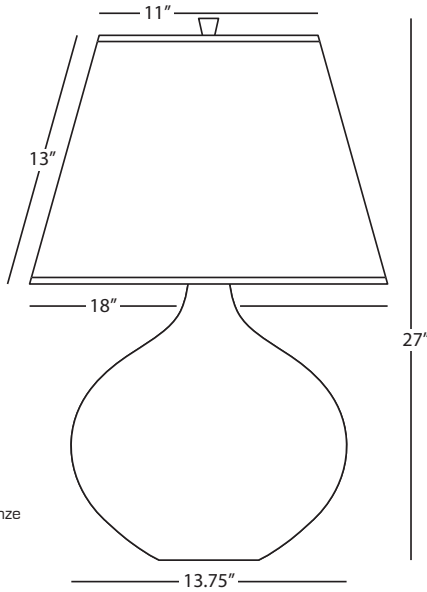

FINISH OPTIONS:

**S9871** Polished Nickel  
**Z9871** Deep Patina Bronze

DAL

## 9868

### Tapered Accent Lamp

1 - 150W Max.  
 Bulb Type: A  
 Switch: Hi-Lo Dimming  
 Hammered Metal Base  
 Modern Brass Finish  
 Oyster Linen Shade

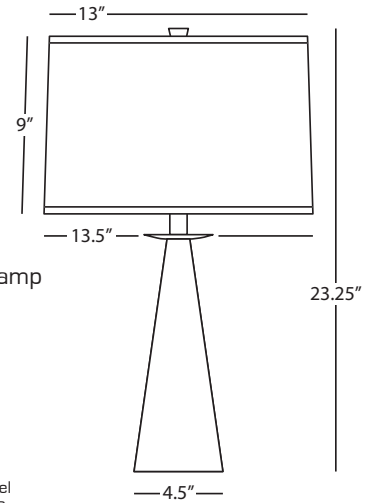

FINISH OPTIONS:

**S9868** Polished Nickel  
**Z9868** Deep Patina Bronze

DAL

## Z9872

### Tapered Square Table Lamp

1 - 150W Max.  
 Bulb Type: A  
 Switch: Hi-Lo Dimming  
 Hammered Metal Base  
 Deep Patina Bronze Finish  
 Oyster Linen Shade

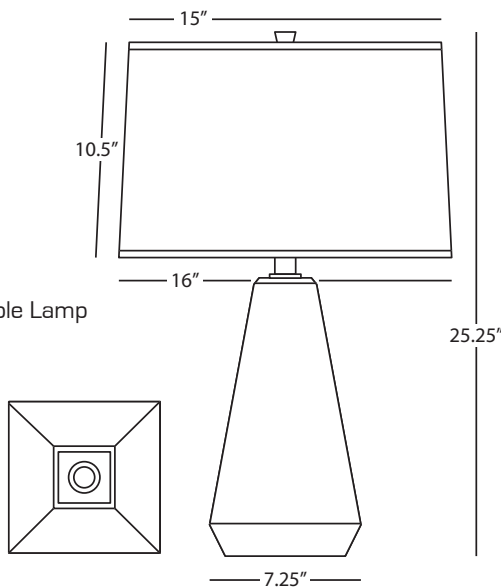

FINISH OPTIONS:

**9872** Modern Brass  
**S9872** Polished Nickel

DAL

## S9869

### Tapered Table Lamp

1 - 150W Max.  
 Bulb Type: A  
 Switch: Hi-Lo Dimming  
 Hammered Metal Base  
 Polished Nickel Finish  
 Oyster Linen Shade

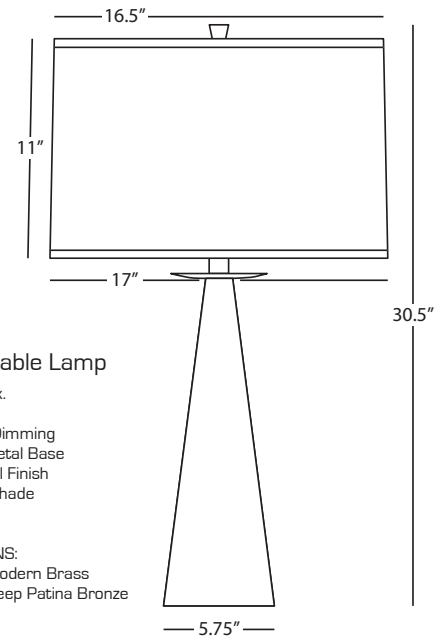

FINISH OPTIONS:

**9869** Modern Brass  
**Z9869** Deep Patina Bronze



C6900



6900



S6900



B6900



Z6900



# Daphne

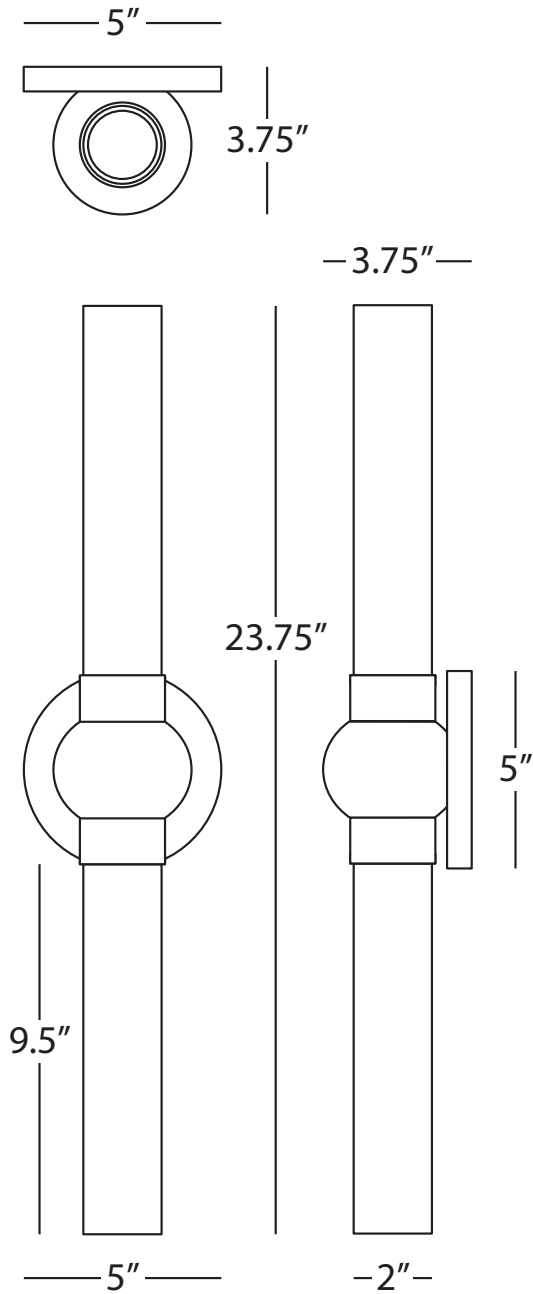

DAPHNE

## 6900 Wall Sconce

2 - 10W Max.  
(1600 Lumen Output)  
Bulb Type: LED unit, Included (Non-Replaceable)  
LED Color Temp: 3000, CRI: 90  
Direct Wire Only  
Modern Brass Finish  
Cased White Frosted Glass Shades  
UL Rated for Damp Locations  
ADA Compliant

### FINISH OPTIONS:

**B6900** Antique Silver  
**C6900** Chrome  
**S6900** Polished Nickel  
**Z6900** Deep Patina Bronze



AW137



PG138



SG137



VW138

# Decker

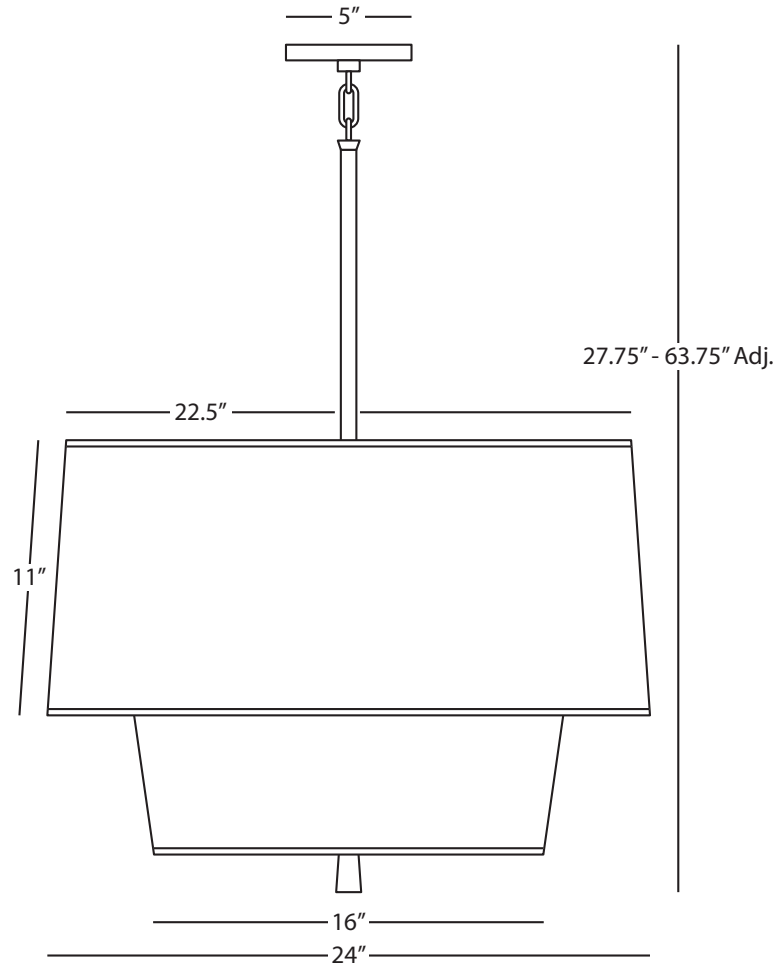

DECKER

## AW137

### Two-Tier Pendant

3 - 100W Max.

Bulb Type: A

Direct Wire

Modern Brass Finish

Two-Tier Ascot White Fabric Shade

14.5" Dia. White Acrylic Diffuser

Susp. Hardware: 1 pc. 5/8" x 6" & 3 pcs.

5/8" x 12" Extensions

#### FINISH/SHADE OPTIONS:

<b>PG137</b>	Modern Brass/Pearl Gray
<b>SG137</b>	Modern Brass/Smoke Gray
<b>VW137</b>	Modern Brass/Vintage Wine
<b>AW138</b>	Polished Nickel/Ascot White
<b>PG138</b>	Polished Nickel/Pearl Gray
<b>SG138</b>	Polished Nickel/Smoke Gray
<b>VW138</b>	Polished Nickel/Vintage Wine

# | Decker

---



# Decker

---

[Click photo above to watch Decker Wide Two-Tier Pendant Video](#)

The Decker collection features nested fabric shades that create a warm and inviting atmosphere. Decker comes in a variety of size and color options to accommodate your space perfectly.

---

# | Decker

---



# Decker

---

[Click photo above to watch Decker Three-Tier Pendant Video](#)

The Decker collection features nested fabric shades that create a warm and inviting atmosphere. Decker comes in a variety of size and color options to accommodate your space perfectly.

---



AW140



SG141



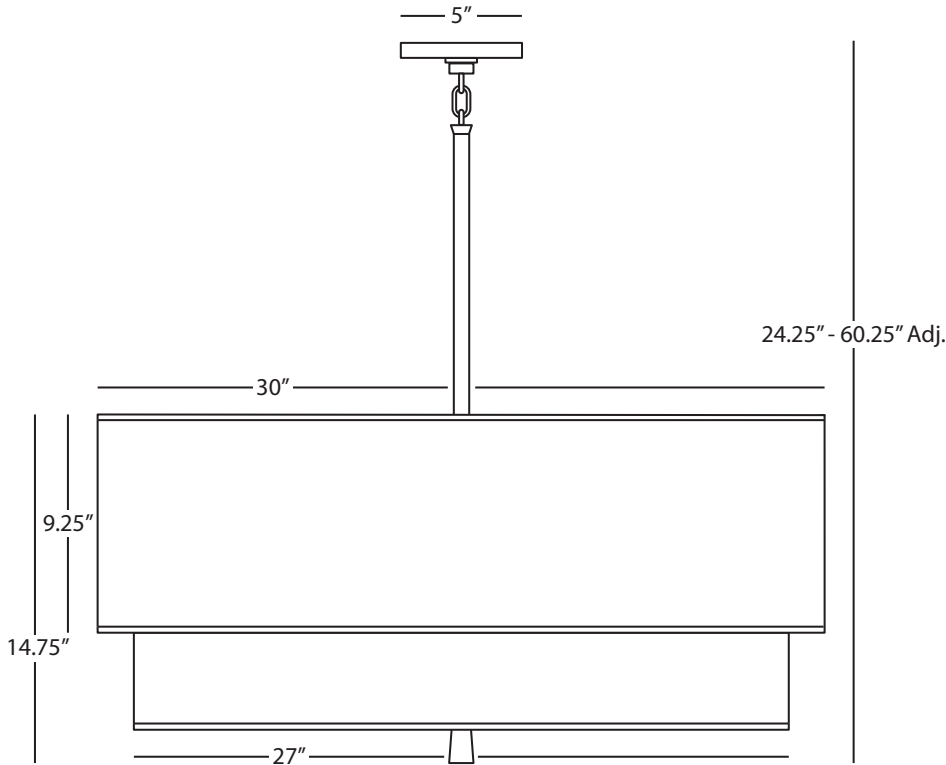

DECKER

## AW140

### Wide Two-Tier Pendant

3 - 100W Max.  
 Bulb Type: A  
 Direct Wire  
 Polished Nickel Finish  
 Wide Two-Tier Ascot White Fabric Shade  
 26.25" Dia. White Acrylic Diffuser  
 Susp. Hardware: 1 pc. 5/8" x 6" & 3 pcs. 5/8" x 12" Extensions

#### FINISH/SHADE OPTIONS:

<b>AW139</b>	Modern Brass/Ascot White
<b>PG139</b>	Modern Brass/Pearl Gray
<b>SG139</b>	Modern Brass/Smoke Gray
<b>VW139</b>	Modern Brass/Vintage Wine
<b>PG140</b>	Polished Nickel/Pearl Gray
<b>SG140</b>	Polished Nickel/Smoke Gray
<b>VW140</b>	Polished Nickel/Vintage Wine

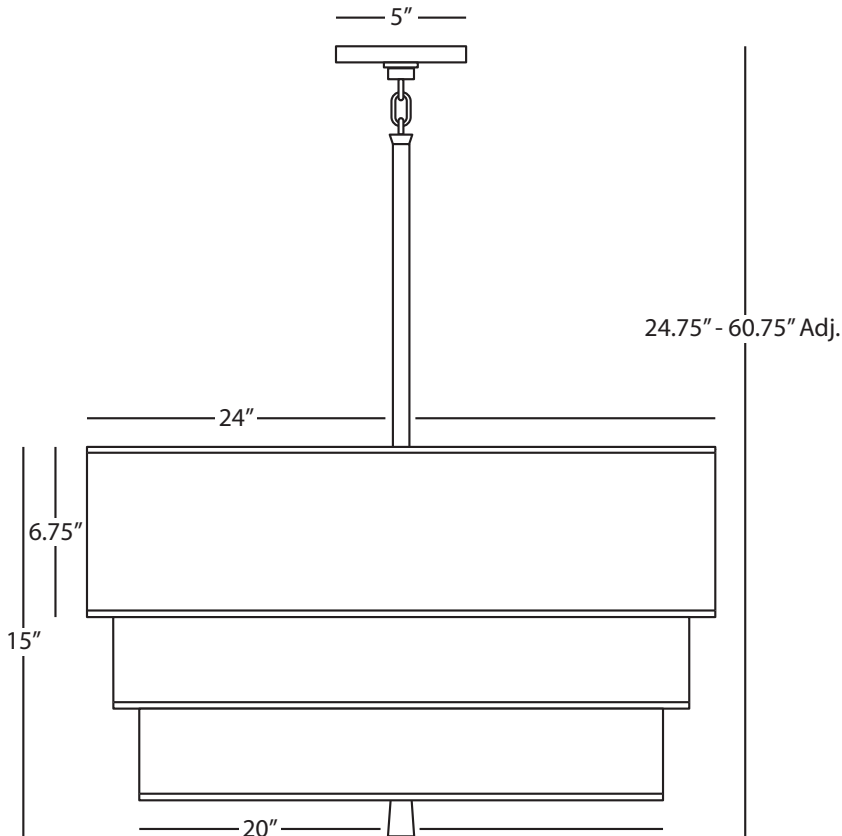

DECKER

## SG141

### Three-Tier Pendant

3 - 100W Max.  
 Bulb Type: A  
 Direct Wire  
 Modern Brass Finish  
 Three-Tier Smoke Gray Fabric Shade  
 19.25" Dia. White Acrylic Diffuser  
 Susp. Hardware: 1 pc. 5/8" x 6" & 3 pcs. 5/8" x 12" Extensions

#### FINISH/SHADE OPTIONS:

<b>AW141</b>	Modern Brass/Ascot White
<b>PG141</b>	Modern Brass/Pearl Gray
<b>VW141</b>	Modern Brass/Vintage Wine
<b>AW142</b>	Polished Nickel/Ascot White
<b>PG142</b>	Polished Nickel/Pearl Gray
<b>SG142</b>	Polished Nickel/Smoke Gray
<b>VW142</b>	Polished Nickel/Vintage Wine

# | Decker



# Decker

---

Click photo above to watch Decker Flush Mount video

The Decker collection features nested fabric shades that create a warm and inviting atmosphere. Decker comes in a variety of size and color options to accommodate your space perfectly.

---



AW143



AW144



PG143



PG144



SG143



SG144



VW143



VW144

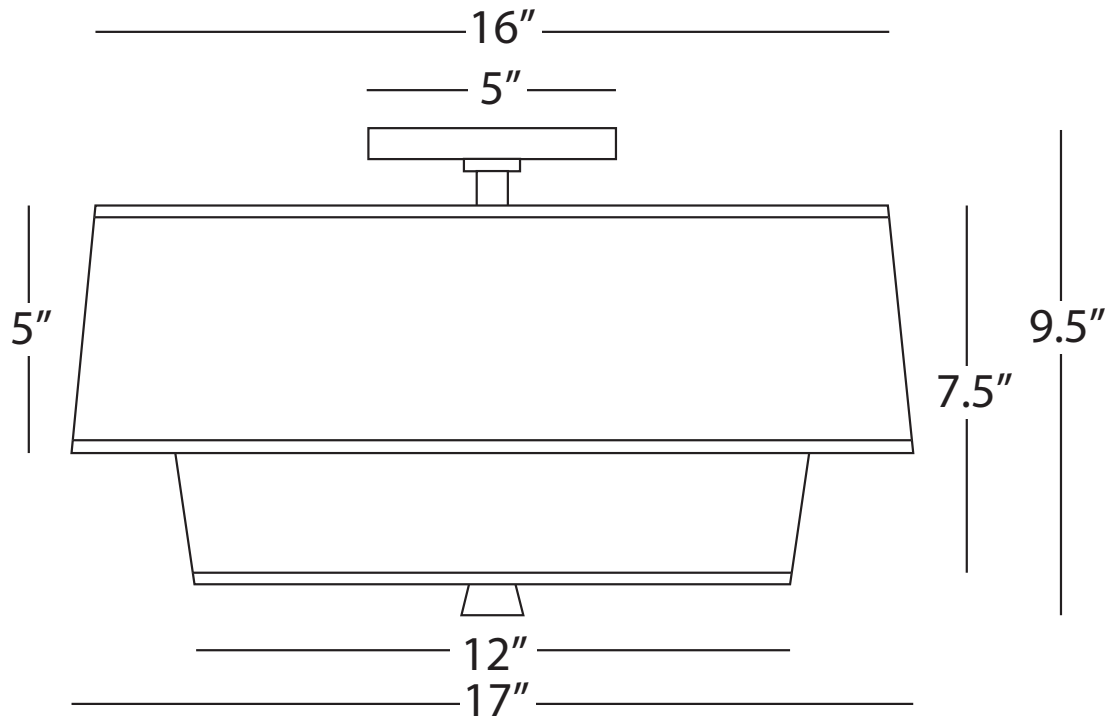

DECKER

## AW143

Flush Mount

2 - 60W Max.

Bulb Type: A

Direct Wire

Modern Brass Finish

Two-Tier Ascot White Fabric Shade

11.75" Dia. White Acrylic Diffuser

### FINISH/SHADE OPTIONS:

<b>PG143</b>	Modern Brass/Pearl Gray
<b>SG143</b>	Modern Brass/Smoke Gray
<b>VW143</b>	Modern Brass/Vintage Wine
<b>AW144</b>	Polished Nickel/Ascot White
<b>PG144</b>	Polished Nickel/Pearl Gray
<b>SG144</b>	Polished Nickel/Smoke Gray
<b>VW144</b>	Polished Nickel/Vintage Wine

# | Decker



# Decker

---

[Click photo above to watch Decker Table Lamp Video](#)

The Decker collection features nested fabric shades that create a warm and inviting atmosphere. Decker comes in a variety of size and color options to accommodate your space perfectly.

---

# | Decker

---

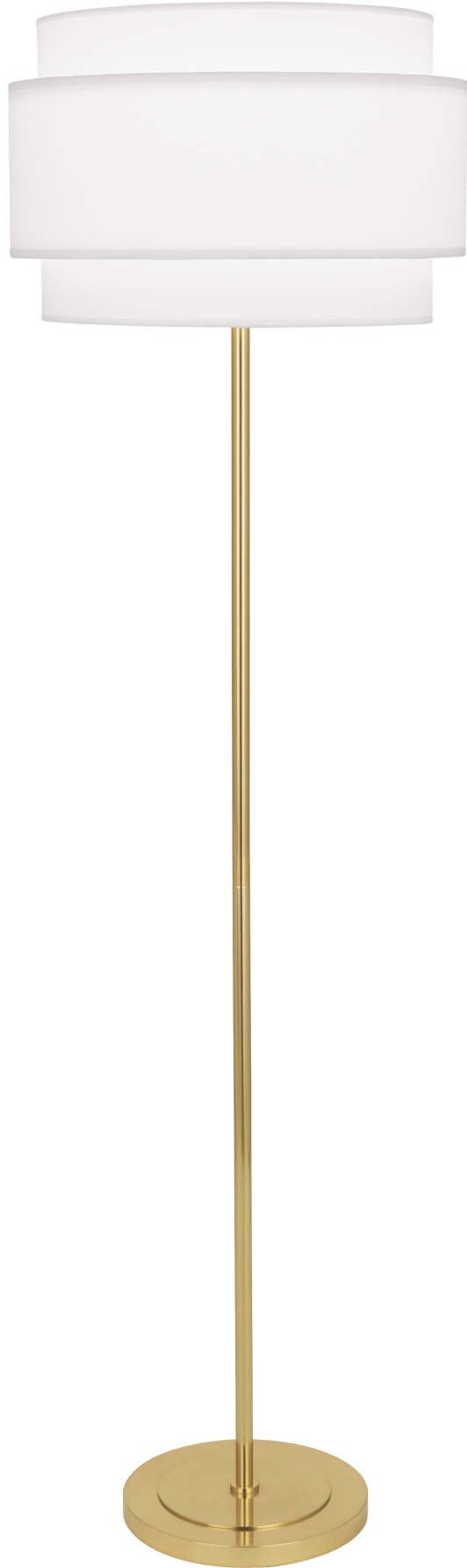



# Decker

---

[Click photo above to watch Decker Floor Lamp Video](#)

The Decker collection features nested fabric shades that create a warm and inviting atmosphere. Decker comes in a variety of size and color options to accommodate your space perfectly.

---

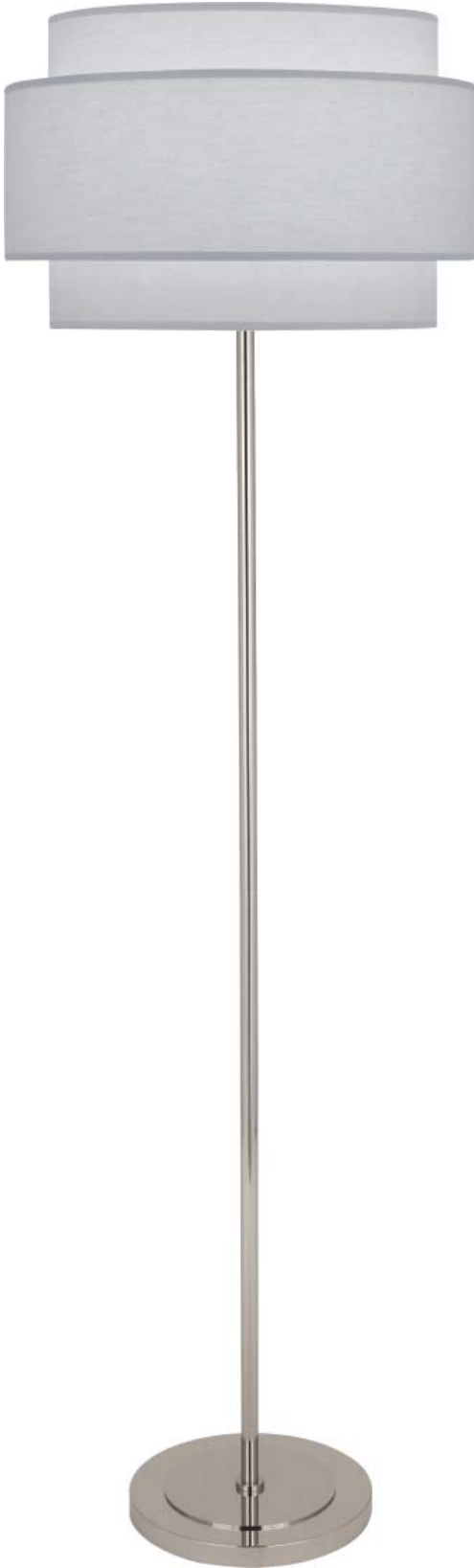

PG133



AW130

# Decker

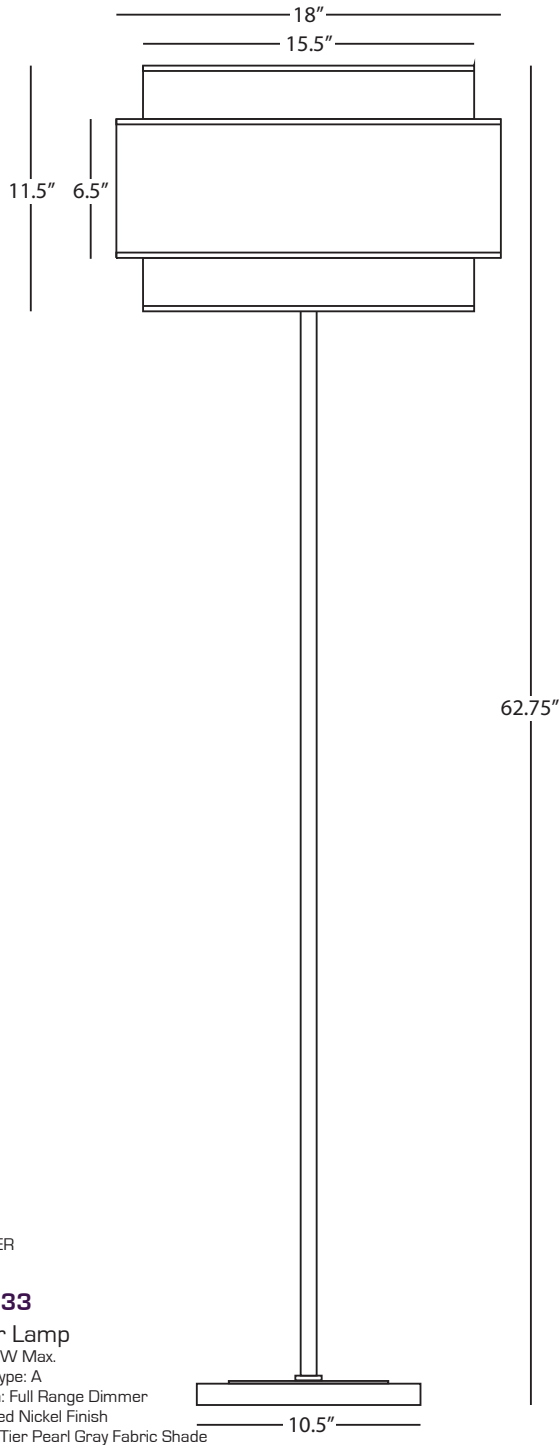

DECKER

## PG133

### Floor Lamp

1-150W Max.  
Bulb Type: A  
Switch: Full Range Dimmer  
Polished Nickel Finish  
Three-Tier Pearl Gray Fabric Shade

#### FINISH/SHADE OPTIONS:

**AW132** Modern Brass/Ascot White  
**PG132** Modern Brass/Pearl Gray  
**SG132** Modern Brass/Smoke Gray  
**VW132** Modern Brass/Vintage Wine  
**AW133** Polished Nickel/Ascot White  
**SG133** Polished Nickel/Smoke Gray  
**VW133** Polished Nickel/Vintage Wine

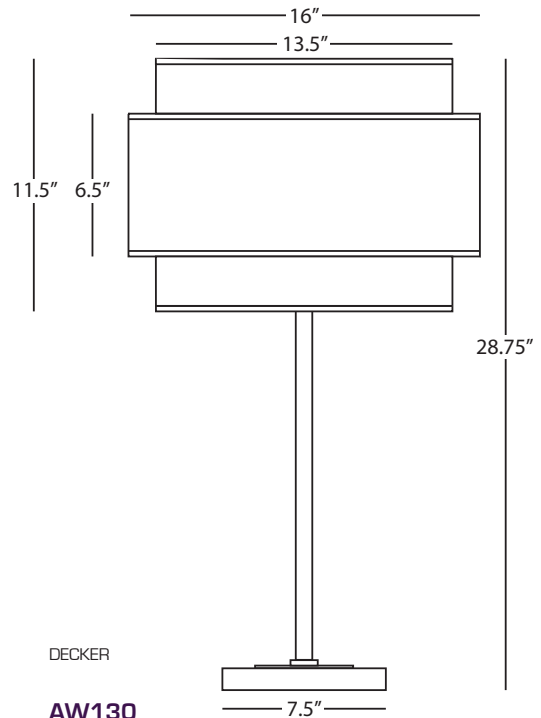

DECKER

## AW130

### Table Lamp

1-150W Max.  
Bulb Type: A  
Switch: Full Range Dimmer  
Modern Brass Finish  
Three-Tier Ascot White Fabric Shade

#### FINISH/SHADE OPTIONS:

**PG130** Modern Brass/Pearl Gray  
**SG130** Modern Brass/Smoke Gray  
**VW130** Modern Brass/Vintage Wine  
**AW131** Polished Nickel/Ascot White  
**PG131** Polished Nickel/Pearl Gray  
**SG131** Polished Nickel/Smoke Gray  
**VW131** Polished Nickel/Vintage Wine



4500



Z4500  
Shown with 4500N shades

# Delany

DELANY

## 4500 Chandelier

8 - 60W Max.  
Bulb Type: B, Candelabra  
1 - 35W Max. for Downlight  
Bulb Type: GU10 MR16 Halogen  
Direct Wire  
Antique Brass Finish  
Susp. Hardware: 1 pc. 5/8" x 6"  
& 3 pcs. 5/8" x 12" Extensions

FINISH OPTIONS:  
**24500** Deep Patina Bronze

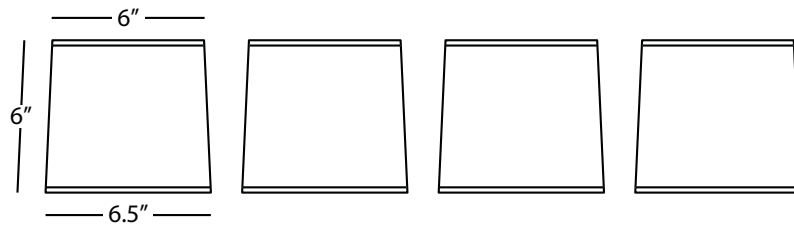
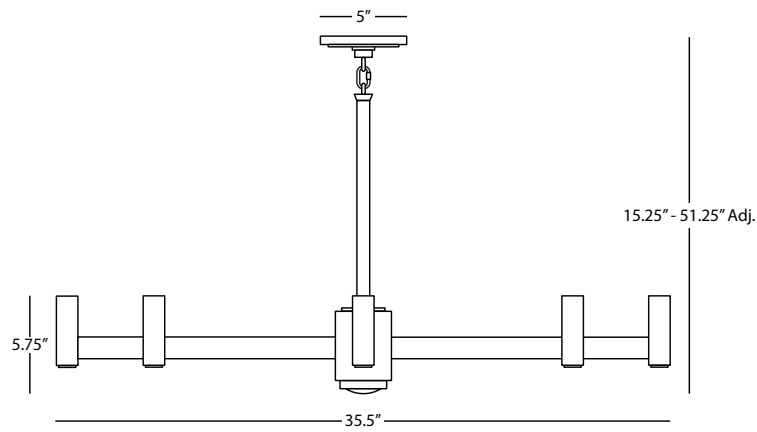
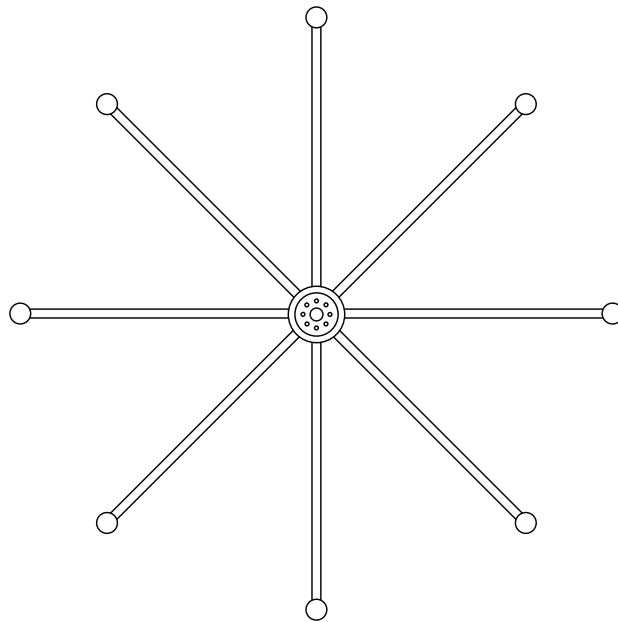

DELANY

## 4500N Shades Only

Oyster Linen Shades  
Nickel Candle Followers  
QTY: 8

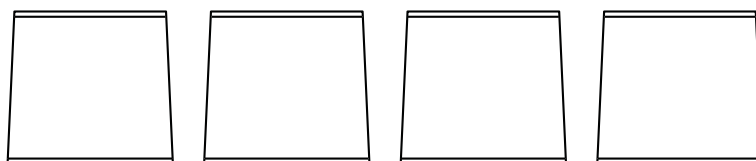

FINISH OPTION:  
**4500B** Brass Candle Followers



BN701



ML701



MB701



EB701

# Delilah

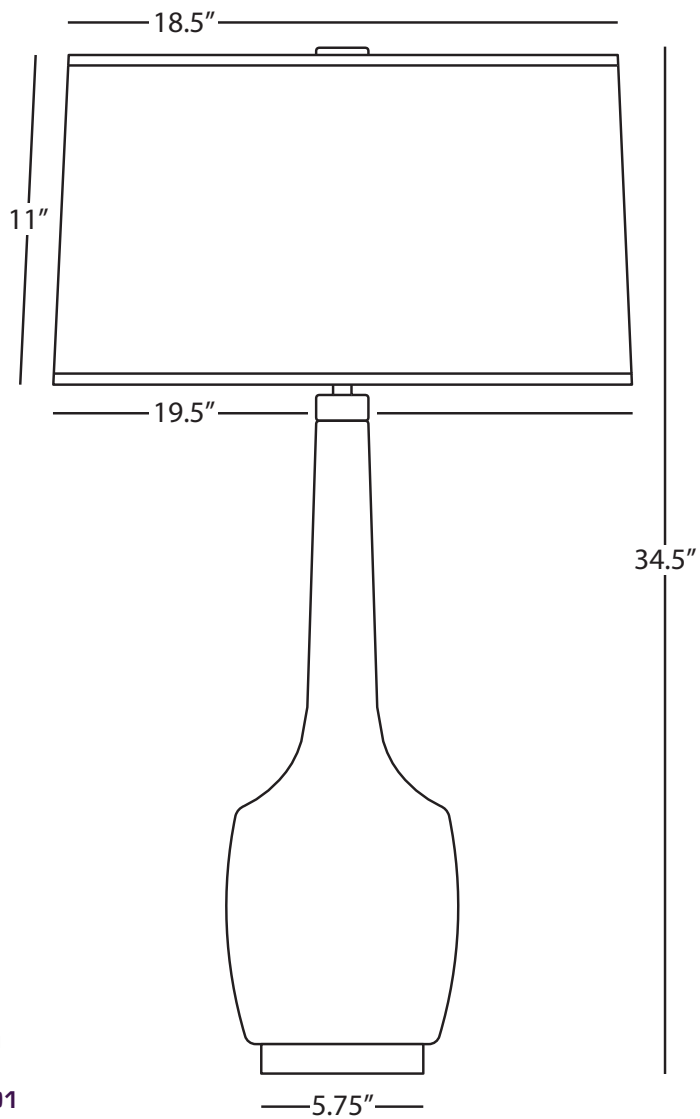

DELILAH

## **BN701**

Table Lamp

1 - 150W Max.  
Bulb Type: A  
Switch: Hi-Lo Dimming  
Bone Glazed Ceramic  
Antique Brass Finish  
Oyster Linen Shade w/ Self-Fabric  
Top and Bottom Diffuser

See Page 227 for Color Options



941



935



G930



946



942



MB930



# Delta

DELTA

## 935 Table Lamp

1 - 150W Max.  
Bulb Type: A  
Switch: 3-Way  
Apple Glazed Ceramic  
Polished Nickel Accents  
Oyster Linen Shade

See Page 227 for Color Options available w/ Oyster Linen Shade

FINISH/SHADE OPTION:

**G930** Polished Gold Glazed Ceramic w/  
Polished Brass Accents  
White Ceramic Parchment Shade w/ Gold Mylar Lining

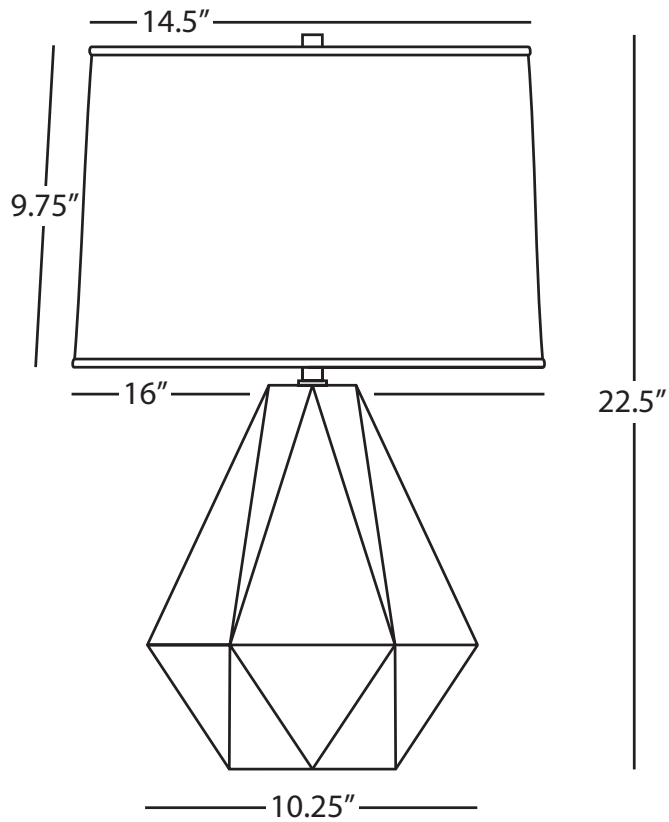
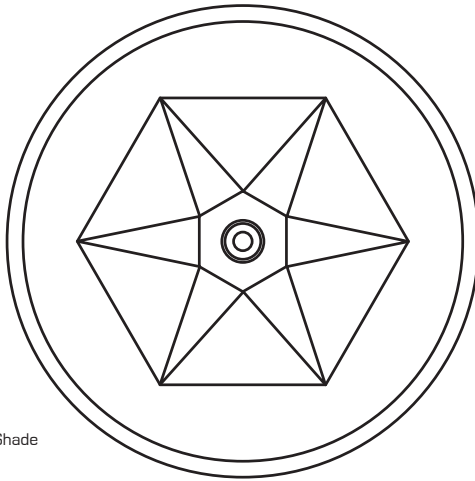



S206



205

# Dexter

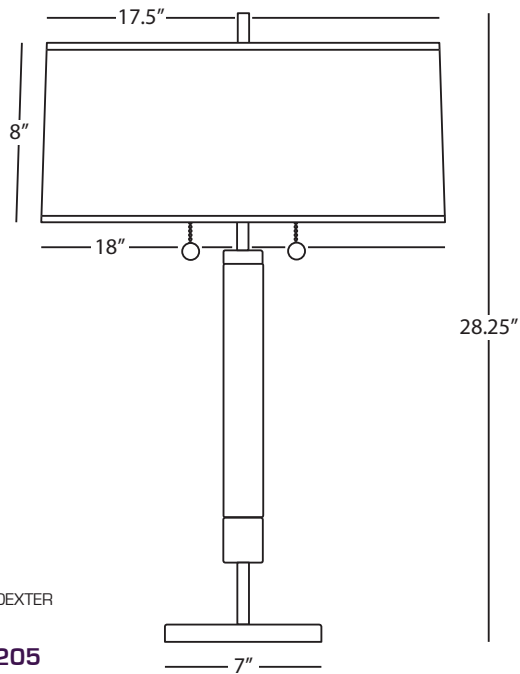

DEXTER

## 205

### Table Lamp

2 - 100W Max.  
 Bulb Type: A  
 Switch: On-Off Pull Chains  
 Modern Brass Finish  
 Walnut Finished Wood Column  
 Oyster Linen Shade

FINISH OPTION:

**S205** Polished Nickel/Dark Walnut Column

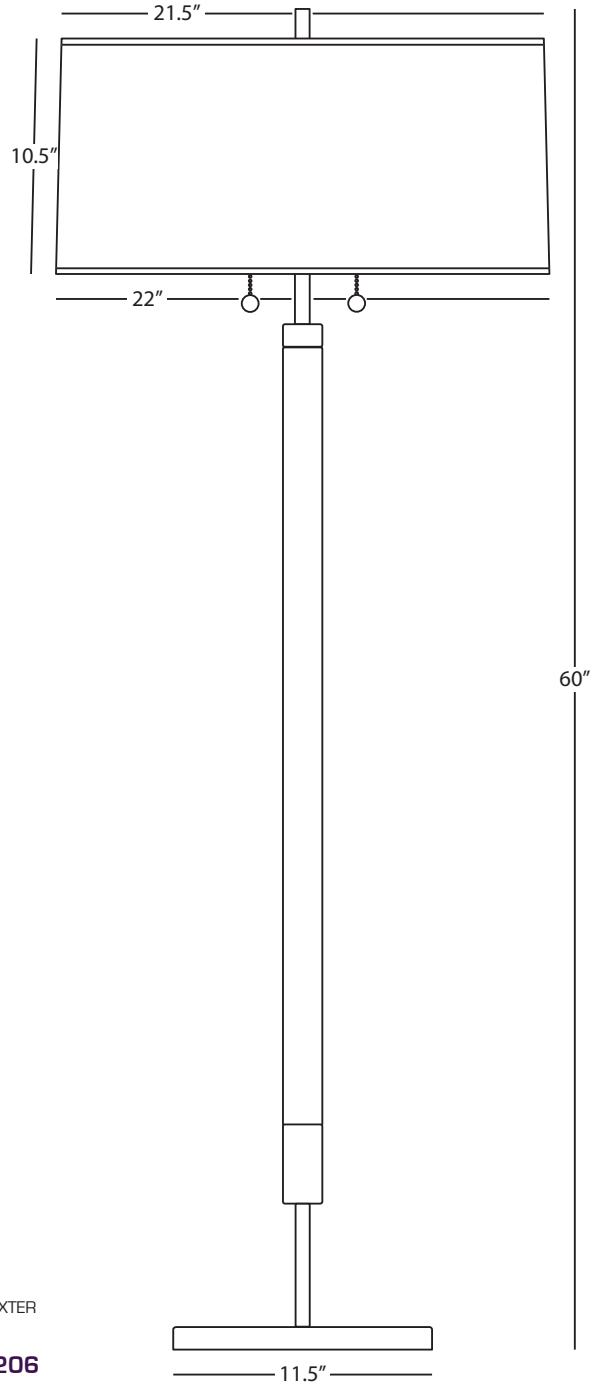

DEXTER

## S206

### Floor Lamp

2 - 100W Max.  
 Bulb Type: A  
 Switch: On-Off Pull Chains  
 Polished Nickel Finish  
 Dark Walnut Finished Wood Column  
 Oyster Linen Shade

FINISH OPTION:

**206** Modern Brass/Walnut Column



204

# Diana

DIANA

**204**

Pendant

8 - 60W Max.  
Bulb Type: B, Candelabra  
Direct Wire  
Warm Brass Finish w/  
Antiqued Mirror Accents  
Susp. Hardware: 3 Ft. Chain

FINISH OPTION:  
**S204** Antique Silver

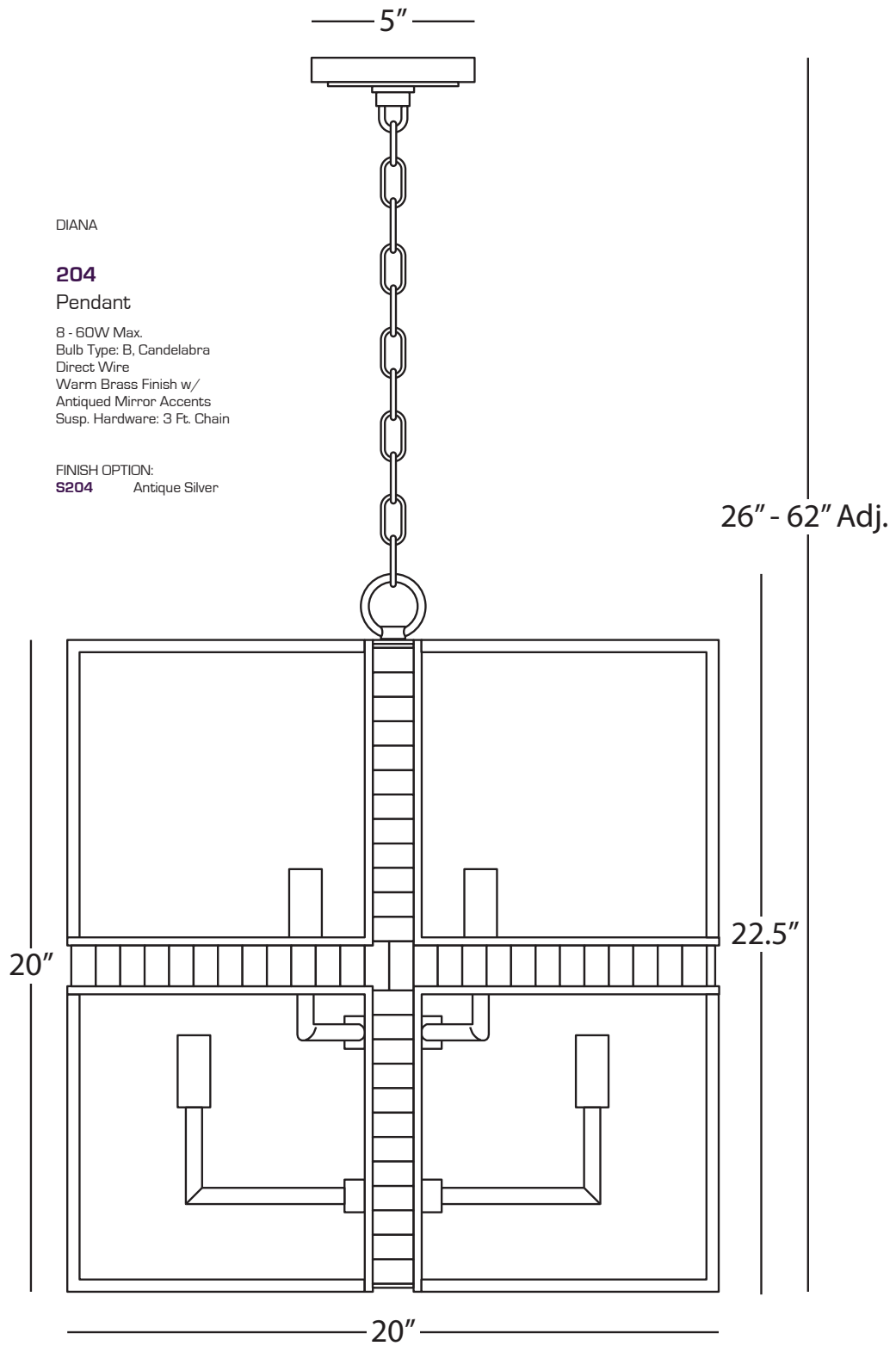



Z1547



Z1546

# Director

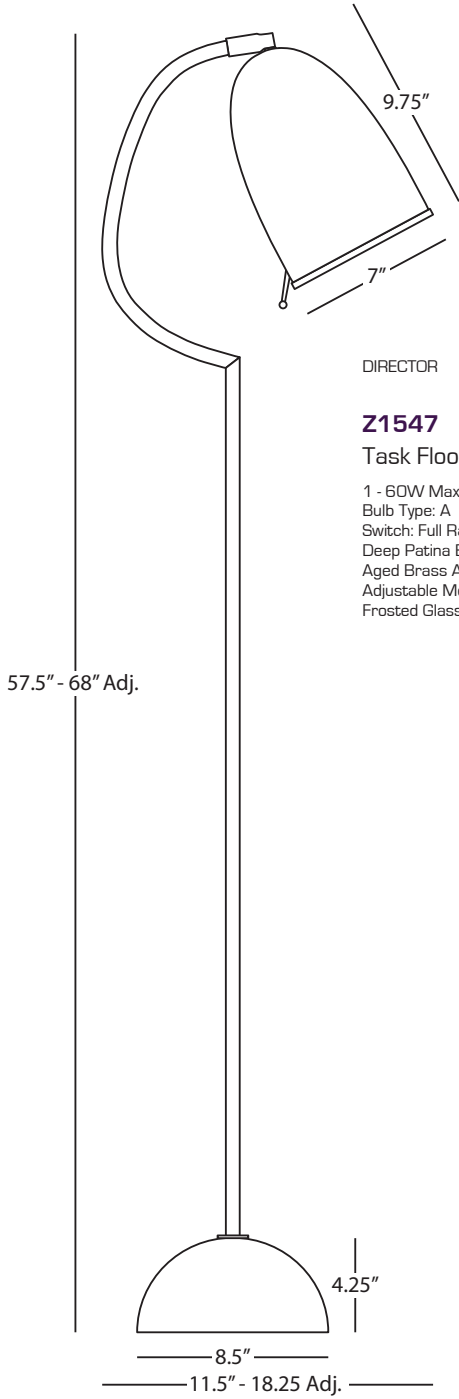

DIRECTOR

**Z1547**

Task Floor Lamp

1 - 60W Max.  
Bulb Type: A  
Switch: Full Range Dimmer Foot Switch  
Deep Patina Bronze Finish  
Aged Brass Accents  
Adjustable Metal Shade w/  
Frosted Glass Diffuser

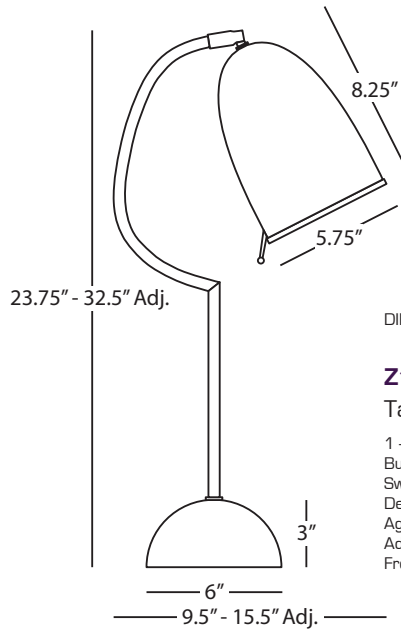

DIRECTOR

**Z1546**

Task Table Lamp

1 - 60W Max.  
Bulb Type: A  
Switch: Hi-Lo Line Switch  
Deep Patina Bronze Finish  
Aged Brass Accents  
Adjustable Metal Shade w/  
Frosted Glass Diffuser



BN801



AM801



BB801



PC800



ST800



MB800



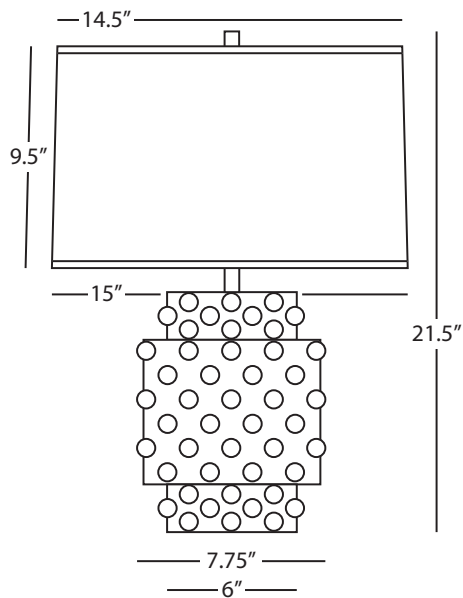

DOLLY

## AM801

### Accent Lamp

1 - 150W Max.  
Bulb Type: A  
Switch: Full Range Dimmer  
Amethyst Glazed Textured Ceramic  
Fondine Fabric Shade

See Page 228 for Color Options

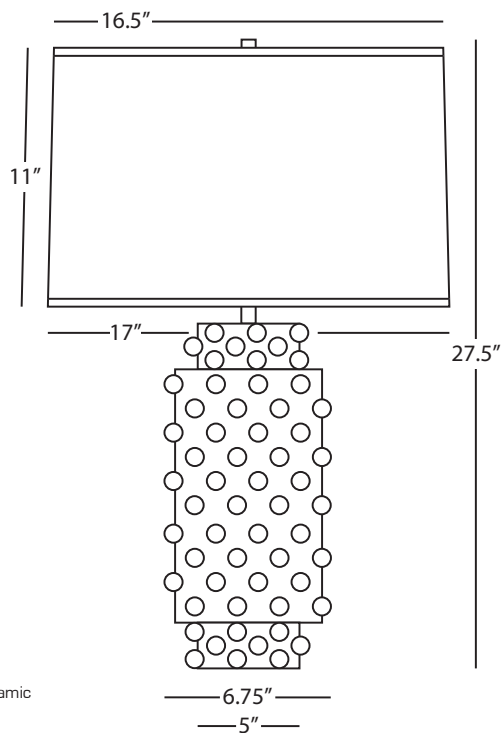

DOLLY

## MB800

### Table Lamp

1 - 150W Max.  
Bulb Type: A  
Switch: Full Range Dimmer  
Midnight Blue Glazed Textured Ceramic  
Fondine Fabric Shade

See Page 228 for Color Options



G801B



S801



800



G800

DOLLY

## G801B

### Accent Lamp

1 - 150W Max.  
 Bulb Type: A  
 Switch: Hi-Lo Dimming  
 Textured Ceramic w/  
 Gold Metallic Glaze  
 Black Opaque Parchment Shade  
 w/ Gold Foil Lining

FINISH/SHADE OPTIONS:

- 801** Gunmetal Glaze  
Fondine Fabric
- G801** Gold Metallic Glaze  
Fondine Fabric
- S801** Nickel Metallic Glaze  
Fondine Fabric Shade
- S801B** Nickel Metallic Glaze  
Black Parchment w/  
Silver Foil Lining

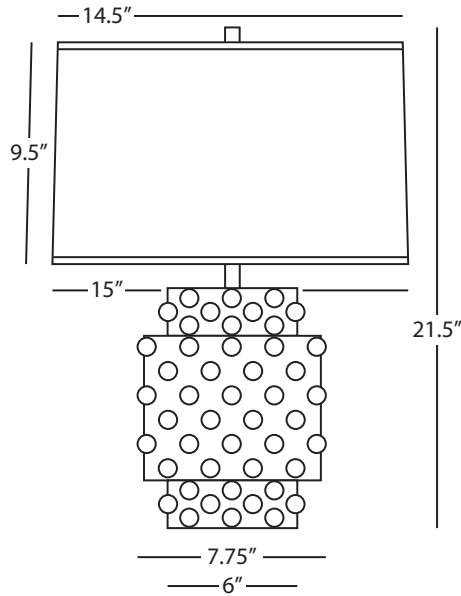

DOLLY

## 800

### Table Lamp

1 - 150W Max.  
 Bulb Type: A  
 Switch: Hi-Lo Dimming  
 Textured Ceramic w/  
 Gunmetal Glaze  
 Fondine Fabric Shade

FINISH/SHADE OPTIONS:

- G800** Gold Metallic Glaze  
Fondine Fabric
- G800B** Gold Metallic Glaze  
Black Parchment w/  
Gold Foil Lining
- S800** Nickel Metallic Glaze  
Fondine Fabric Shade
- S800B** Nickel Metallic Glaze  
Black Parchment w/  
Silver Foil Lining

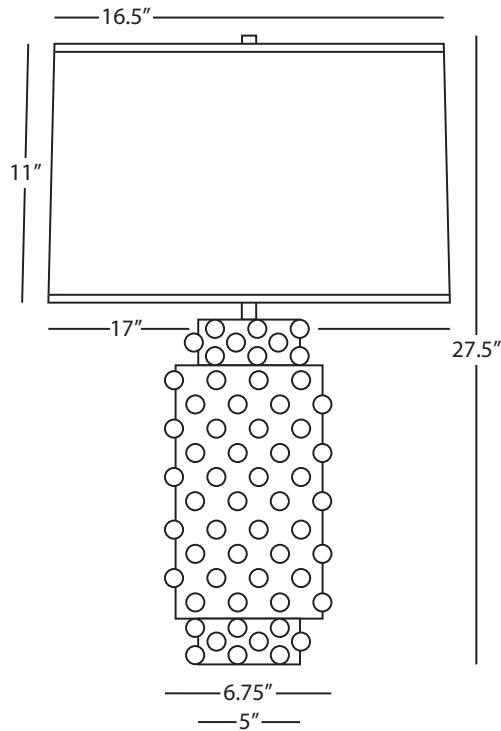

# Double Gourd



1772X



1617



A770X



CF23X



1673

# Double Gourd

DOUBLE GOURD

## A770X Accent Lamp

1 - 150W Max.  
Bulb Type: A  
Switch: 3-Way  
Smoky Taupe Glazed Ceramic  
Round Lucite Base  
Pearl Dupioni Fabric Shade

See Page 229 for  
Color/Base/Shade Options

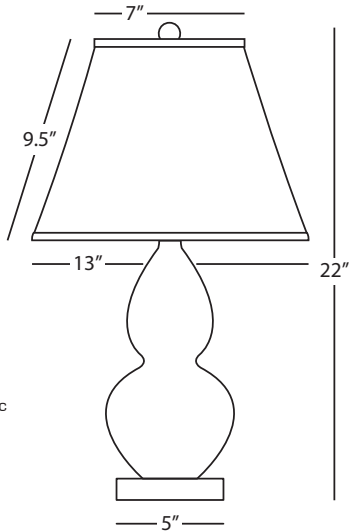

DOUBLE GOURD

## 1617 Accent Lamp

1 - 150W Max.  
Bulb Type: A  
Switch: 3-Way  
Schiaparelli Pink Glazed Ceramic  
Antique Brass Finished Accents  
Ivory Stretched Fabric Shade

See Page 229 for  
Color/Base/Shade Options

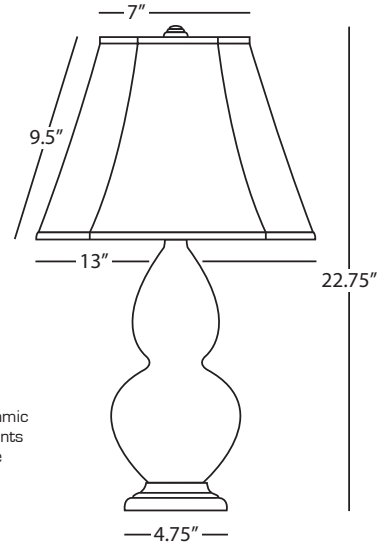

DOUBLE GOURD

## 1673 Table Lamp

1 - 150W Max.  
Bulb Type: A  
Switch: 3-Way  
Apple Glazed Ceramic  
Antique Silver Finished Accents  
Ivory Stretched Fabric Shade

See Page 229 for  
Color/Base/Shade Options

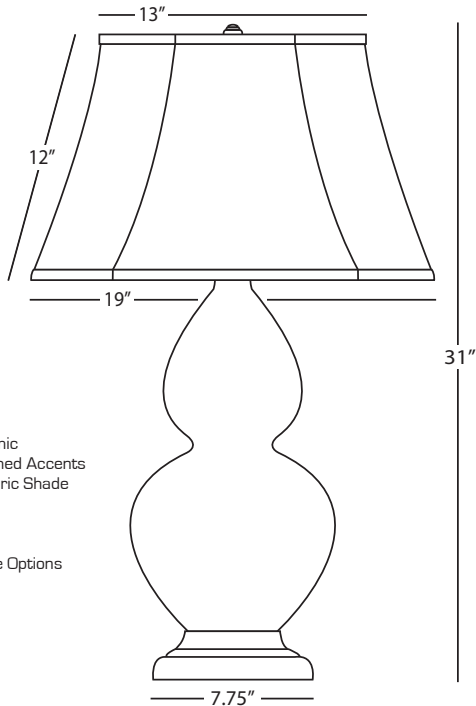

DOUBLE GOURD

## CF23X Table Lamp

1 - 150W Max.  
Bulb Type: A  
Switch: 3-Way  
Coffee Glazed Ceramic  
Round Lucite Base  
Pearl Dupioni Fabric Shade

See Page 229 for  
Color/Base/Shade Options

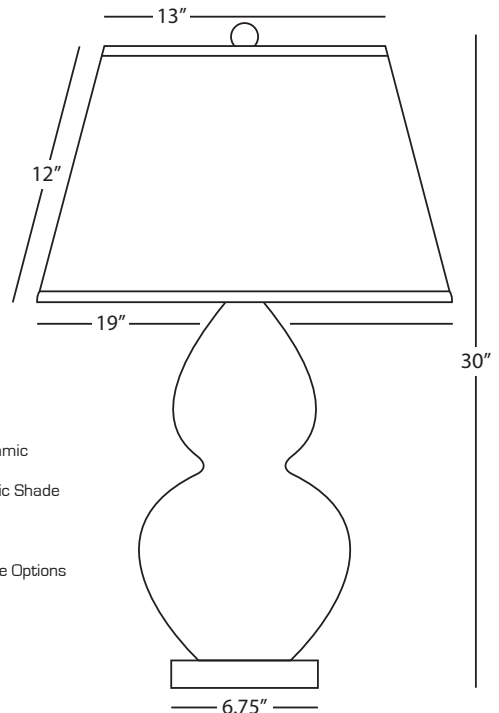



103XBN



102XBZ

# Doughnut

DOUGHNUT

## 102XBZ

### Duncan Table Lamp

1 - 150W Max.  
 Bulb Type: A  
 Switch: 3-Way  
 Deep Patina Bronze Finish  
 Ebony Finished Wood Base  
 Rectangular Snowflake Fabric Shade

FINISH OPTIONS:  
**100XBN** Natural Brass  
**101XAS** Antique Silver

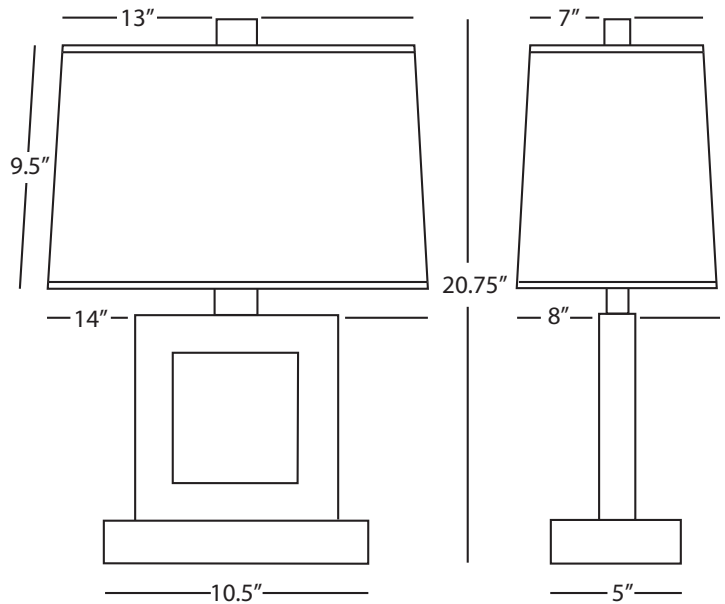

DOUGHNUT

## 103XBN

### Jerry Table Lamp

1 - 150W Max.  
 Bulb Type: A  
 Switch: 3-Way  
 Natural Brass Finish  
 Ebony Finished Wood Base  
 Rectangular Snowflake Fabric Shade

FINISH OPTIONS:  
**104XAS** Antique Silver  
**105XBZ** Deep Patina Bronze

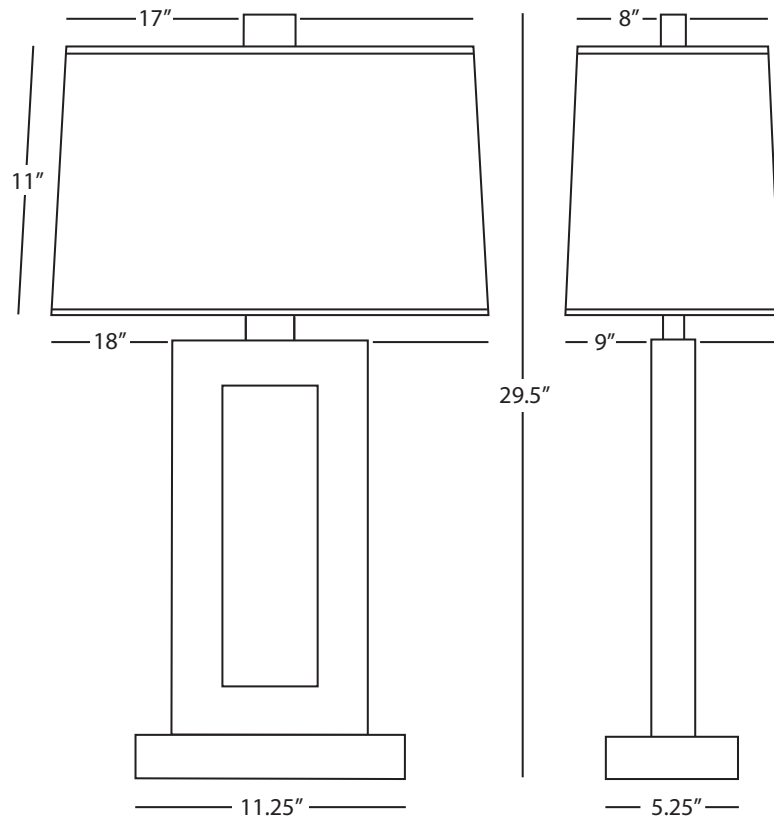

Doughnut



147



Z149



# Doughnut

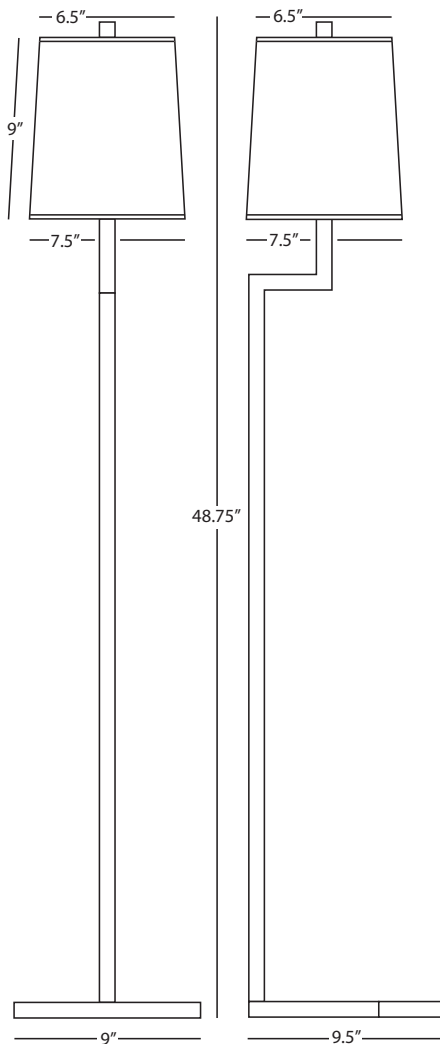

DOUGHNUT

## Z149 Mini "C" Floor Lamp

1 - 100W Max.  
Bulb Type: A  
Switch: Full Range Dimmer  
Deep Patina Bronze Finish  
Square Snowflake Fabric Shade  
w/ Top Diffuser

FINISH OPTIONS:  
**149** Natural Brass  
**S149** Antique Silver

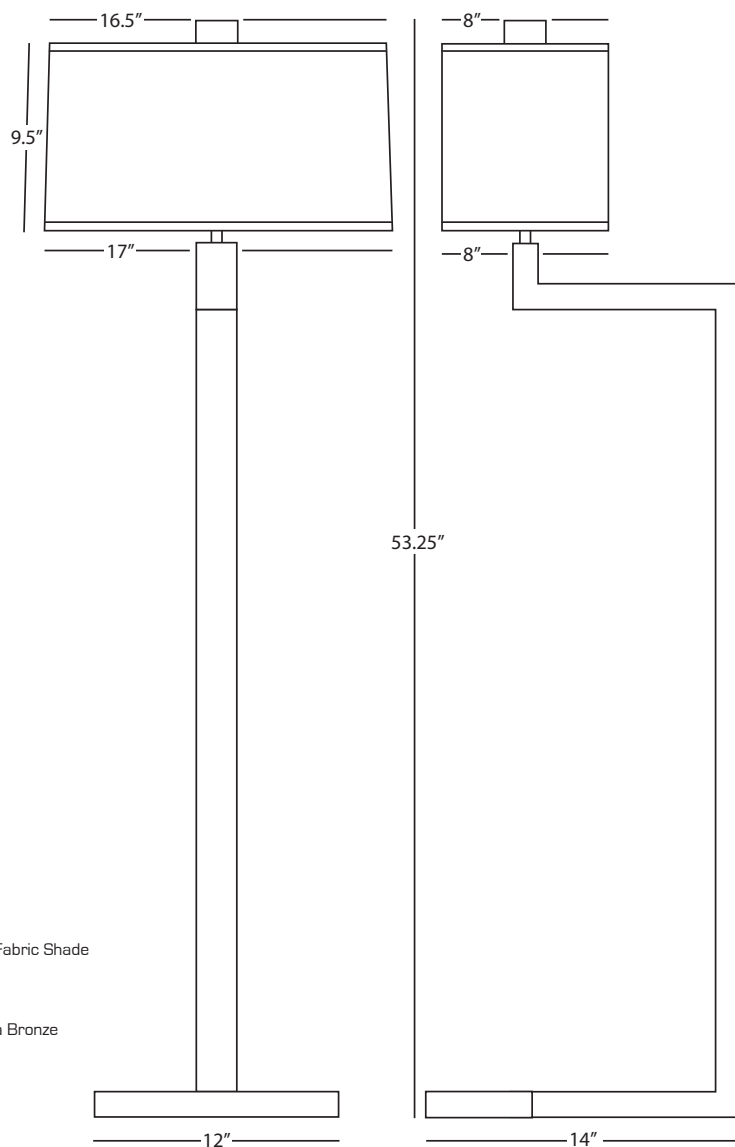

DOUGHNUT

## 147 "C" Floor Lamp

2 - 100W Max.  
Bulb Type: A  
Switch: Hi-Lo Dimming  
Antique Silver Finish  
Rectangular Snowflake Fabric Shade

FINISH OPTION:  
**148** Deep Patina Bronze

# Doughnut

139



Z139



S139



106X



107X



108X



# Doughnut

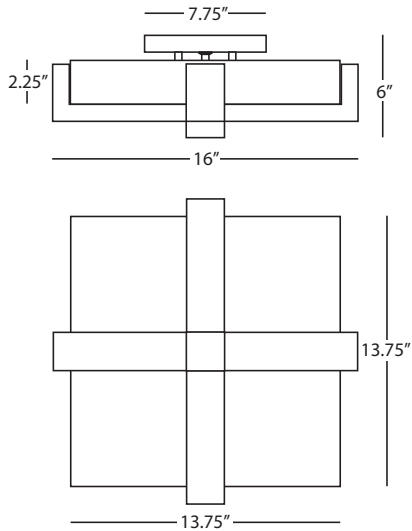

DOUGHNUT

## 139 Flush Mount

2 - 60W Max.  
Bulb Type: T-10 Medium Base  
Direct Wire Only  
Natural Brass Finish  
Marbleized Glass Shade

FINISH OPTIONS:  
**S139**    Antique Silver  
**Z139**    Deep Patina Bronze

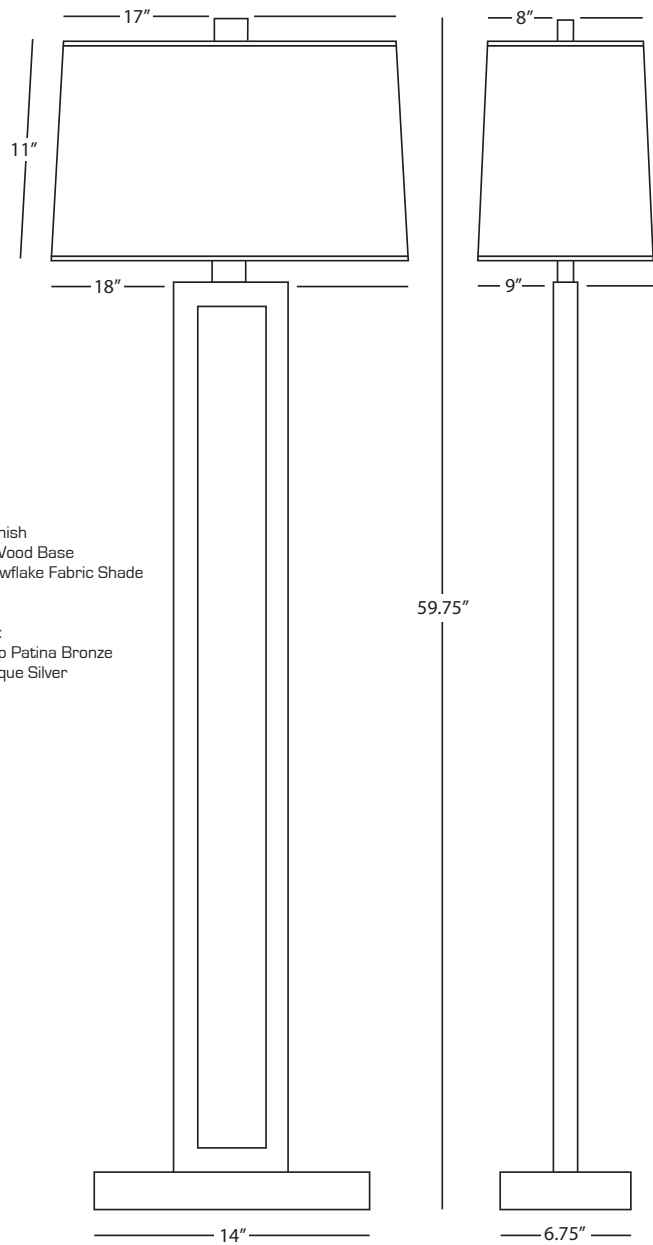

DOUGHNUT

## 106X Floor Lamp

1 - 150W Max.  
Bulb Type: A  
Switch: 3-Way  
Natural Brass Finish  
Ebony Finished Wood Base  
Rectangular Snowflake Fabric Shade

FINISH OPTIONS:  
**107X**    Deep Patina Bronze  
**108X**    Antique Silver



115



S115



Z115

# Doughnut

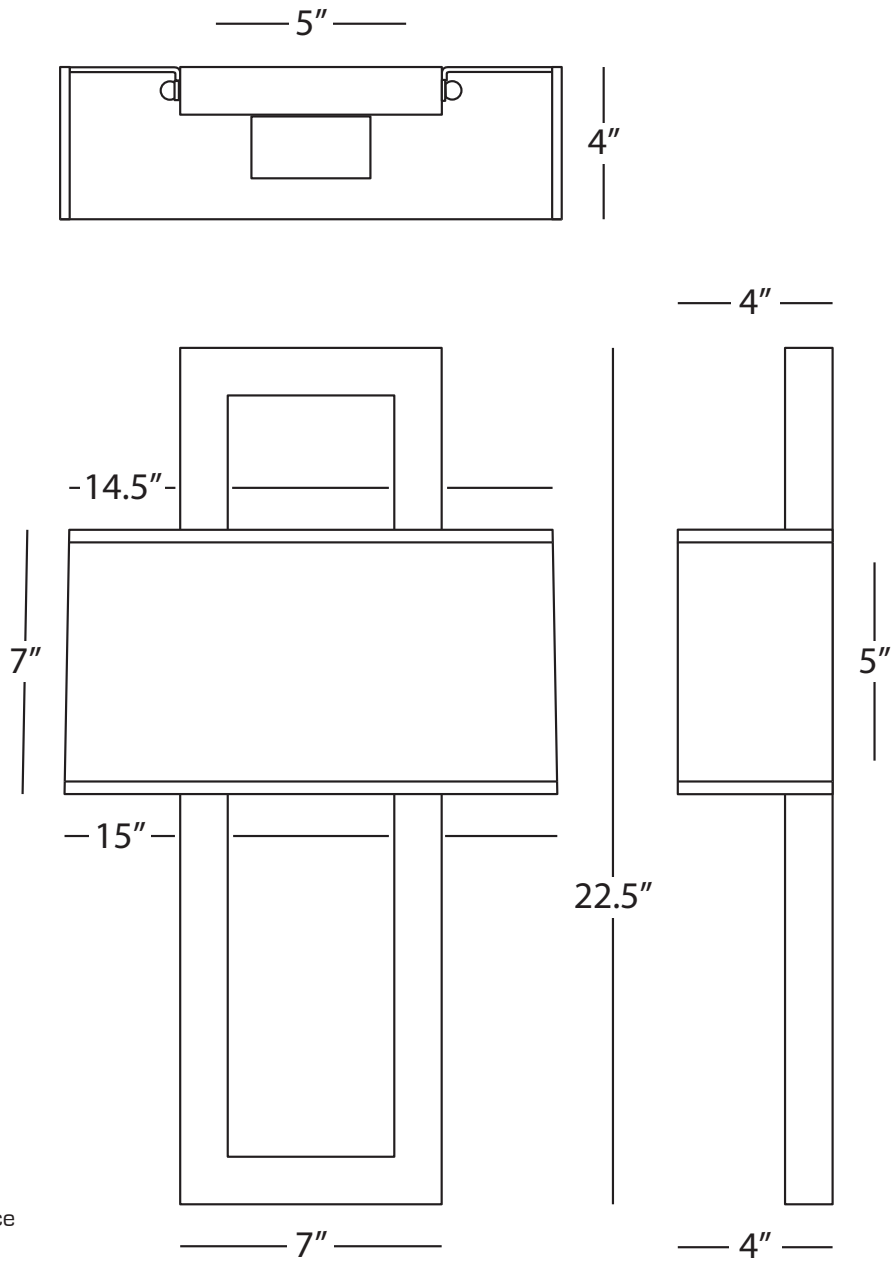

DOUGHNUT

**115**

Wall Sconce

2 - 25W Max.  
Bulb Type: B, Medium Base  
Direct Wire Only  
Antique Brass Finish  
Rectangular Snowflake Fabric Shade  
ADA Compliant

FINISH OPTIONS:

**S115**    Antique Silver  
**Z115**    Deep Patina Bronze



Z2170



S2181



S2184



Z2175

# Echo

ECHO

## S2184 Accent Lamp

1 - 60W Max.  
Bulb Type: G16.5 Candelabra  
Switch: On-Off Line Switch  
Stainless Steel Finish  
Fondine Fabric Shade

FINISH OPTION:

**Z2174** Deep Patina Bronze

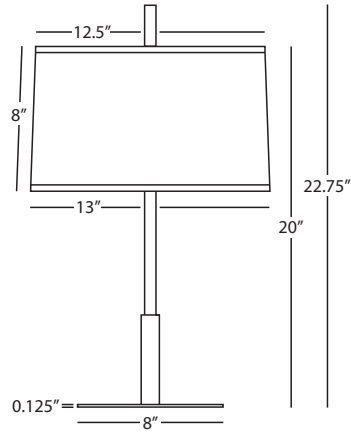

ECHO

## Z2175 Buffet Lamp

1 - 60W Max.  
Bulb Type: G16.5 Candelabra  
Switch: On-Off Line Switch  
Deep Patina Bronze Finish  
Fondine Fabric Shade

FINISH OPTION:

**S2185** Stainless Steel

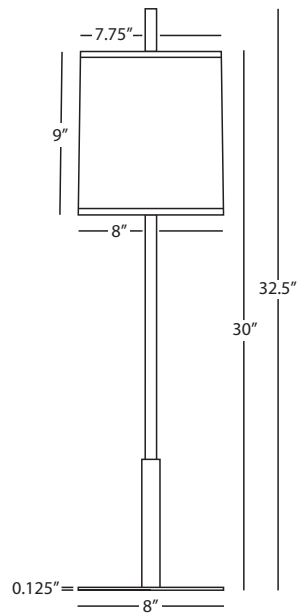

ECHO

## Z2170 Table Lamp

1 - 150W Max.  
Bulb Type: A  
Switch: 3-Way  
Deep Patina Bronze Finish  
Fondine Fabric Shade

FINISH OPTION:

**S2180** Stainless Steel

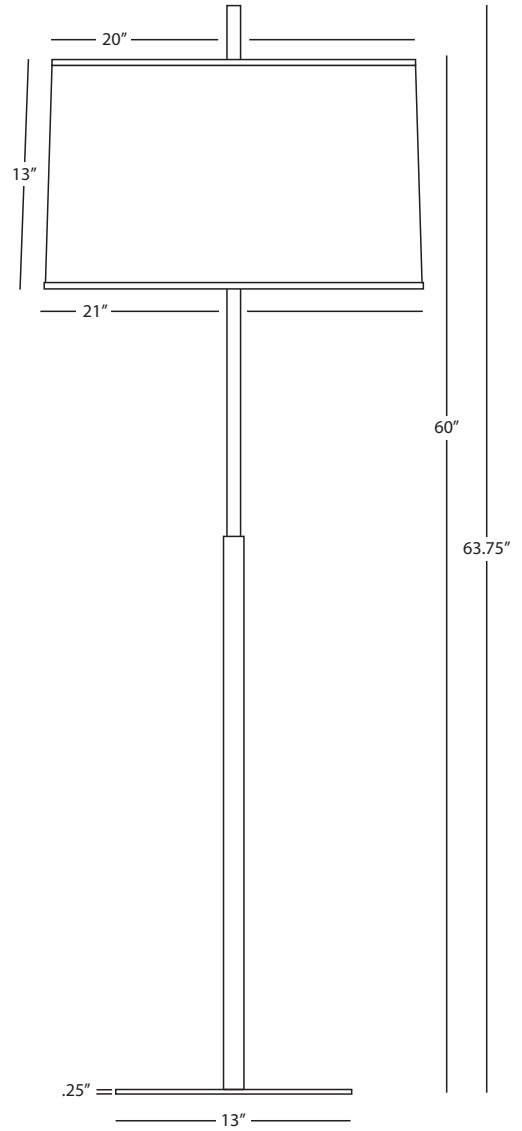
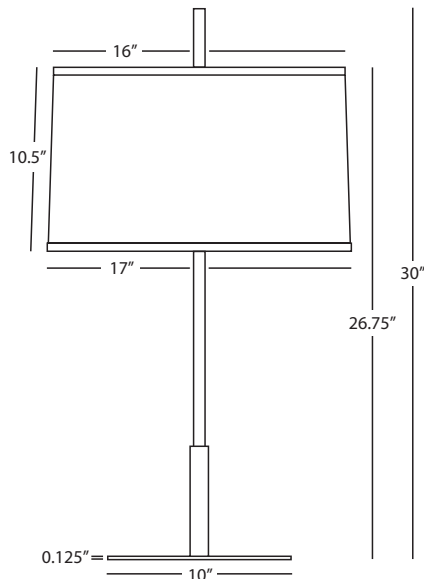

ECHO

## S2181 Floor Lamp

1 - 150W Max.  
Bulb Type: A  
Switch: 3-Way  
Stainless Steel Finish  
Fondine Fabric Shade

FINISH OPTION:

**Z2171** Deep Patina Bronze



Z2179



S2186



Z2172



S2188



# Echo

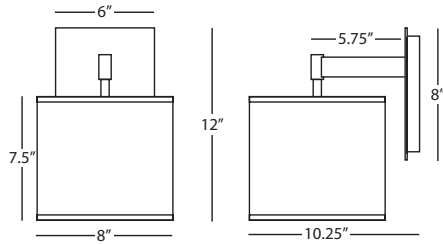

ECHO

## Z2172 Wall Sconce

1 - 60W Max.  
Bulb Type: B, Candelabra  
Switch: On-Off Line Switch  
24" Cord Cover/Direct Wire  
Deep Patina Bronze Finish  
Fondine Fabric Shade

FINISH OPTION:  
**S2182** Stainless Steel

ECHO

## Z2179 Pendant

3 - 100W Max.  
Bulb Type: A  
Direct Wire Only  
Deep Patina Bronze Finish  
Fondine Fabric Shade  
19" Dia. Acrylic Diffuser  
Susp. Hardware: 3 pcs. 5/8" x 12" &  
1 pc. 5/8" x 6" Extensions

FINISH OPTION:  
**S2189** Stainless Steel

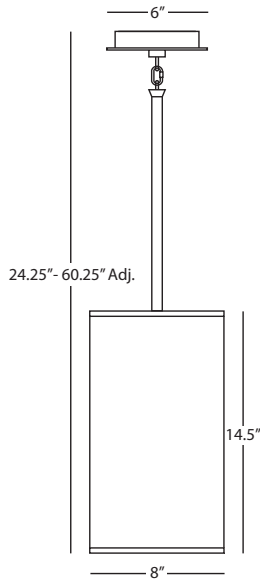
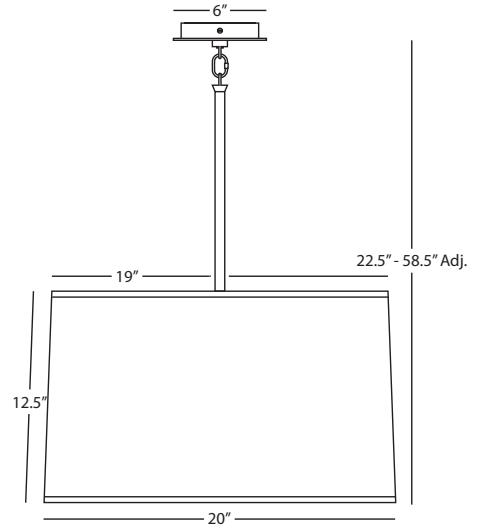

ECHO

## S2186 Narrow Pendant

1 - 60W Max.  
Bulb Type: B, Candelabra  
Direct Wire Only  
Stainless Steel Finish  
Fondine Fabric Shade  
Susp. Hardware: 3 pcs. 5/8" x 12" &  
1 pc. 5/8" x 6" Extensions

FINISH OPTION:  
**Z2176** Deep Patina Bronze

ECHO

## S2188 6-Light Chandelier

6 - 60W Max.  
Bulb Type: G16.5 Candelabra  
Direct Wire Only  
Stainless Steel Finish  
Fondine Fabric Shades  
Susp. Hardware: 3 pcs. 5/8" x 12"  
& 1 pc. 5/8" x 6" Extensions

FINISH OPTION:  
**Z2178** Deep Patina Bronze

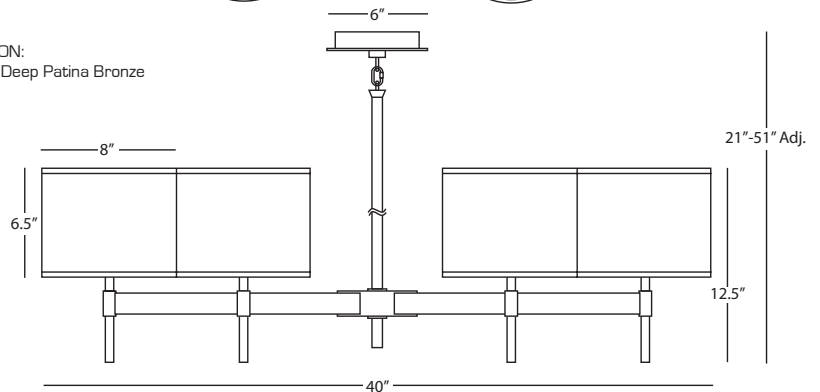
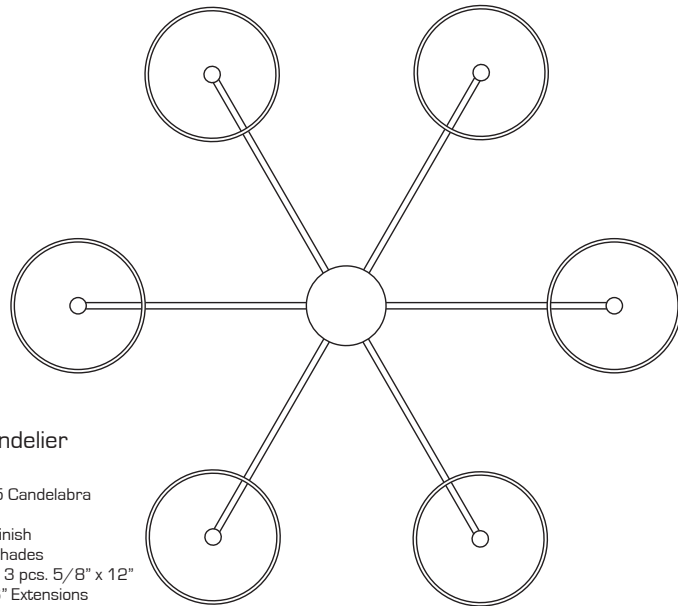



Z2156

# Echo

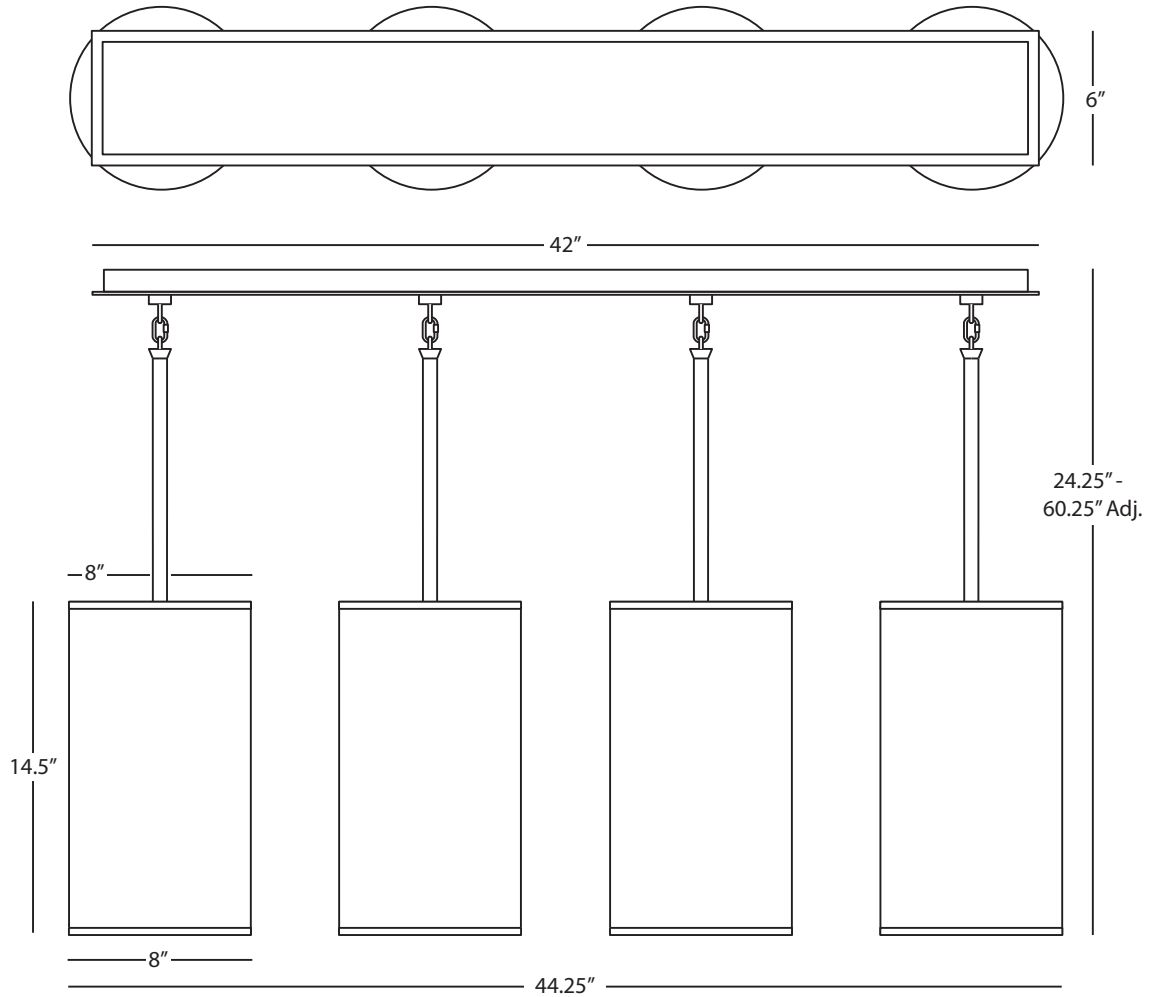

ECHO

## Z2156

### Linear Chandelier

4 - 60W Max.  
Bulb Type: B, Candelabra  
Direct Wire  
Deep Patina Bronze Finish  
Ascot White Fabric Shades  
Susp. Hardware: 12 pcs. 5/8" x 12" &  
4 pcs. 5/8" x 6" Extensions



W167



B167



K168



W168



B168



K169



B169

# Elena

ELENA

## W167 Small Pendant

1 - 100W Max.  
Bulb Type: A  
Direct Wire  
Pearl Dupioni Fabric Shade  
Susp. Hardware: 12 Ft. White Cord

SHADE OPTIONS:

**B167** Bone Dupioni  
**K167** Mushroom Dupioni

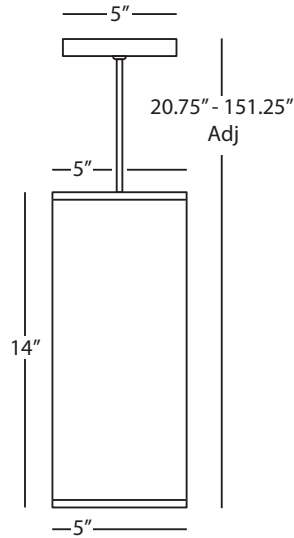

ELENA

## K168 Medium Pendant

1 - 100W Max.  
Bulb Type: A  
Direct Wire  
Mushroom Dupioni Fabric Shade w/  
Self-Fabric Bottom Diffuser  
Susp. Hardware: 12 Ft. White Cord

SHADE OPTIONS:

**B168** Bone Dupioni  
**W168** Pearl Dupioni

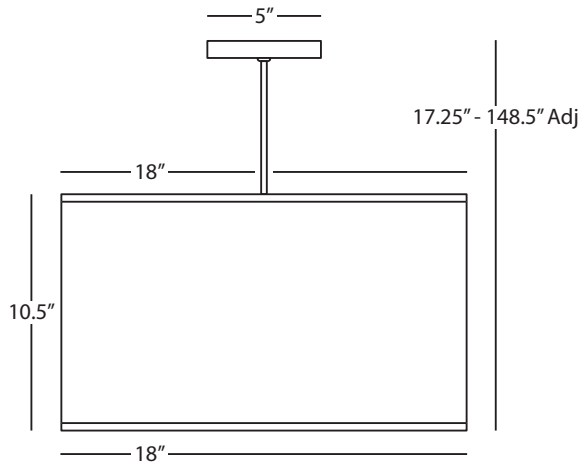

ELENA

## B169 Large Pendant

1 - 100W Max.  
Bulb Type: A  
Direct Wire  
Bone Dupioni Fabric Shade w/  
Self-Fabric Bottom Diffuser  
Susp. Hardware: 12 Ft. White  
Cord

SHADE OPTIONS:

**K169** Mushroom Dupioni  
**W169** Pearl Dupioni

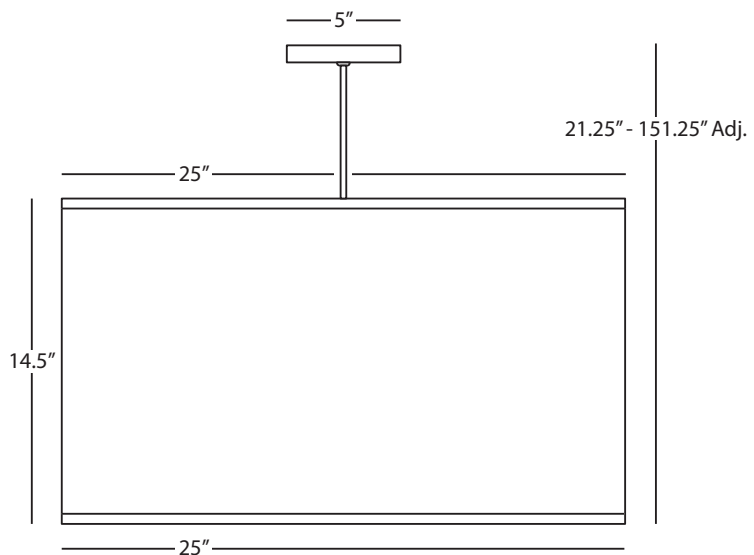



228



S228

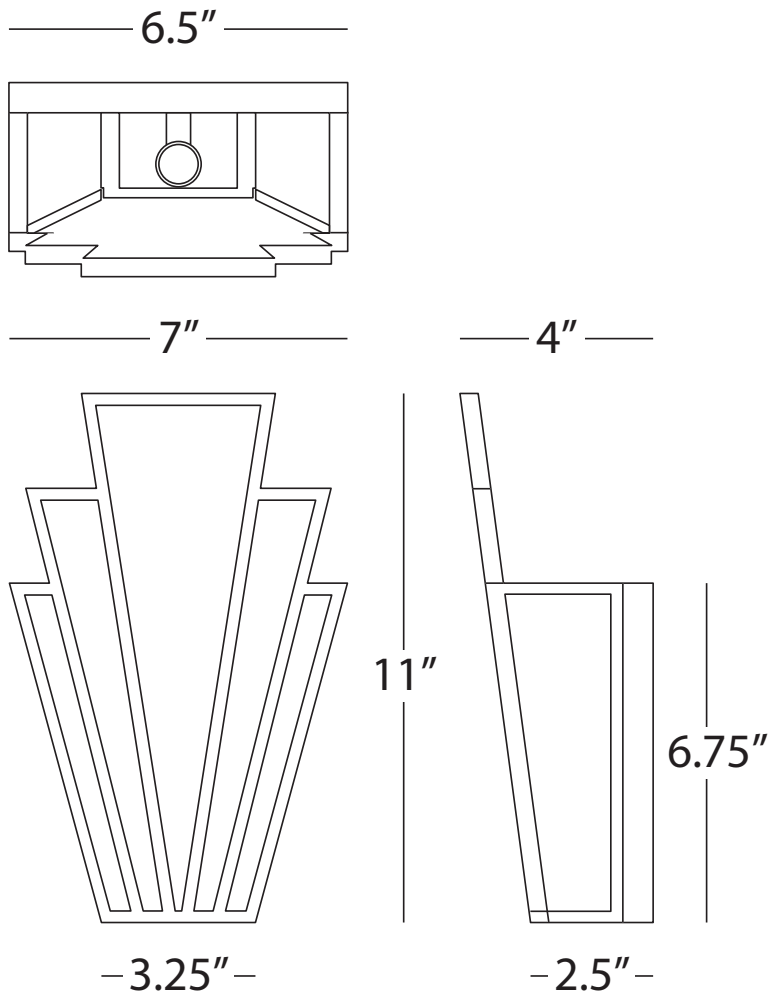

EMPIRE

**228**

Wall Sconce

1 - 60W Max.  
Bulb Type: B, Candelabra  
Direct Wire Only  
Modern Brass Finish  
White Glass Shade Panels  
ADA Compliant

FINISH OPTION:

**S228**    Antique Silver



S1549



# Enterprise

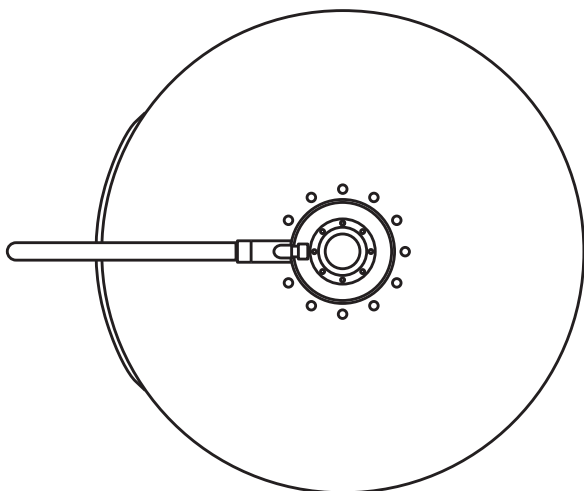

ENTERPRISE

## S1549

Task Lamp

1 - 100W Max.  
Bulb Type: A  
Switch: Hi-Lo Line Switch  
Polished Nickel Finish  
Adjustable Metal Shade

17.75" - 19.25" Adj.

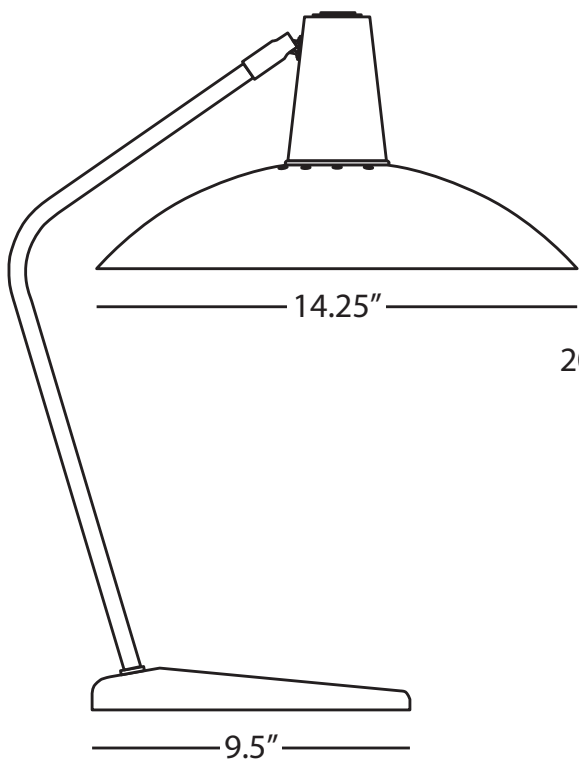

7.75"

14.25"

9.5"

20.25" - 21.5" Adj.

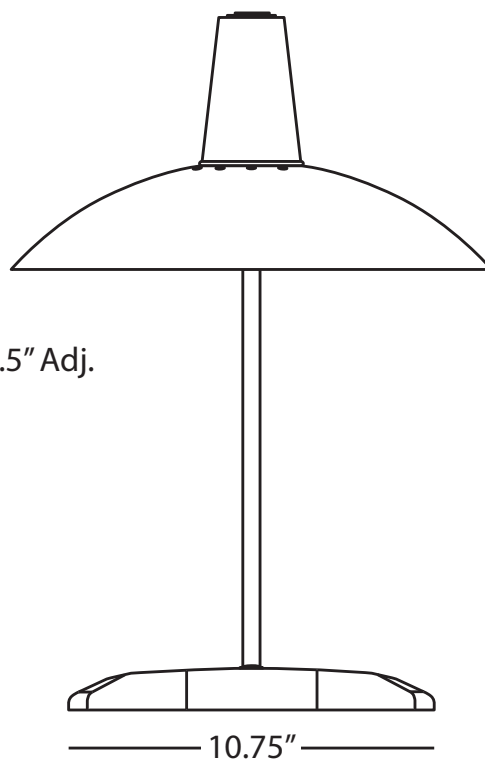

10.75"



S1212



1210

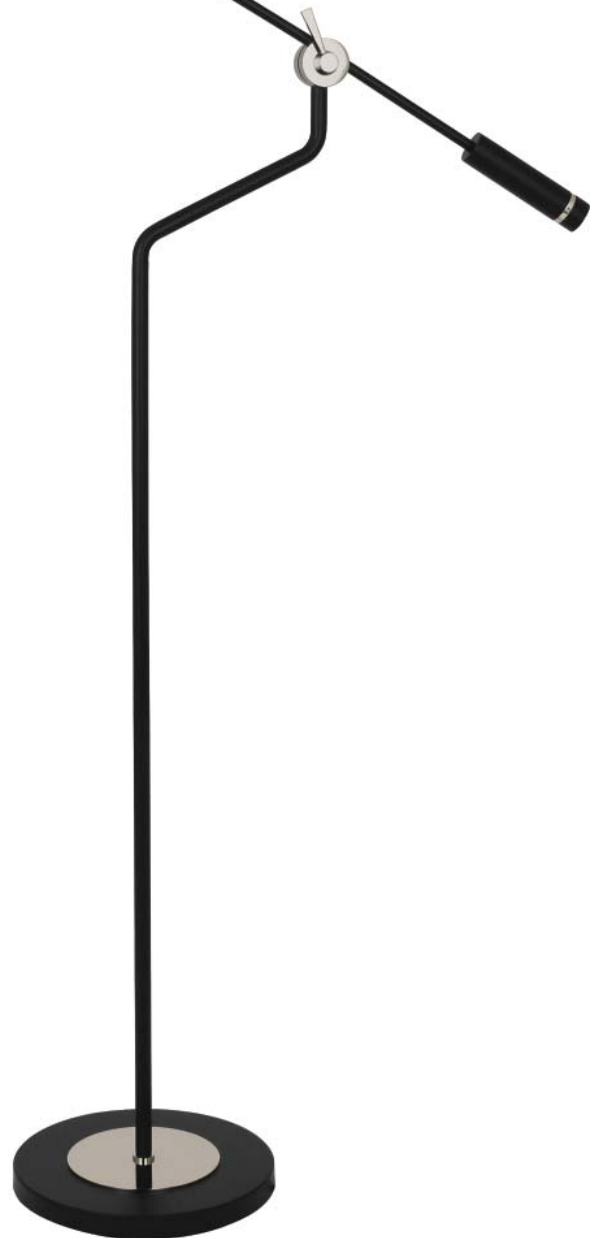

S1211

# Ferdinand

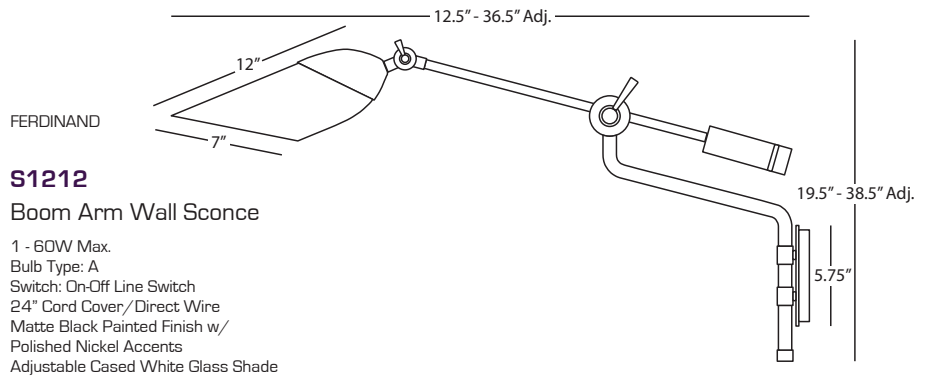

FERDINAND

## S1212 Boom Arm Wall Sconce

1 - 60W Max.  
Bulb Type: A  
Switch: On-Off Line Switch  
24" Cord Cover/Direct Wire  
Matte Black Painted Finish w/  
Polished Nickel Accents  
Adjustable Cased White Glass Shade

FINISH OPTION:  
**1212** Modern Brass Accents

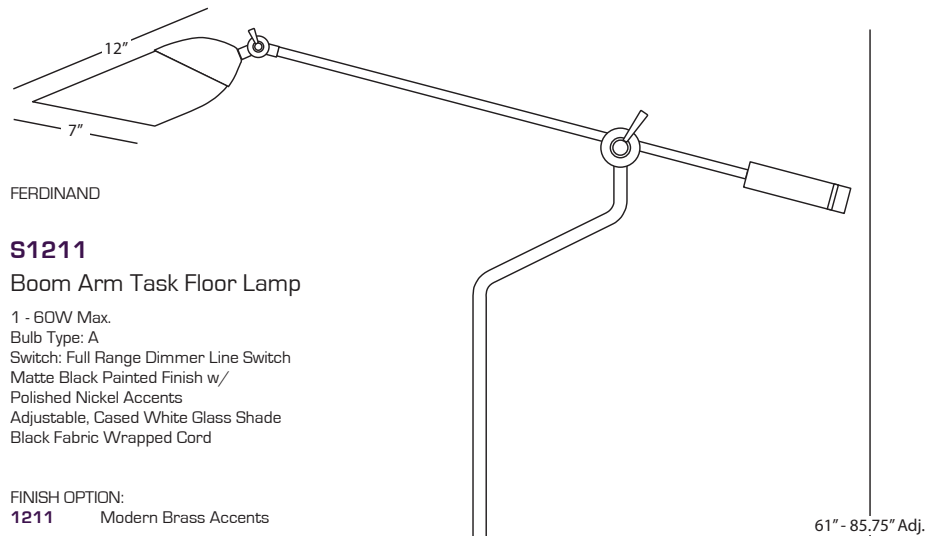

FERDINAND

## S1211 Boom Arm Task Floor Lamp

1 - 60W Max.  
Bulb Type: A  
Switch: Full Range Dimmer Line Switch  
Matte Black Painted Finish w/  
Polished Nickel Accents  
Adjustable, Cased White Glass Shade  
Black Fabric Wrapped Cord

FINISH OPTION:  
**1211** Modern Brass Accents

FERDINAND

## 1210 Boom Arm Task Table Lamp

1 - 60W Max.  
Bulb Type: A  
Switch: Full Range Dimmer Line Switch  
Matte Black Painted Finish w/  
Modern Brass Accents  
Adjustable, Cased White Glass Shade  
Black Fabric Wrapped Cord

FINISH OPTION:  
**S1210** Polished Nickel Accents

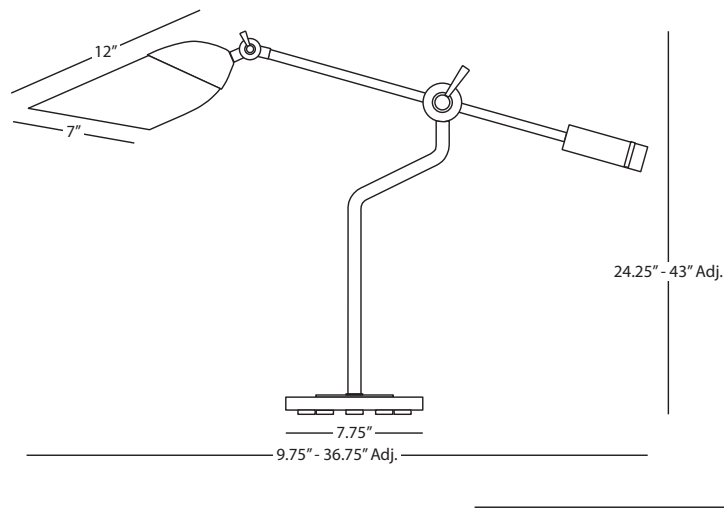

9.75" - 36.75" Adj.

24.25" - 43" Adj.

16.25" - 48.25" Adj.

61" - 85.75" Adj.



1514



1514B



1526



1518



1418

# Fineas

FINEAS

## 1526

### Backlit Accent Lamp

1 - 150W Max.  
 Bulb Type: A  
 Switch: Hi-Lo Dimming Line Switch  
 Alabaster Stone Base  
 Aged Brass Finish  
 Clear Seeded Glass Lens

Photographed with Historical Bulb  
 SOLD SEPARATELY  
 (HISO1 See Page 225)

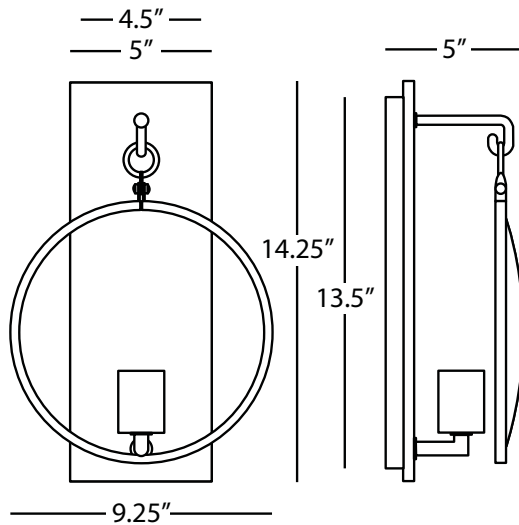
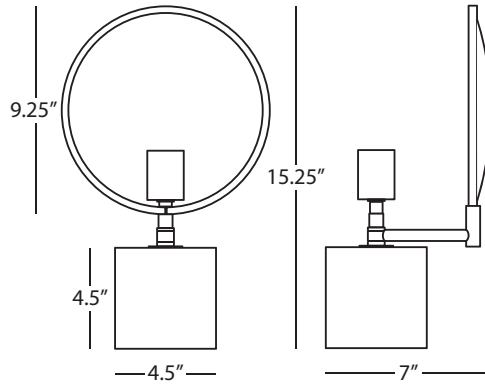

FINEAS

## 1418

### Wall Sconce

1 - 150W Max.  
 Bulb Type: A  
 On-Off Line Switch  
 24" Cord Cover/Direct Wire  
 Dark Antique Nickel Finish  
 Alabaster Stone Back Plate  
 Clear Seeded Glass Lens

Photographed with Historical Bulb  
 SOLD SEPARATELY  
 (HISO1 See Page 225)

FINISH OPTION:  
**1518** Aged Brass/Alabaster

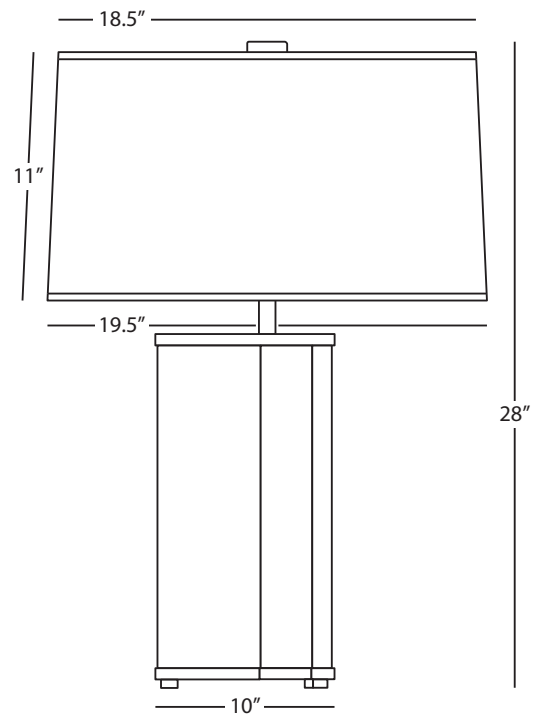
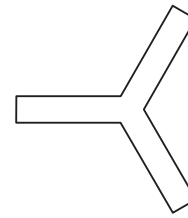

FINEAS

## 1514

### Table Lamp

1 - 150W Max.  
 Bulb Type: A  
 Hi-Lo Dimming  
 Alabaster Stone Panels  
 Aged Brass Accents  
 Fondine Fabric Shade

FINISH/SHADE OPTION:  
**1514B** Alabaster Stone/Aged Brass  
 Black Opaque Parchment  
 w/ White Lining



473B



S472

# Fineas

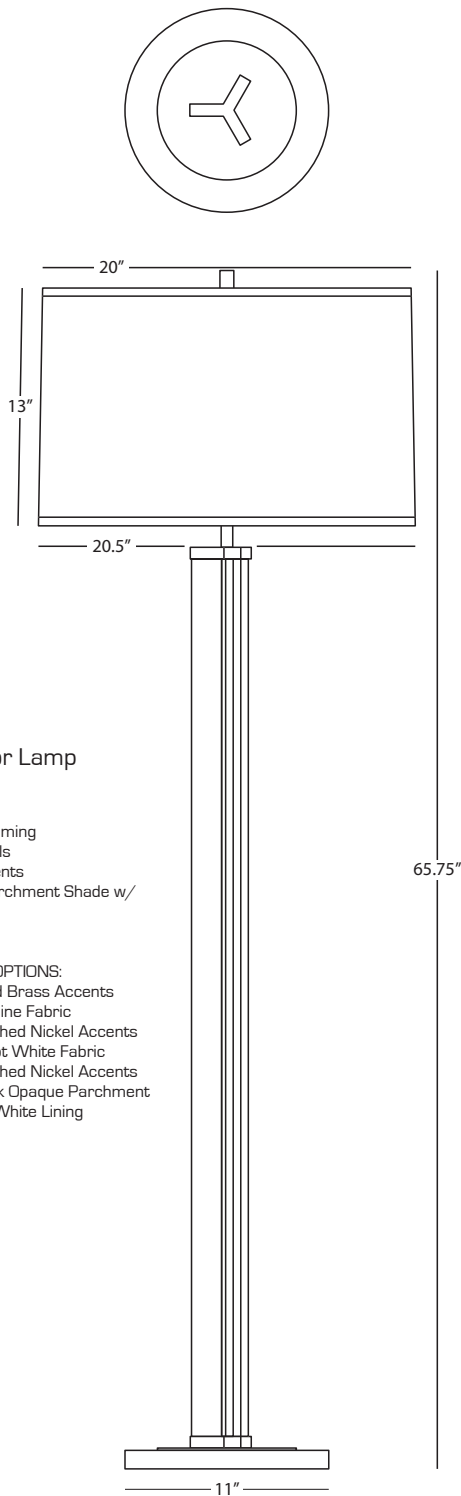

FINEAS

## 473B

### Column Floor Lamp

1 - 150W Max.  
 Bulb Type: A  
 Switch: Hi-Lo Dimming  
 Clear Glass Panels  
 Aged Brass Accents  
 Black Opaque Parchment Shade w/  
 White Lining

#### FINISH/SHADE OPTIONS:

- 473** Aged Brass Accents  
Fondine Fabric
- S473** Polished Nickel Accents  
Ascot White Fabric
- S473B** Polished Nickel Accents  
Black Opaque Parchment  
w/ White Lining

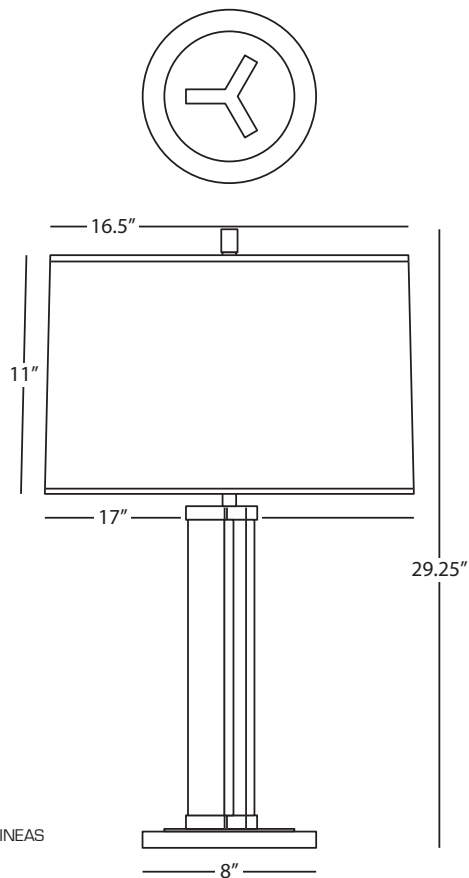

FINEAS

## S472

### Column Table Lamp

1 - 150W Max.  
 Bulb Type: A  
 Switch: Hi-Lo Dimming  
 Clear Glass Panels  
 Polished Nickel Accents  
 Ascot White Fabric Shade

#### FINISH/SHADE OPTIONS:

- 472** Aged Brass Accents  
Fondine Fabric
- 472B** Aged Brass Accents  
Black Opaque Parchment  
w/ White Lining
- S472B** Polished Nickel Accents  
Black Opaque Parchment  
w/ White Lining



1420



D1420



# Fineas

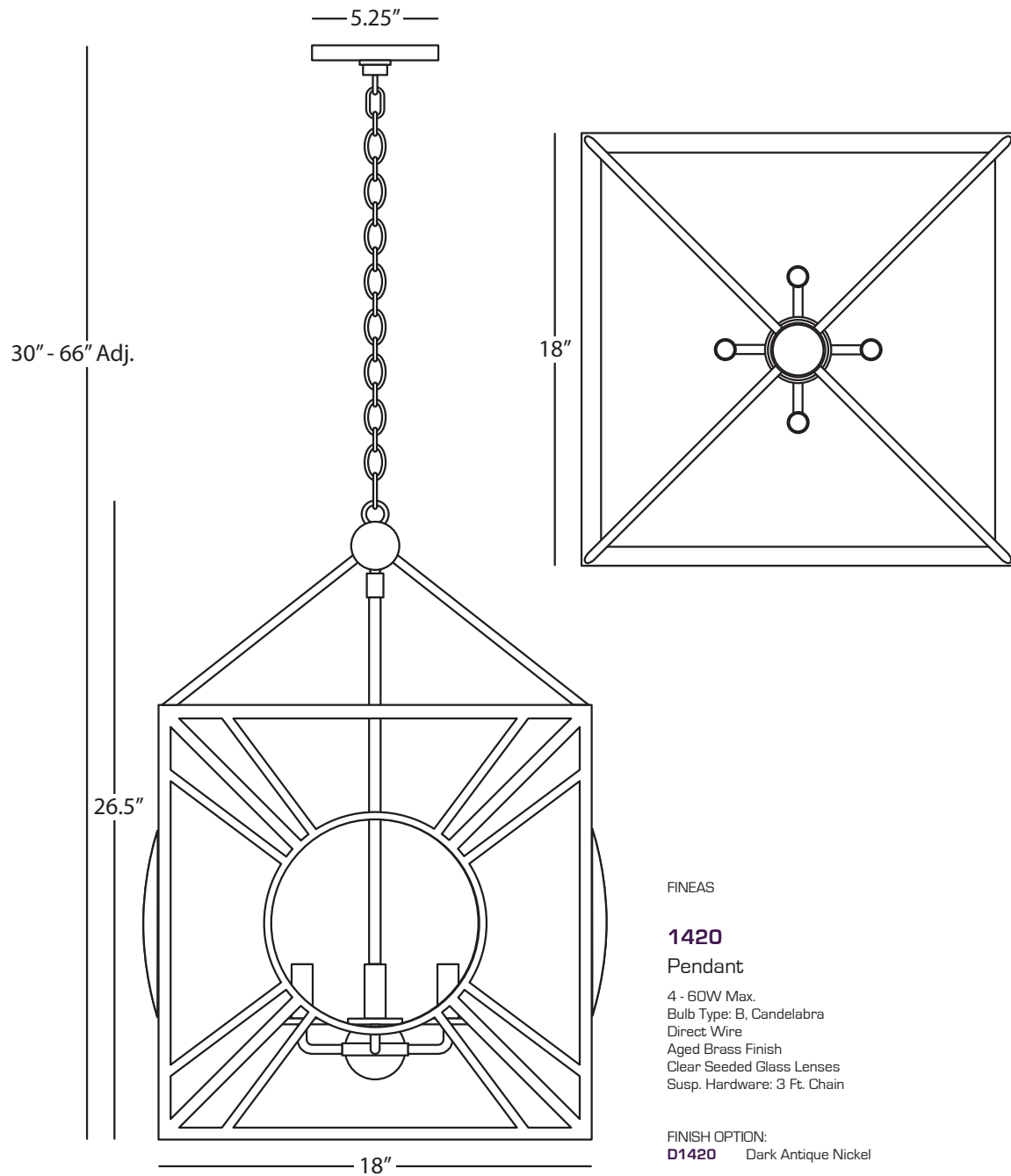

FINEAS

## 1420 Pendant

4 - 60W Max.  
Bulb Type: B, Candelabra  
Direct Wire  
Aged Brass Finish  
Clear Seeded Glass Lenses  
Susp. Hardware: 3 Ft. Chain

FINISH OPTION:  
**D1420** Dark Antique Nickel



1041

# Fletcher

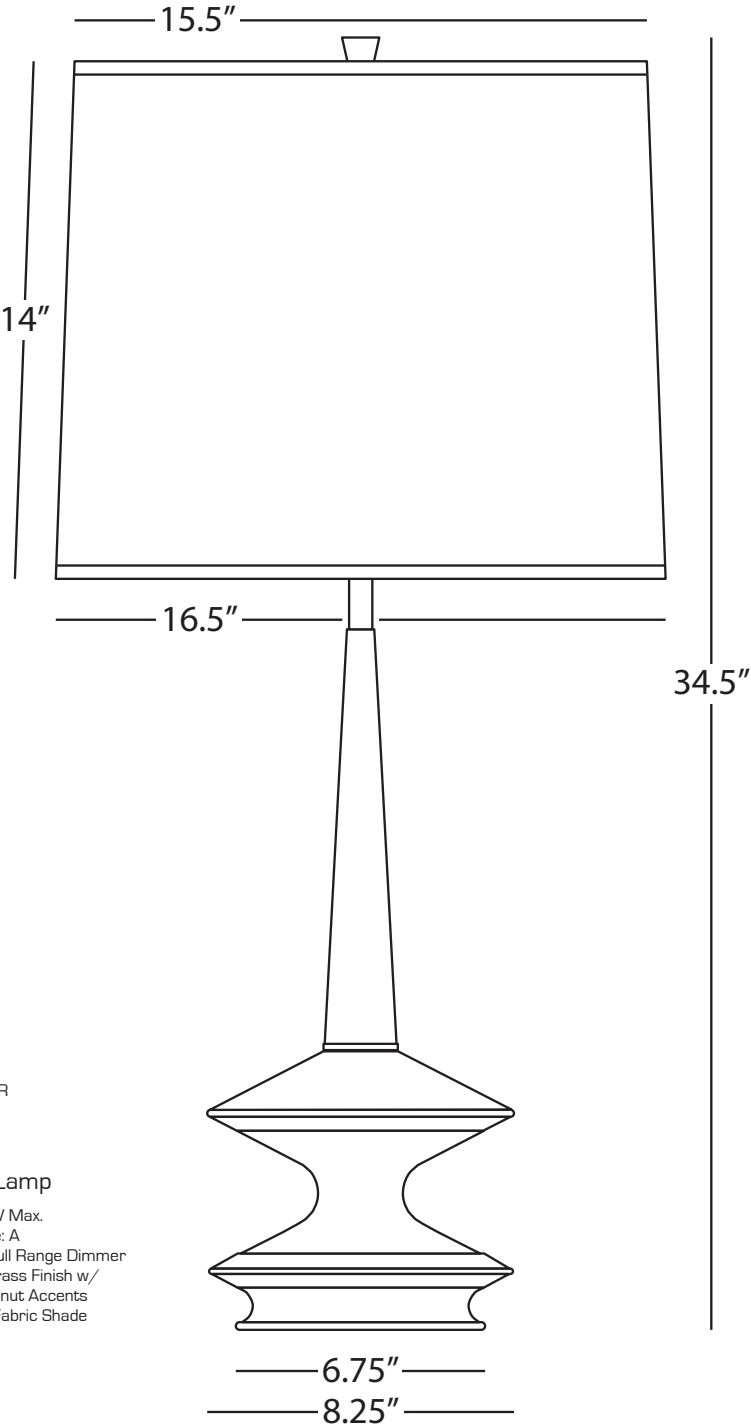

FLETCHER

**1041**  
Table Lamp

1 - 150W Max.  
Bulb Type: A  
Switch: Full Range Dimmer  
Warm Brass Finish w/  
Dark Walnut Accents  
Fondine Fabric Shade



9938COP



9938KRST



9939KCOP



9939XRST

# Foundry

FOUNDRY

## 9938COP

### Horizontally Gifted Pot

1 - 150W Max.  
 Bulb Type: A  
 Switch: 3-Way  
 Copper Finish  
 Natural Fabric Shade

FINISH/SHADE OPTIONS:

- 9938KCOP** Copper
- Brussels Linen Natural
- 9938KRST** Antique Rust
- Brussels Linen Natural
- 9938XRST** Antique Rust
- Translucent Flax
- Parchment

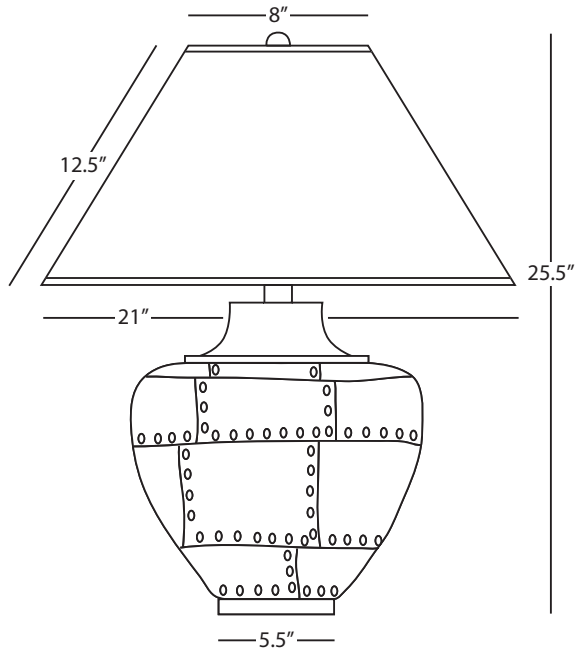

FOUNDRY

## 9939XRST

### Vertically Gifted Pot

1 - 150W Max.  
 Bulb Type: A  
 Switch: 3-Way  
 Antique Rust Finish  
 Translucent Flax Parchment Shade

FINISH/SHADE OPTIONS:

- 9939KRST** Antique Rust
- Brussels Linen Natural
- 9939COP** Copper
- Natural Fabric
- 9939BCOP** Copper
- Black Parchment
- 9939KCOP** Copper
- Brussels Linen Natural

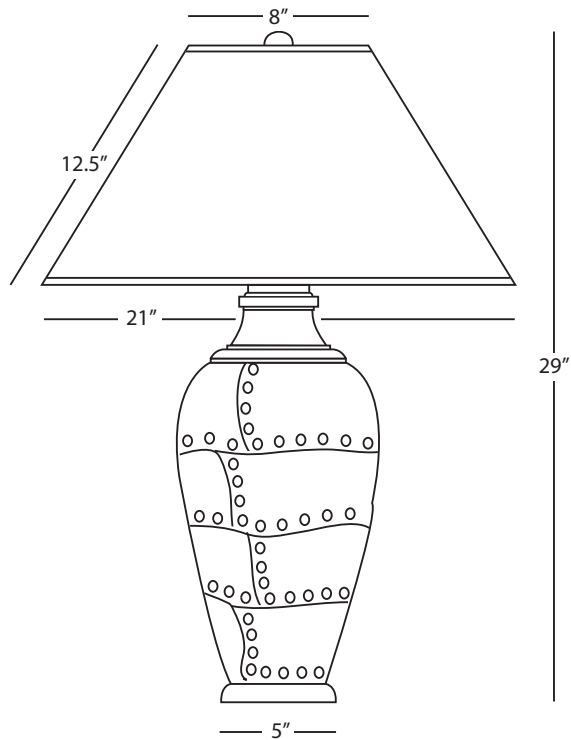

# | Franklin

---



# Franklin

---

[Click photo above to watch Franklin Table Lamp Video](#)

Inspired by the natural geometry found in turtle shells, the Franklin collection was created to be the perfect accent for your space. Available in a beautiful array of gloss and matte colors, Franklin adds visual interest and provides a pop of color or a stylish contrast.

---

# | Franklin

---





# Franklin

[Click photo above to watch Franklin Accent Lamp Video](#)

Inspired by the natural geometry found in turtle shells, the Franklin collection was created to be the perfect accent for your space. Available in a beautiful array of gloss and matte colors, Franklin adds visual interest and provides a pop of color or a stylish contrast.

# Franklin



ST02



MB01



BB02



CM02



PC01



AP02



MCR02



MLY01



MCL02

# Franklin

FRANKLIN

## ST02 Accent Lamp

1 - 60W Max.  
Bulb Type: A  
Switch: Full Range Dimmer Line Switch  
Smoky Taupe Glazed Ceramic  
Polished Nickel Accents  
Oyster Linen Shade w/  
Self-Fabric Top Diffuser

See Page 230 for Color Options

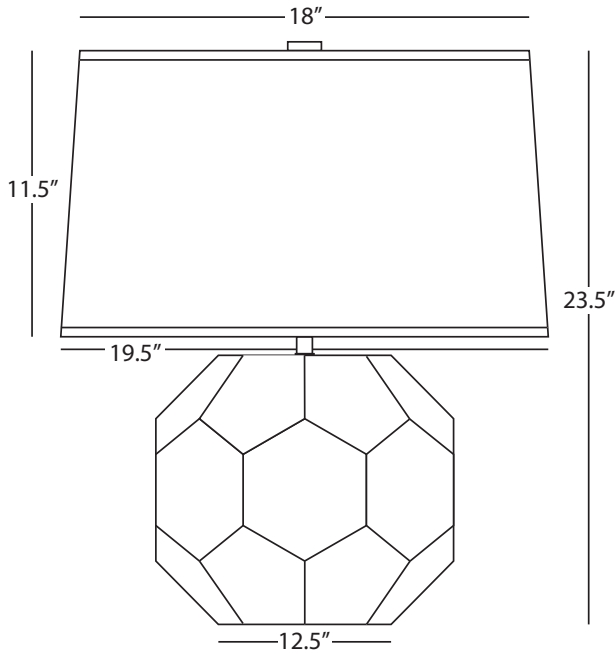
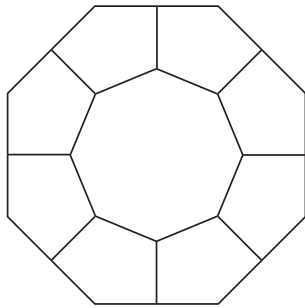
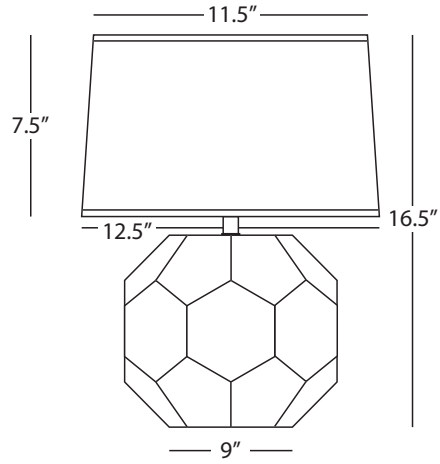
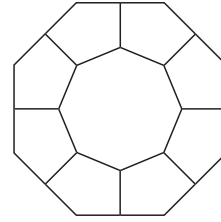

FRANKLIN

## MB01 Table Lamp

1 - 150W Max.  
Bulb Type: A  
Switch: Full Range Dimmer  
Midnight Blue Glazed Ceramic  
Polished Nickel Accents  
Oyster Linen Shade w/  
Self-Fabric Top Diffuser

See Page 230 for Color Options



MR981



PM981



CI981



SP981



TE981

# Fusion

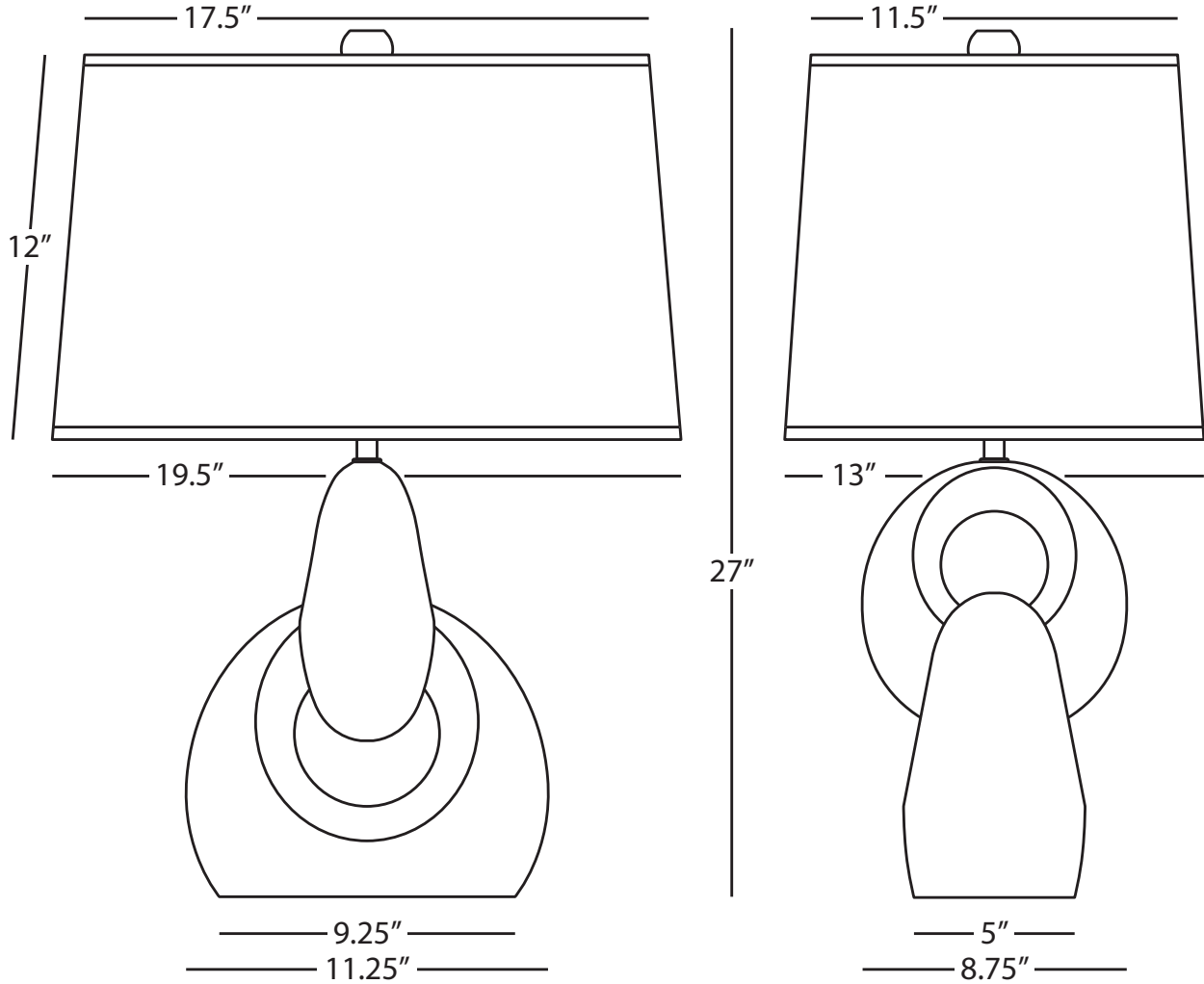

FUSION

**C1981**

Table Lamp

- 1 - 150W Max.
- Bulb Type: A
- Switch: Full Range Dimmer
- Citron Glazed Ceramic
- Polished Nickel Accents
- Oval, Oyster Linen Shade

See Page 231 for Color Options



S373



373

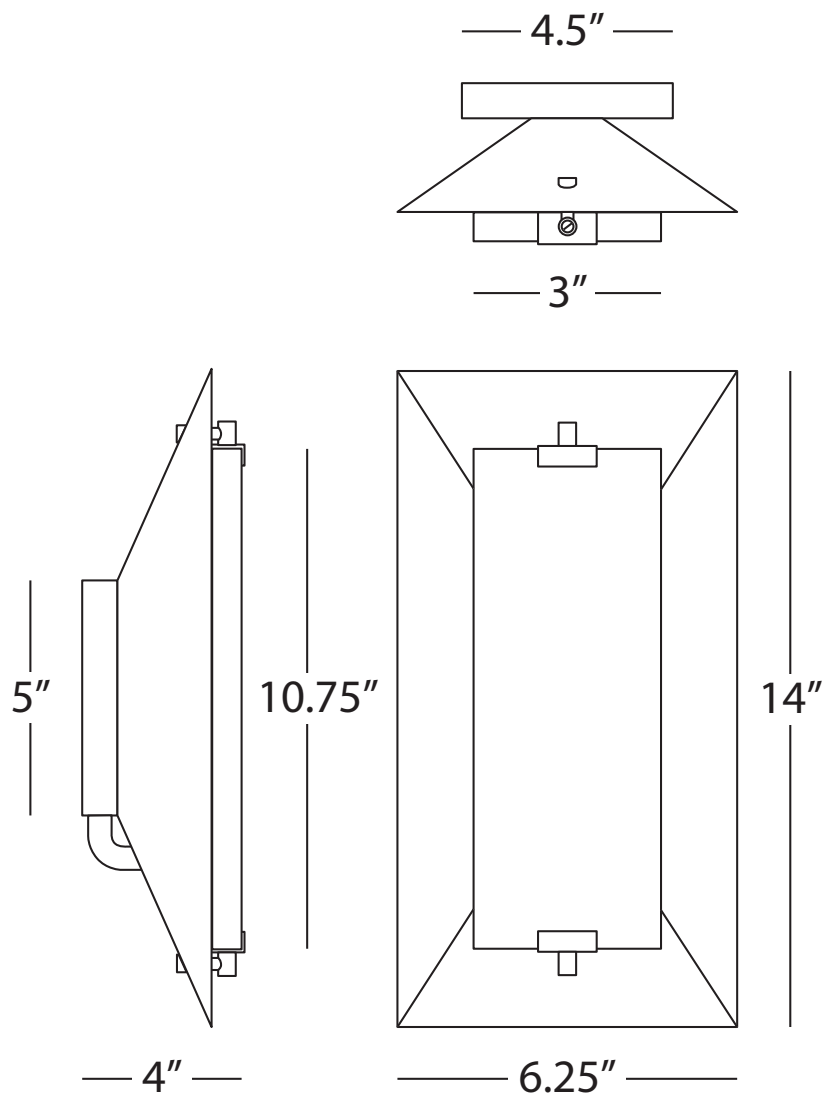

GEMMA

### 373

#### Wall Sconce

1 - 60W Max.  
Bulb Type: B, Candelabra  
Direct Wire Only  
Modern Brass Finish w/  
Rock Crystal Diffuser  
ADA Compliant

FINISH OPTION:

**S373** Polished Nickel



W3323



# Glass Harriet

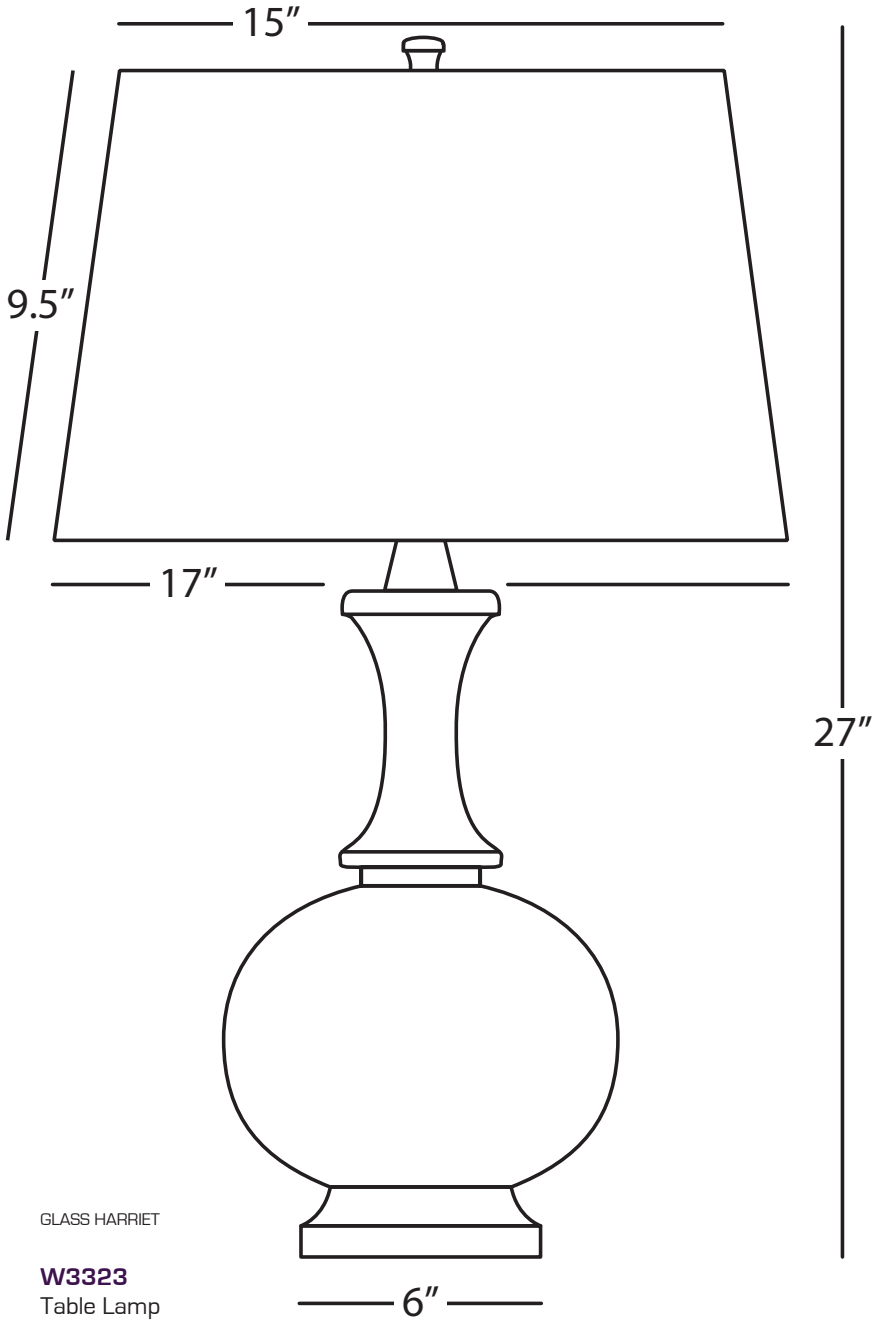

GLASS HARRIET

**W3323**  
Table Lamp

1 - 150W Max.  
Bulb Type: A  
Switch: Full Range Dimmer  
White Glass w/ Polished Nickel Accents  
Off-White Cotton Shade w/  
Rolled Edge Hem



Z1440



1440

# Gloria

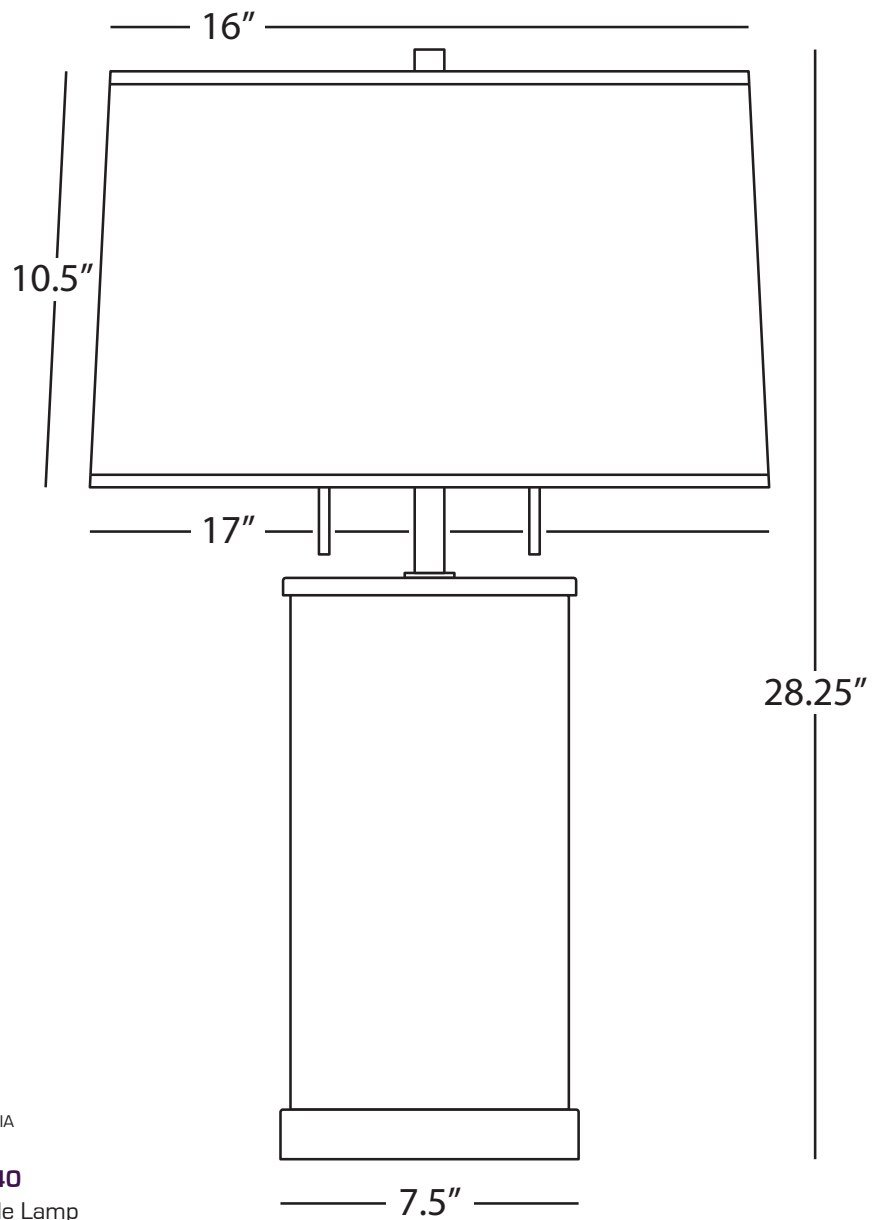

GLORIA

**1440**

Table Lamp

2 - 150W Max.

Bulb Type: A

Switch: Hi-Lo Pull Chains

Wavy Glass Body w/

Modern Brass Accents

Oyster Linen Shade

FINISH OPTION:

**Z1440** Deep Patina Bronze



418



S416



415

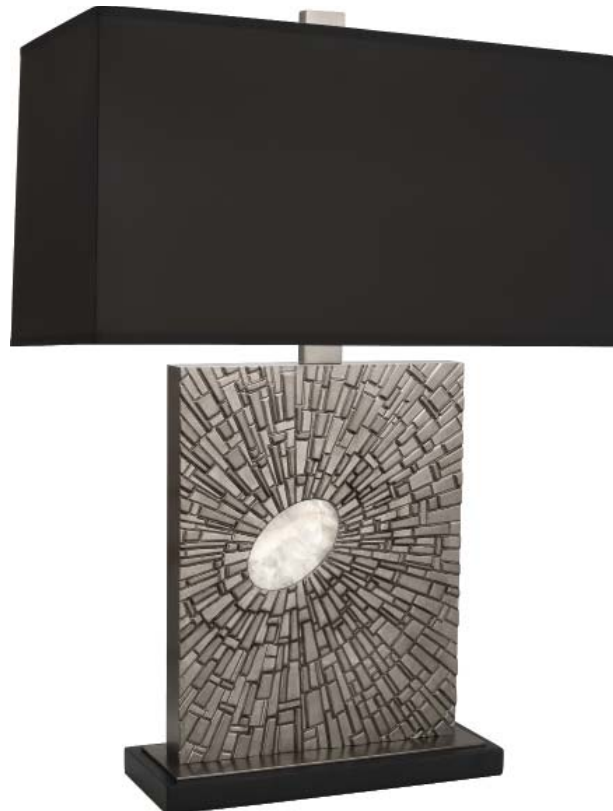

S415B

# Goliath

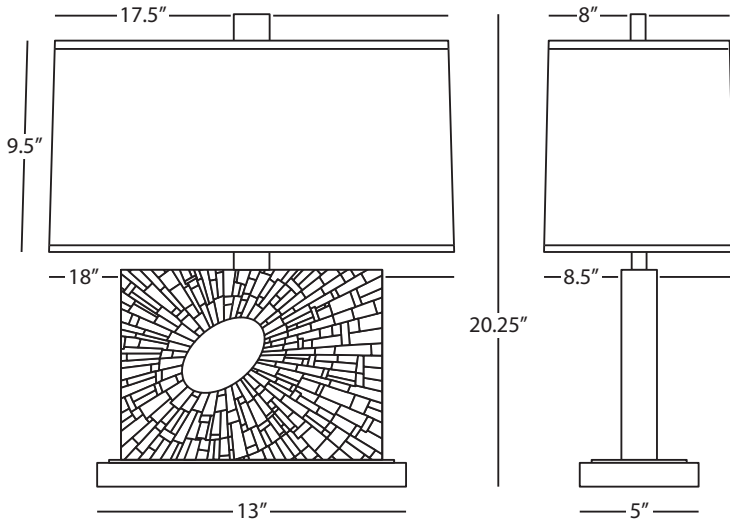

GOLIATH

## S416

### Accent Lamp

1 - 100W Max.  
 Bulb Type: A  
 Switch: Full Range Dimmer  
 Antiqued Polished Nickel Finish  
 White Rock Crystal Accent  
 Rectangular Pearl Dupioni Silk Shade

#### FINISH/SHADE OPTIONS:

- 416** Antiqued Modern Brass/Pearl Dupioni Silk
- 416B** Antiqued Modern Brass/Black Opaque  
Parchment Shade w/ Matte Gold Lining
- S416B** Antiqued Polished Nickel/Black Opaque  
Parchment Shade w/ Matte Silver Lining

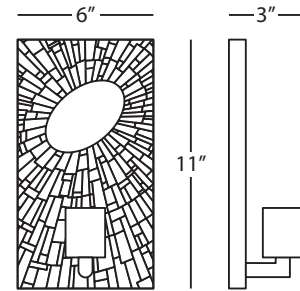

GOLIATH

## 418

### Wall Sconce

1 - 60W Max.  
 Bulb Type: T, Medium Base  
 Switch: On-Off Line Switch  
 24" Cord Cover/Direct Wire  
 Antiqued Modern Brass Finish  
 White Rock Crystal Accent  
 ADA Compliant

Photographed with Historical Bulb  
 SOLD SEPARATELY  
 (HISO1 See Page 225)

#### FINISH OPTION:

- S418** Antiqued Polished Nickel

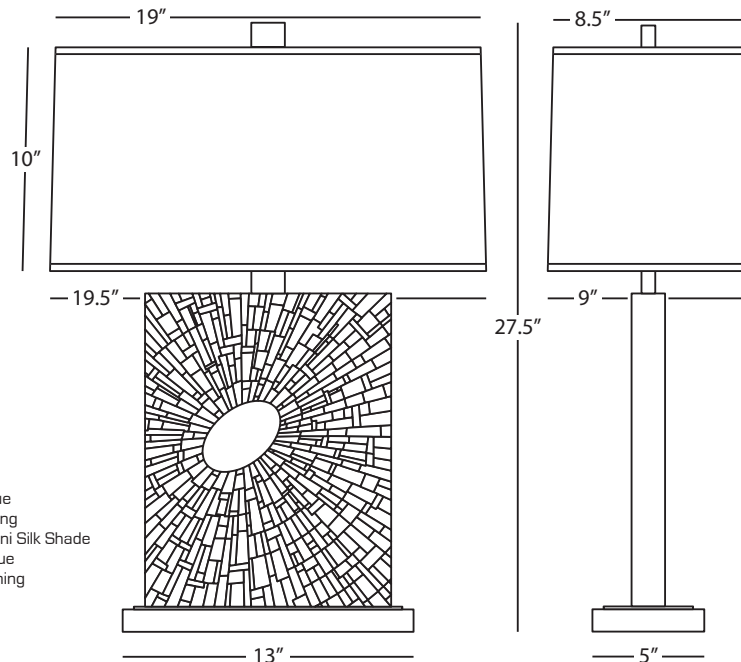

GOLIATH

## 415

### Table Lamp

1 - 100W Max.  
 Bulb Type: A  
 Switch: Full Range Dimmer  
 Antiqued Modern Brass Finish  
 White Rock Crystal Accent  
 Rectangular Pearl Dupioni Silk Shade

#### FINISH/SHADE OPTIONS:

- 415B** Antiqued Modern Brass/Black Opaque  
Parchment Shade w/ Matte Gold Lining
- S415** Antiqued Polished Nickel/Pearl Dupioni Silk Shade
- S415B** Antiqued Polished Nickel/Black Opaque  
Parchment Shade w/ Matte Silver Lining



3367



3368

# Gossamer

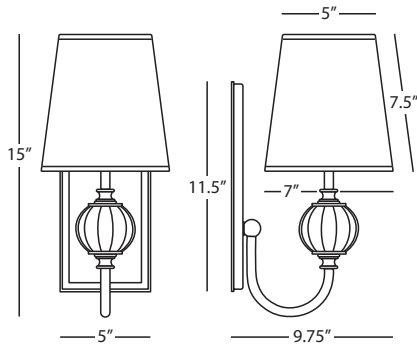

GOSSAMER

## 3368 Wall Sconce

1 - 100W Max.  
Bulb Type: A  
Direct Wire Only  
Weathered Brass Finish w/  
Lead Crystal & Antique Mirror Accents  
Oyster Gray Silk Shade w/  
Gold Foil Lining

GOSSAMER

## 3367 6-Light Chandelier

6 - 60W Max.  
Bulb Type: B, Candelabra  
Direct Wire  
Weathered Brass Finish w/ Distressed  
Mercury Glass & Lead Crystal Accents  
Oyster Gray Silk Shade w/  
Gold Foil Lining  
Susp. Hardware: 3 pcs. 5/8" x 12" &  
1 pc. 5/8" x 6" Extensions

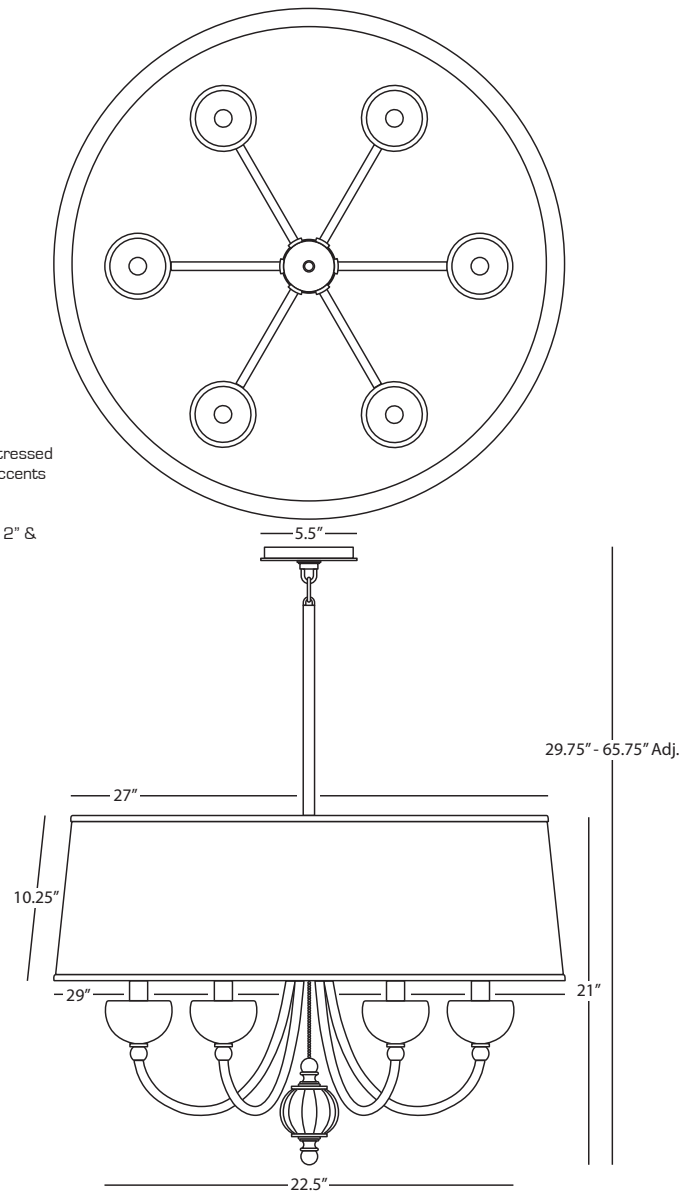



419



S419



# Gravity

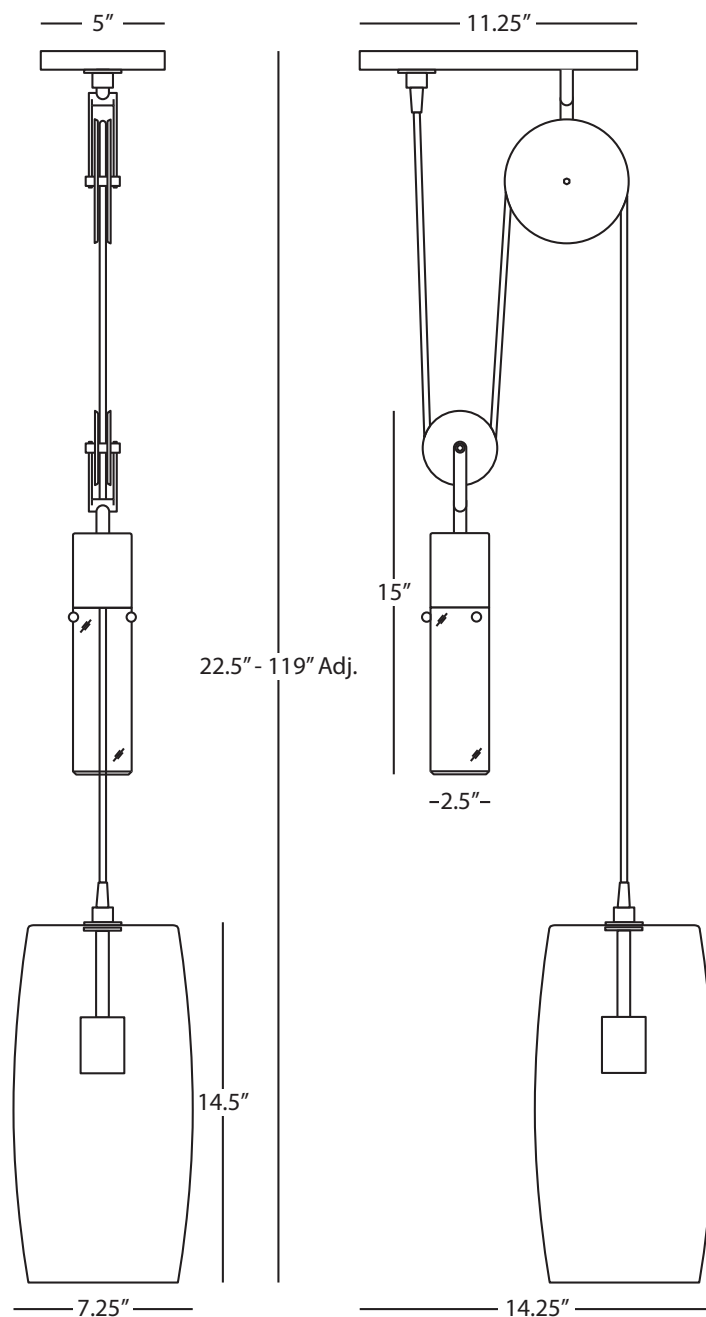

GRAVITY

## 419

### Counterweight Pendant

1 - 100W Max.  
Bulb Type: A  
Direct Wire  
Modern Brass Finish w/  
Clear Crystal Counterweight  
Clear Glass Shade  
Susp. Hardware: 12 Ft. Black Fabric Wrapped Cord

Photographed with Historical Bulb  
SOLD SEPARATELY  
(HIS01 See Page 225)

FINISH OPTION:

**S419** Polished Nickel



C1324



1324



B1325

# Halo

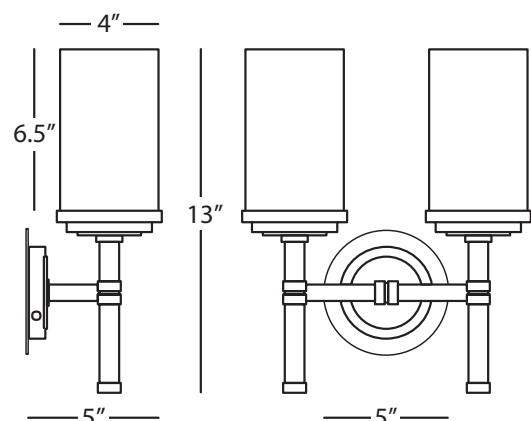
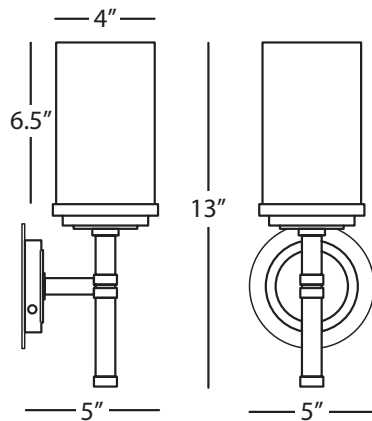
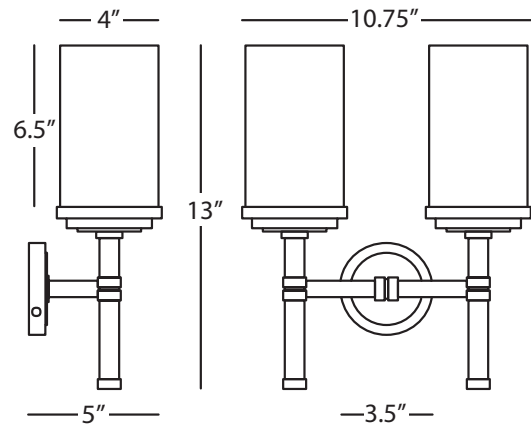
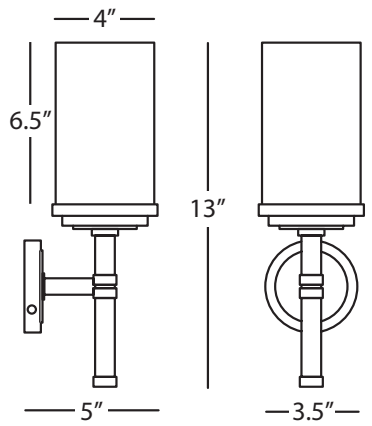

Shown with Optional Junction Box Cover Plate

Shown with Optional Junction Box Cover Plate

HALO

**1324**  
Single Sconce

1 - 60W Max.  
Bulb Type: A  
Direct Wire Only  
Brushed Brass Finish w/  
Polished Brass Accents  
Cased White Glass Shade

FINISH OPTIONS:

- B1324** Brushed Nickel w/  
Polished Nickel Accents
- C1324** Brushed Chrome w/  
Polished Chrome Accents

\*Metal Junction Box Cover Plate in Matching Finish Included

HALO

**B1325**  
Double Sconce

2 - 60W Max.  
Bulb Type: A  
Direct Wire Only  
Brushed Nickel Finish w/  
Polished Nickel Accents  
Cased White Glass Shades

FINISH OPTIONS:

- 1325** Brushed Brass w/  
Polished Brass Accents
- C1325** Brushed Chrome w/  
Polished Chrome Accents

\*Metal Junction Box Cover Plate in Matching Finish Included



AM990



AP990



EG990



ST995



MB995

HARVEY

**AM990**

Accent Lamp

1 - 60W Max.  
 Bulb Type: G16.5, Candelabra  
 Switch: Hi-Lo Line Switch  
 Amethyst Glazed Ceramic  
 Lucite Base  
 Oyster Linen Shade w/  
 Self-Fabric Top Diffuser

See Page 232 for Color Options

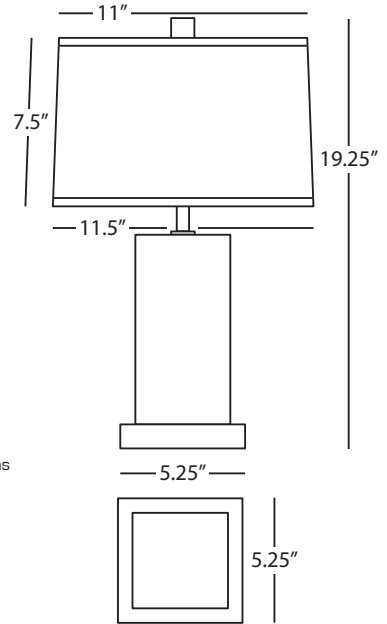

HARVEY

**MB995**

Table Lamp

1 - 150W Max.  
 Bulb Type: A  
 Switch: Hi-Lo Dimming  
 Midnight Blue Glazed Ceramic  
 Lucite Base  
 Oyster Linen Shade

See Page 232 for Color Options

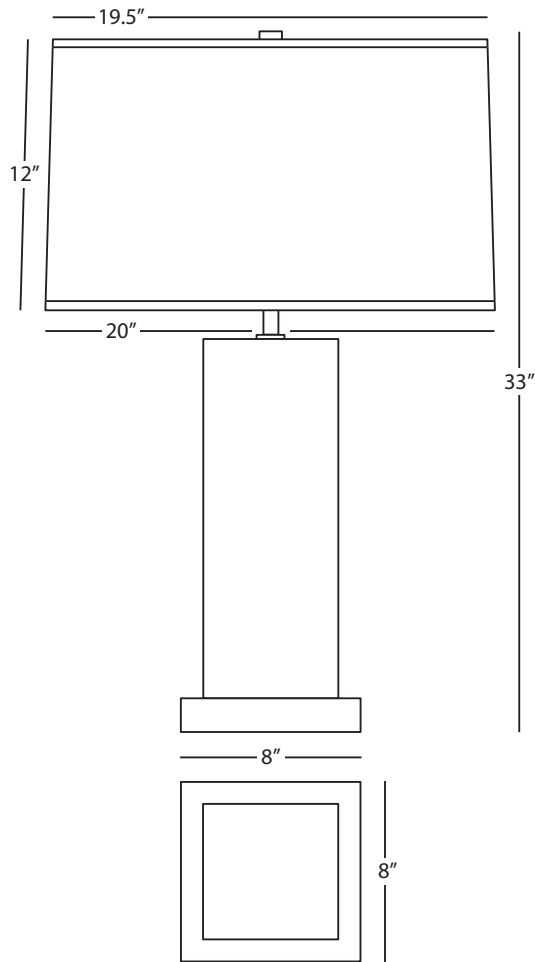



833



832



832X



987



831

# Helena

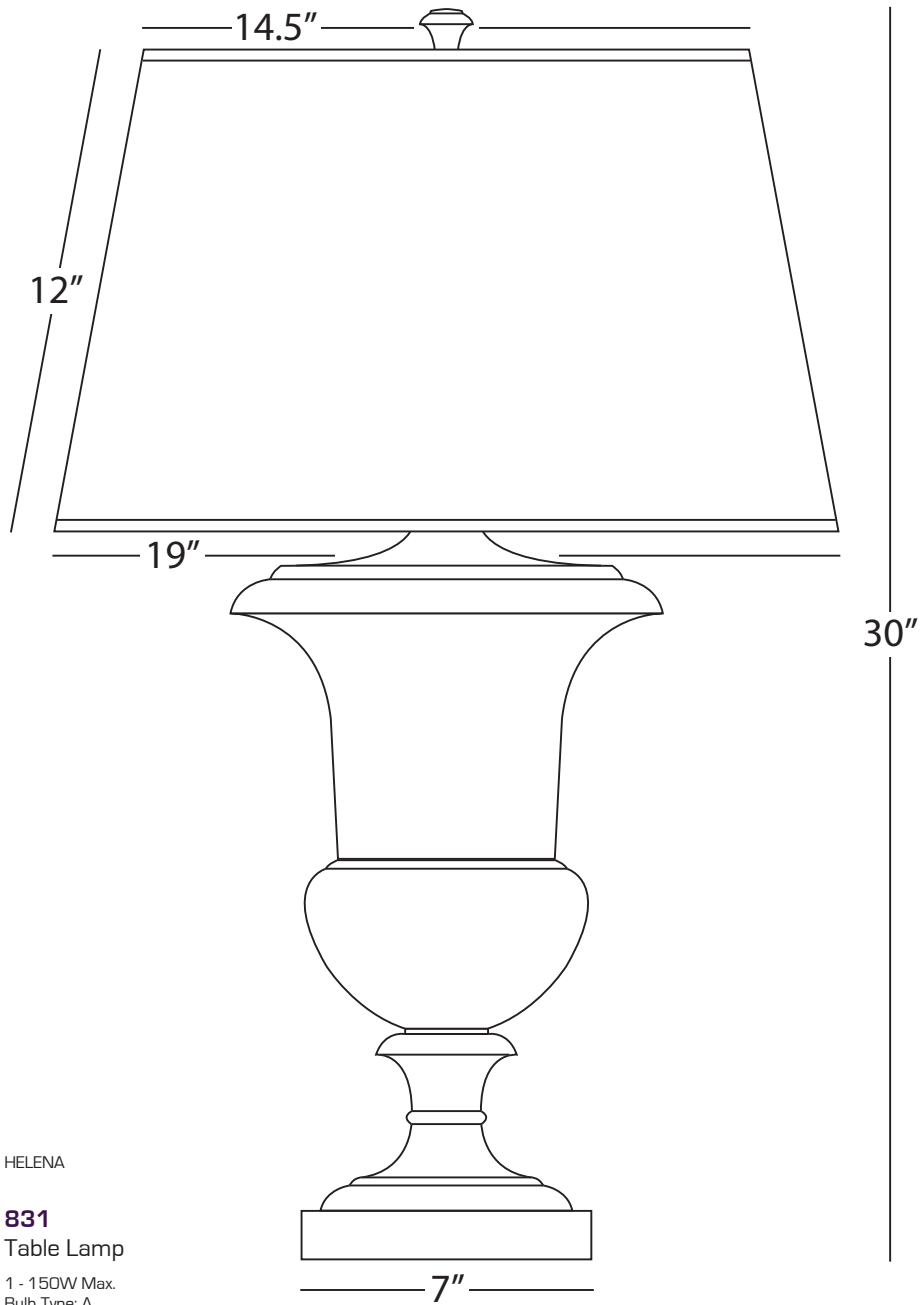

HELENA

**831**  
Table Lamp

1 - 150W Max.  
Bulb Type: A  
Switch: 3-Way  
Matte White Painted Finish over Poly Resin  
White Brussels Linen Shade

FINISH/SHADE OPTIONS:

- 832** Faux Limestone Painted Finish  
Oyster Linen Shade
- 832X** Faux Limestone Painted Finish  
Taupe Painted Opaque Parchment Shade
- 833** Faux Concrete Painted Finish  
Translucent White Monte Blanc Parchment Shade
- 987** Matte Black Painted Finish  
Matte Black Painted Opaque Parchment Shade



WZ450



WZ46G



JV46R



# Helena Al Fresco

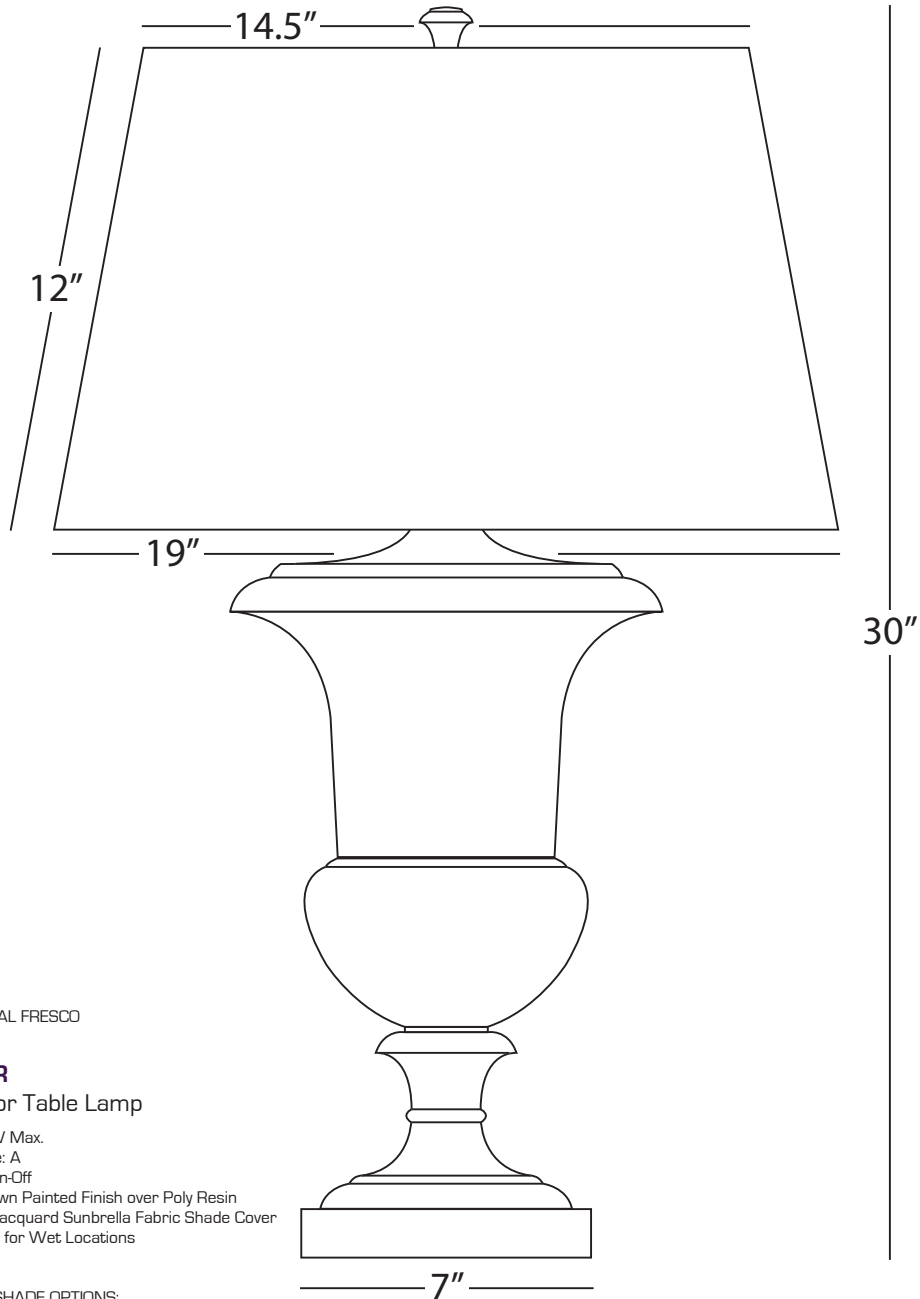

HELENA AL FRESCO

## JV46R

### Outdoor Table Lamp

1 - 100W Max.  
Bulb Type: A  
Switch: On-Off  
Java Brown Painted Finish over Poly Resin  
Orange Jacquard Sunbrella Fabric Shade Cover  
UL Rated for Wet Locations

#### FINISH/SHADE OPTIONS:

<b>JV46G</b>	Java Brown Gray Jacquard Sunbrella Fabric
<b>JV450</b>	Java Brown White Sunbrella Fabric
<b>WZ46G</b>	Weathered Zinc Gray Jacquard Sunbrella Fabric
<b>WZ46R</b>	Weathered Zinc Orange Jacquard Sunbrella Fabric
<b>WZ450</b>	Weathered Zinc White Sunbrella Fabric



Z853



S852

# Heron

HERON

## S852

### Task Table Lamp

1 - 5W Max.  
Bulb Type: Solid State LED (Non-Replaceable)  
LED Color Temp: 2900K, CRI: 90  
Lumen Output: 540  
Switch: On-Off Touch  
Polished Nickel Finish  
Metal Shade  
Clear Glass Diffuser  
USB Port on Base

FINISH OPTION:

**Z852** Deep Patina Bronze

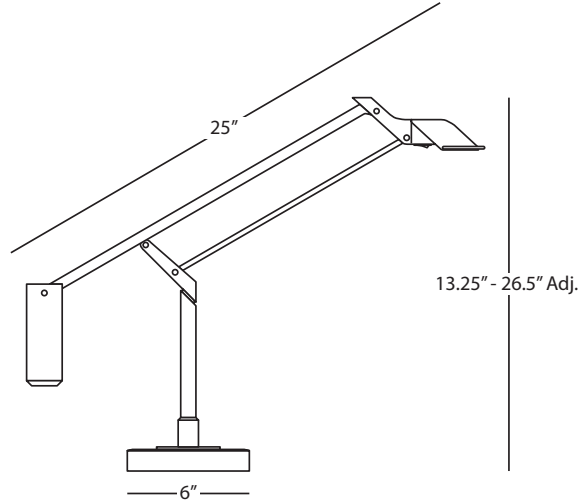

HERON

## Z853

### Task Floor Lamp

1 - 5W Max.  
Bulb Type: Solid State LED (Non-Replaceable)  
LED Color Temp: 2900K, CRI: 90  
Lumen Output: 540  
Switch: On-Off Touch  
Deep Patina Bronze Finish  
Metal Shade  
Clear Glass Diffuser

FINISH OPTION:

**S853** Polished Nickel

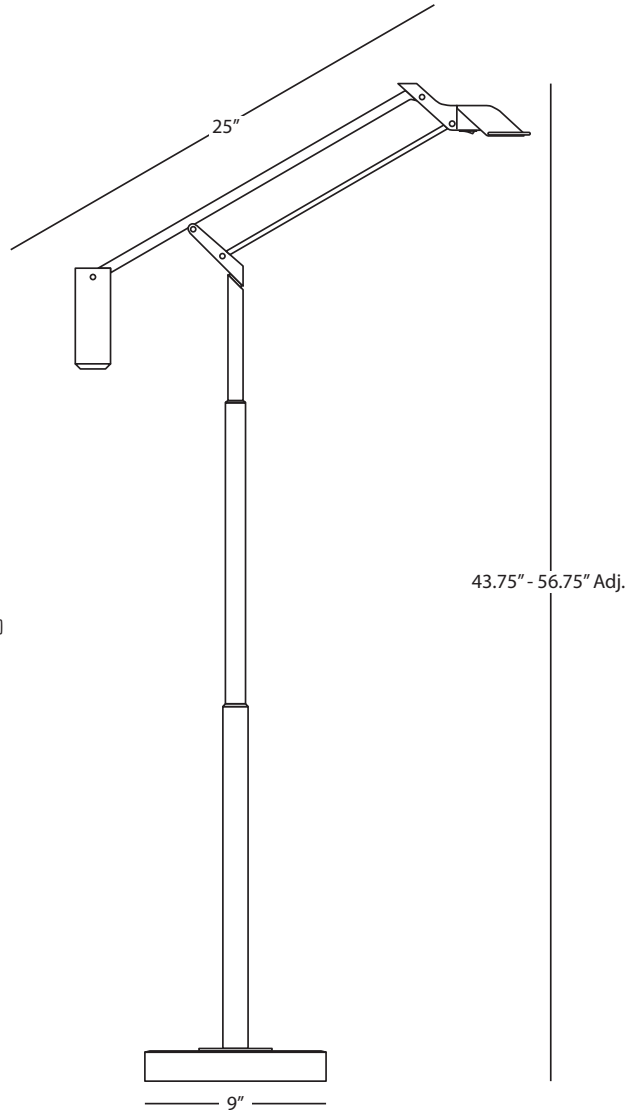

# Horizon



# Horizon

---

[Click photo above to watch Horizon Table Lamp Video](#)

A modern spin on classic beehive glass, the Horizon collection features charming contours that have sculptural appeal while remaining airy and light. Available in both clear and smoke gray glass, Horizon is an ideal choice for making a beautiful statement in your home.

---

# Horizon

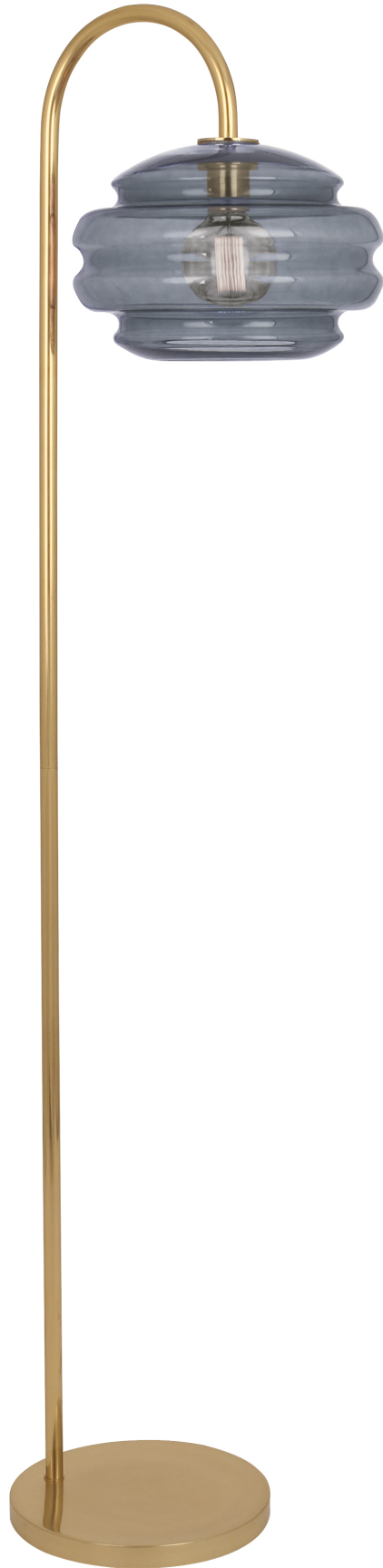

# Horizon

---

[Click photo above to watch Horizon Task Floor Lamp Video](#)

A modern spin on classic beehive glass, the Horizon collection features charming contours that have sculptural appeal while remaining airy and light. Available in both clear and smoke gray glass, Horizon is an ideal choice for making a beautiful statement in your home.

---

# | Horizon





# Horizon

---

[Click photo above to watch Horizon Accent Lamp Video](#)

A modern spin on classic beehive glass, the Horizon collection features charming contours that have sculptural appeal while remaining airy and light. Available in both clear and smoke gray glass, Horizon is an ideal choice for making a beautiful statement in your home.

---

# | Horizon

---



# Horizon

---

[Click photo above to watch Horizon Task Table Lamp Video](#)

A modern spin on classic beehive glass, the Horizon collection features charming contours that have sculptural appeal while remaining airy and light. Available in both clear and smoke gray glass, Horizon is an ideal choice for making a beautiful statement in your home.

---



CL62



CL60



GY61



GY63

# Horizon

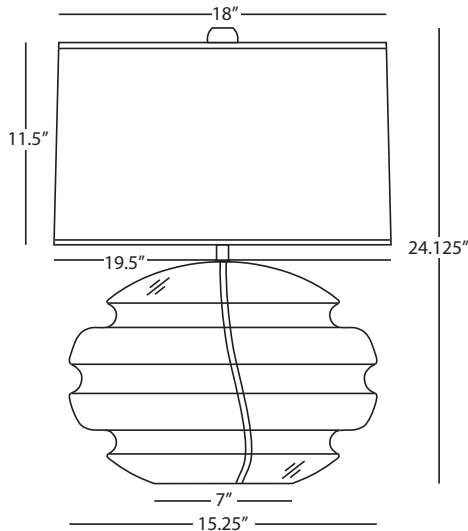

HORIZON

## CL60

### Table Lamp

1 - 150W Max.  
 Bulb Type: A  
 Switch: Full Range Dimmer  
 Clear Glass Body w/  
 Modern Brass Accents  
 Oyster Linen Shade w/  
 Self Fabric Top Diffuser  
 Black Fabric Wrapped Cord

FINISH OPTION:  
**GY60** Smoke Gray Glass

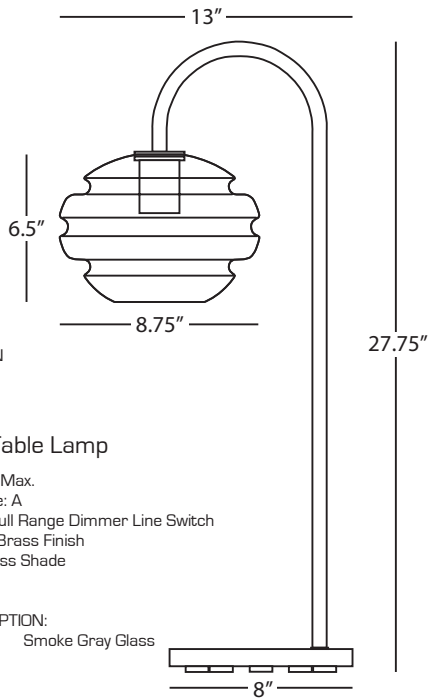

HORIZON

## CL62

### Task Table Lamp

1 - 60W Max.  
 Bulb Type: A  
 Switch: Full Range Dimmer Line Switch  
 Modern Brass Finish  
 Clear Glass Shade

FINISH OPTION:  
**GY62** Smoke Gray Glass

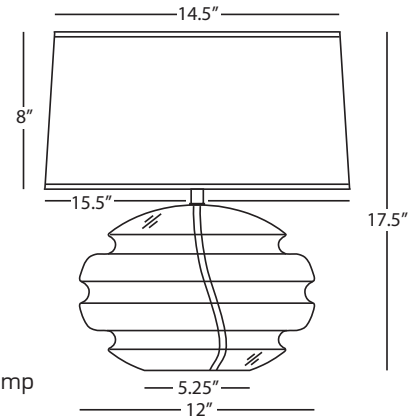

HORIZON

## GY61

### Accent Lamp

1 - 60W Max.  
 Bulb Type: A  
 Switch: Full Range Dimmer  
 Smoke Grey Glass Body w/  
 Modern Brass Accents  
 Oyster Linen Shade w/  
 Self Fabric Top Diffuser  
 Black Fabric Wrapped Cord

FINISH OPTION:  
**CL61** Clear Glass

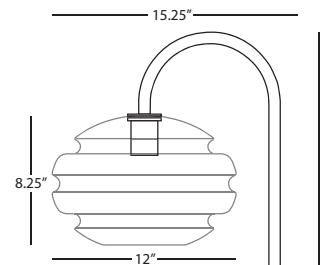

HORIZON

## GY63

### Task Floor Lamp

1 - 100W Max.  
 Bulb Type: G, Medium Base  
 Switch: Full Range Dimmer Line Switch  
 Modern Brass Finish  
 Smoke Gray Glass Shade

FINISH OPTION:  
**CL63** Clear Glass

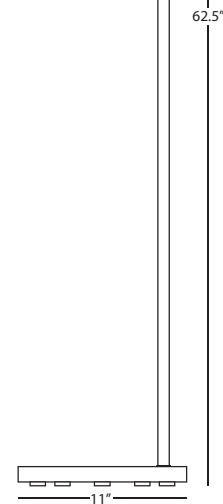

# Horizon



# Horizon

---

[Click photo above to watch Horizon Flush Mount Video](#)

A modern spin on classic beehive glass, the Horizon collection features charming contours that have sculptural appeal while remaining airy and light. Available in both clear and smoke gray glass, Horizon is an ideal choice for making a beautiful statement in your home.

---

# Horizon

---





# Horizon

---

[Click photo above to watch Horizon Pendant Video](#)

A modern spin on classic beehive glass, the Horizon collection features charming contours that have sculptural appeal while remaining airy and light. Available in both clear and smoke gray glass, Horizon is an ideal choice for making a beautiful statement in your home.

---



GY65



CL64



GY64



CL65

# Horizon

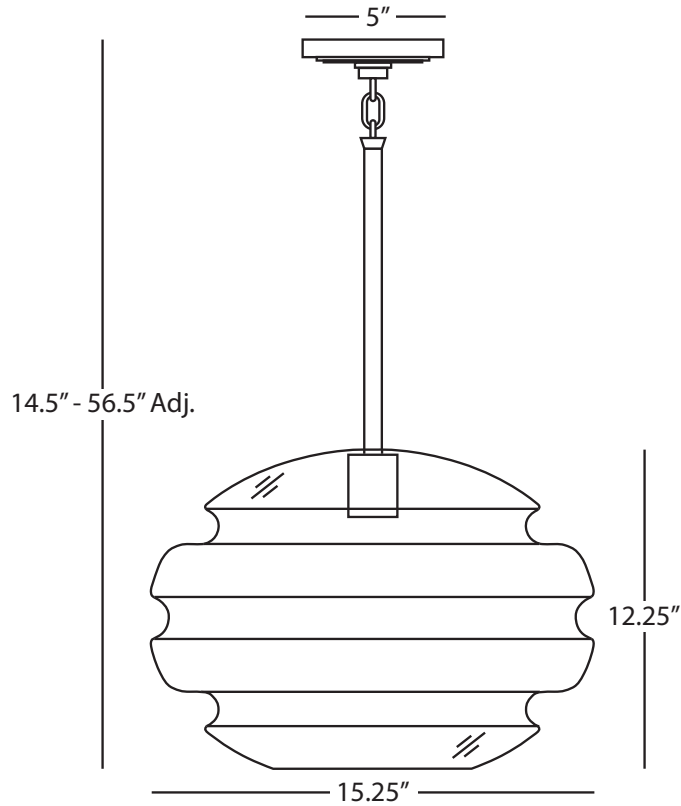

HORIZON

## CL65

Pendant

1 - 150W Max.

Bulb Type: G, Medium Base

Direct Wire

Clear Glass Shade w/

Modern Brass Accents

Susp. Hardware: 3 pcs. 5/8" x 12" &

1 pc. 5/8" x 6" Extensions

FINISH OPTION:

**GY65** Smoke Gray Glass

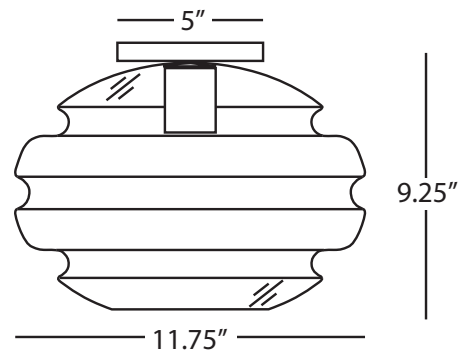
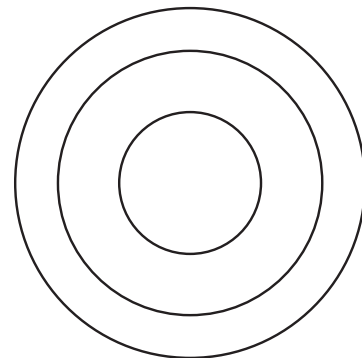

HORIZON

## CL64

Flush Mount

1 - 100W Max.

Bulb Type: G, Medium Base

Direct Wire

Clear Glass Shade w/

Modern Brass Accents

FINISH OPTION:

**GY64** Smoke Gray Glass



216



S215



Z215

# Hudson

HUDSON

## S215 Table Lamp

2 - 150W Max.  
Bulb Type: A  
Switch: Hi-Lo Pull Chains  
Polished Nickel Finish w/  
White Marble Accents  
Oyster Linen Shade

FINISH OPTIONS:

**215** Modern Brass  
**Z215** Deep Patina Bronze

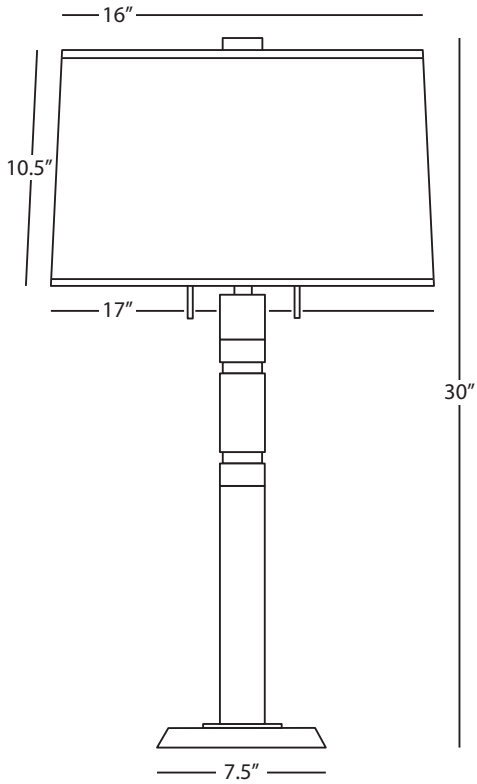

HUDSON

## 216 Floor Lamp

2 - 150W Max.  
Bulb Type: A  
Switch: Hi-Lo Pull Chains  
Modern Brass Finish w/  
White Marble Accents  
Oyster Linen Shade

FINISH OPTIONS:

**S216** Polished Nickel  
**Z216** Deep Patina Bronze

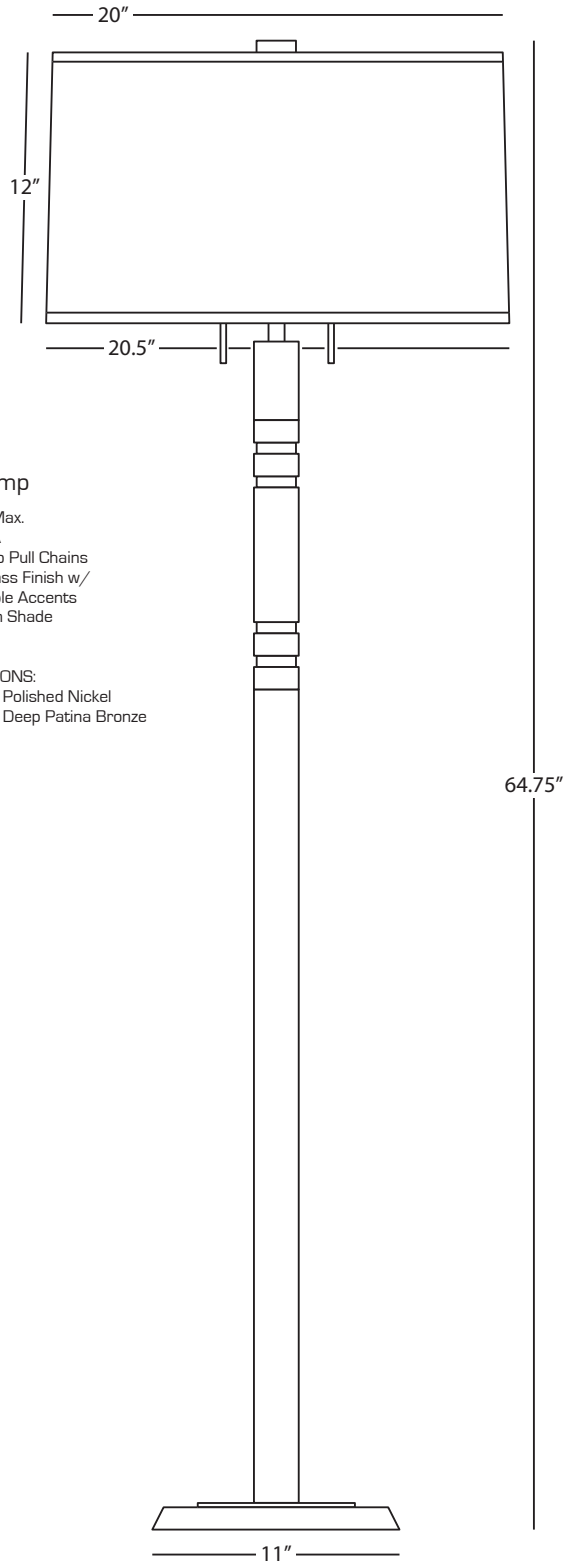



2815



2815X

# Hugo

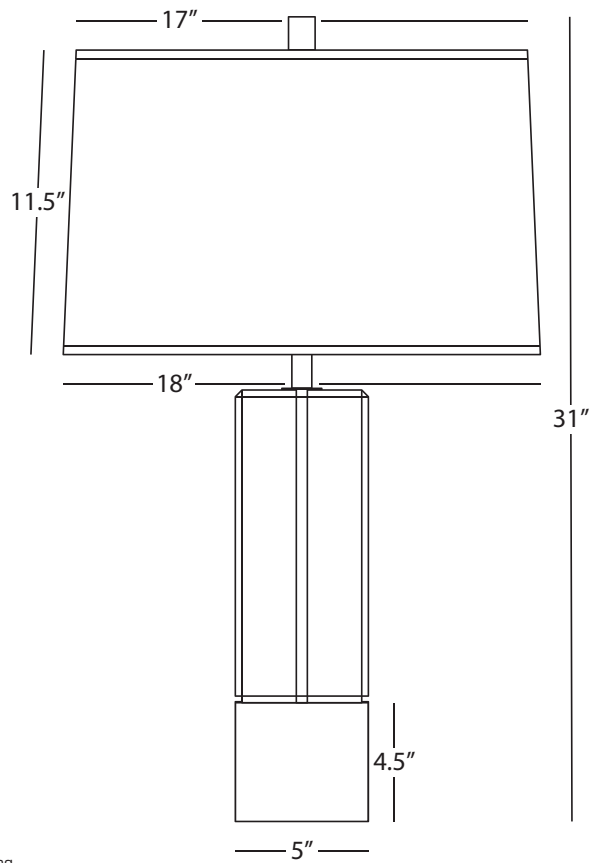
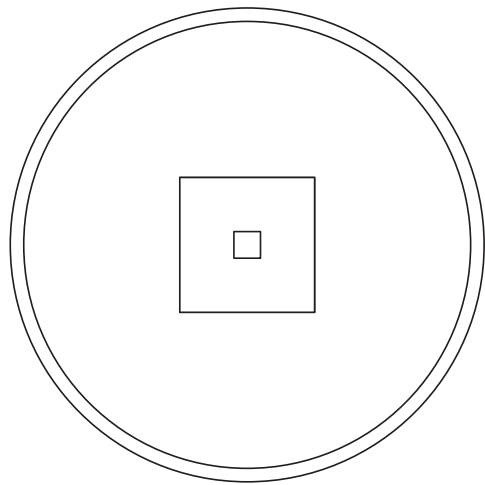

HUGO

## 2815

### Table Lamp

1 - 150W Max.  
Bulb Type: A  
Switch: Hi-Lo Dimming  
Clear Crystal Column  
Carrara Marble Base  
Polished Nickel Accents  
Pearl Gray Fabric Shade

SHADE OPTION:

**2815X** Smoke Gray



S529



529



# Jace

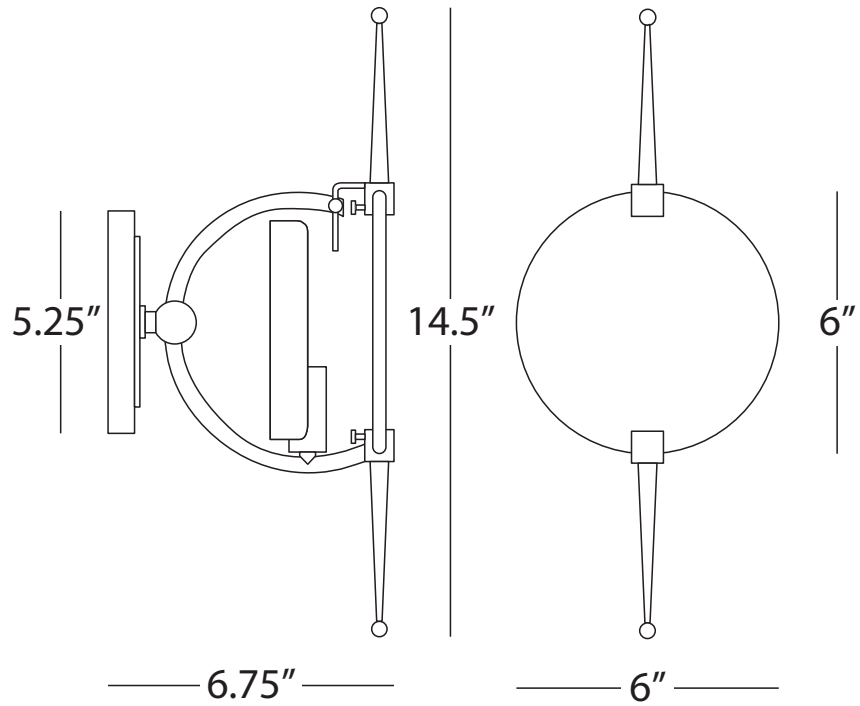

JACE

**529**

Wall Sconce

1 - 60W Max.  
Bulb Type: B, Candelabra  
Switch: On-Off Line Switch  
24" Cord Cover/Direct Wire  
Modern Brass Finish  
Polished, Faux Alabaster Disc  
Perforated Metal Diffuser

FINISH OPTION:

**S529** Polished Nickel



MR210



EG210



AP210



AM210



EB210

# Jasmine

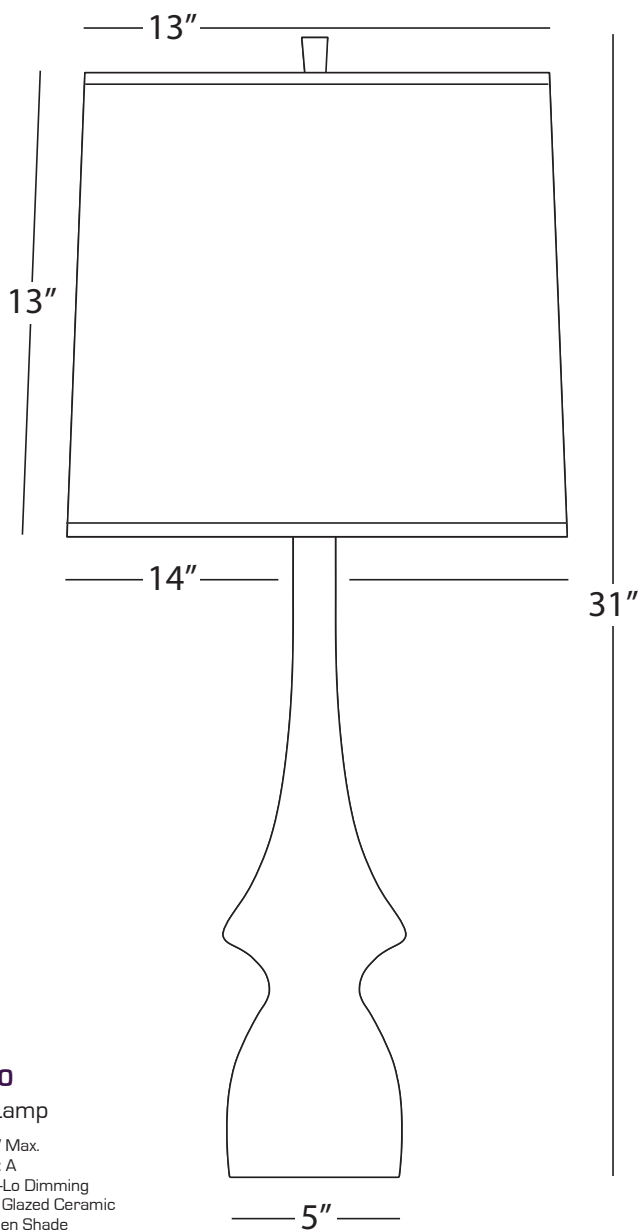

JASMINE

## AM210

Table Lamp

1 - 150W Max.  
Bulb Type: A  
Switch: Hi-Lo Dimming  
Amethyst Glazed Ceramic  
Oyster Linen Shade

See Page 231 for Color Options



209B



S209

# Jeannie

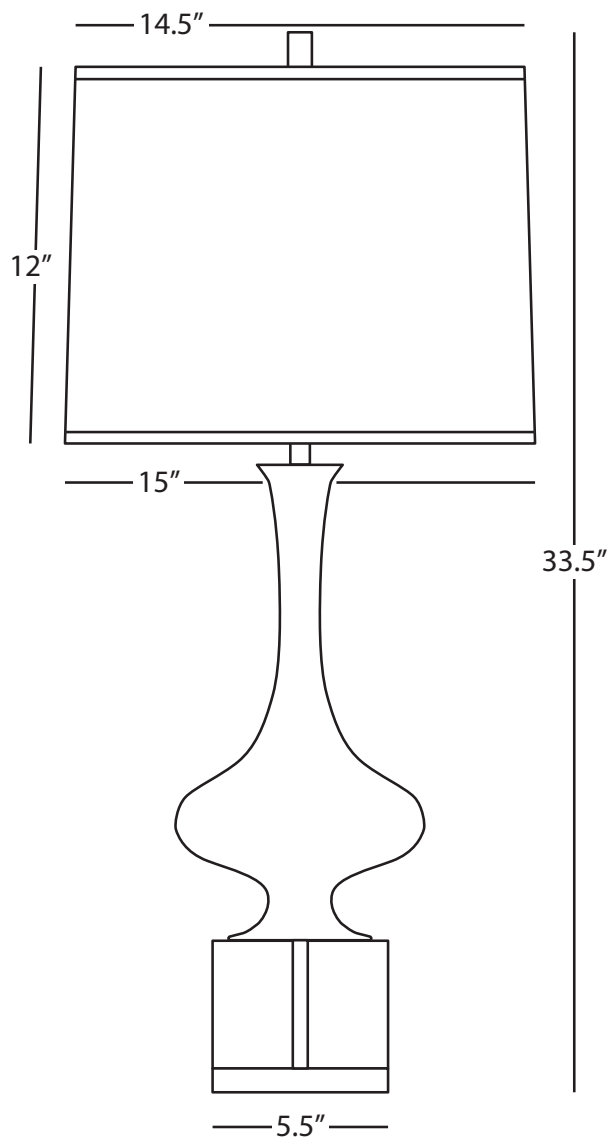

JEANNIE

**209B**

Table Lamp

1 - 150W Max.  
Bulb Type: A  
Switch: Full Range Dimmer  
Modern Brass Finish  
Clear Crystal Base  
Black Opaque Parchment Shade w/ Gold Lining

FINISH/ SHADE OPTIONS:

**209** Modern Brass/ Fondine Shade  
**S209** Polished Nickel/ Fondine Shade  
**S209B** Polished Nickel/ Black Parchment w/ Silver Lining



CL993



BT93



BB91



ST991

JUNE

## BB91

### Accent Lamp

1 - 150W Max.  
Bulb Type: A  
Switch: Full Range Dimmer Line Switch  
Baby Blue Glazed Ceramic  
Buff Linen Shade

See Page 233 for Color/Shade Options

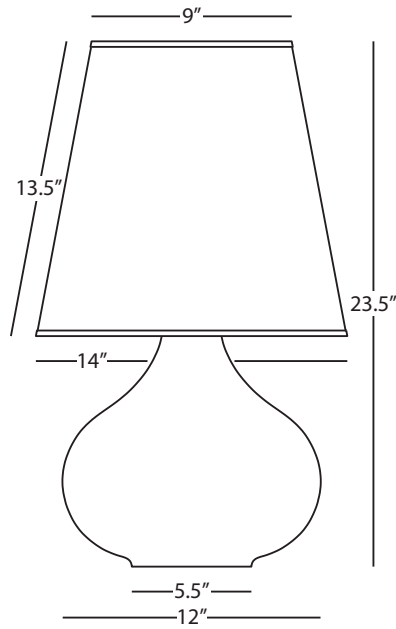

JUNE

## CL993

### Table Lamp

1 - 150W Max.  
Bulb Type: A  
Switch: Hi-Lo Dimming  
Celadon Glazed Ceramic  
Oyster Linen Shade

See Page 233 for Color/Shade Options

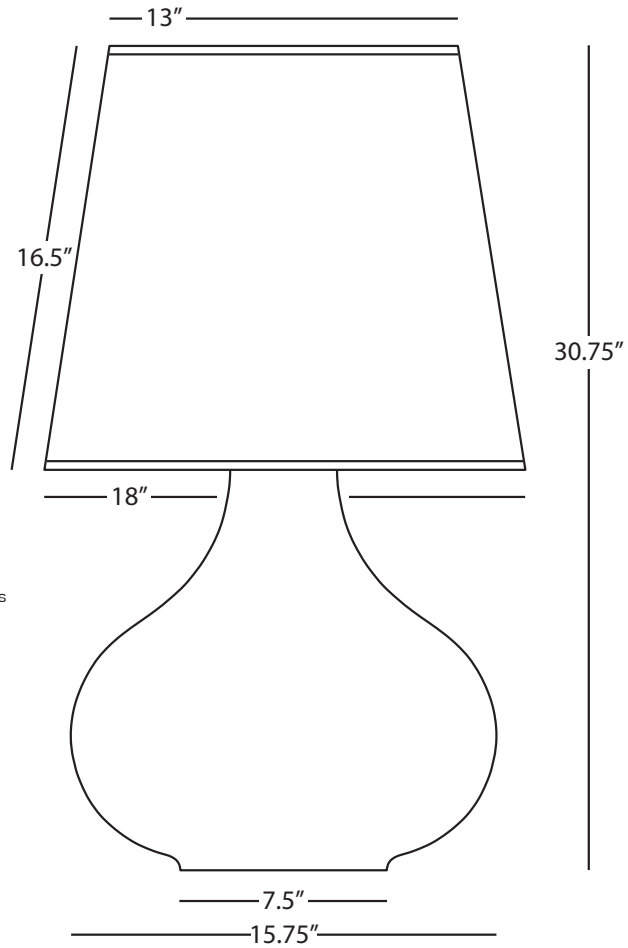



458B



459W



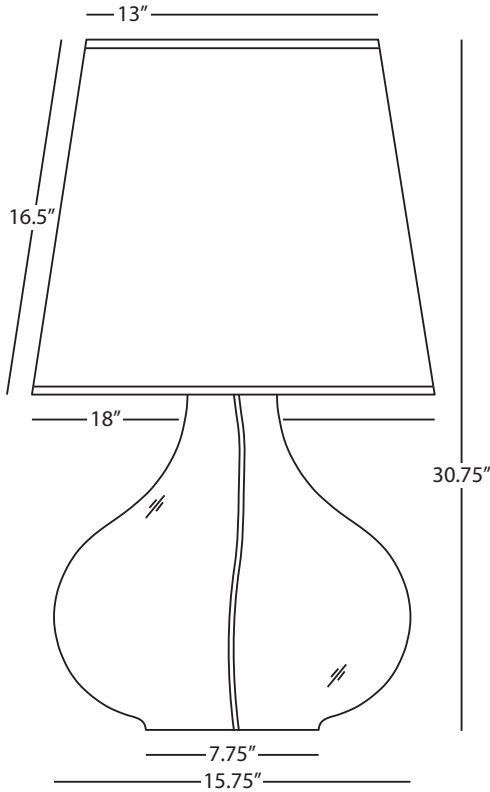

JUNE

**459W**

**Glass Table Lamp**

- 1 - 150W Max.
- Bulb Type: A
- Switch: Full Range Dimmer Line Switch
- Clear Glass Body
- Black Fabric Wrapped Cord
- White Organza Fabric Shade

SHADE OPTION:

**459B** Black Organza

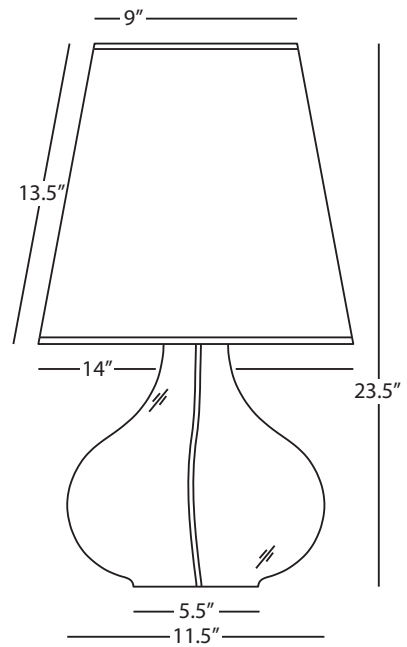

JUNE

**458B**

**Glass Accent Lamp**

- 1 - 150W Max.
- Bulb Type: A
- Switch: Full Range Dimmer Line Switch
- Clear Glass Body
- Black Fabric Wrapped Cord
- Black Organza Fabric Shade

SHADE OPTION:

**458W** White Organza



207



S207B

# Juno

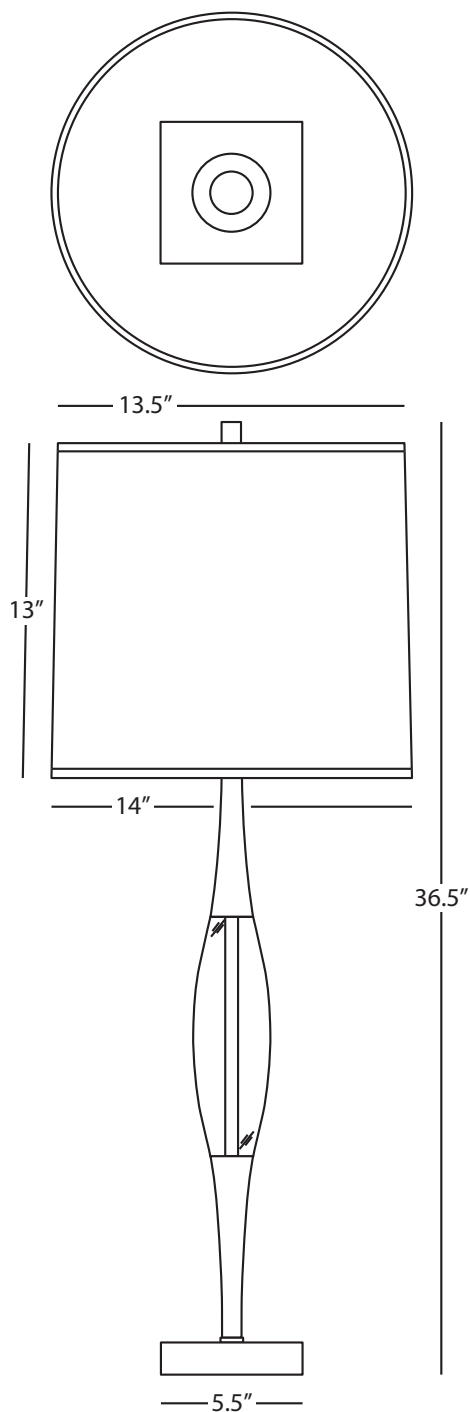

JUNO

## 207 Table Lamp

1 - 150W Max.  
Bulb Type: A  
Switch: Full Range Dimmer  
Modern Brass Finish w/  
Clear Crystal Accent  
Pearl Dupioni Fabric Shade  
USB Port on Base

### FINISH/SHADE OPTIONS:

- 207B** Modern Brass/Black Parchment  
w/ Matte Gold Lining
- S207** Polished Nickel/Pearl Dupioni
- S207B** Polished Nickel/Black Parchment  
w/ Matte Silver Lining



PG203



VW203



AW202



SG202

# Kate

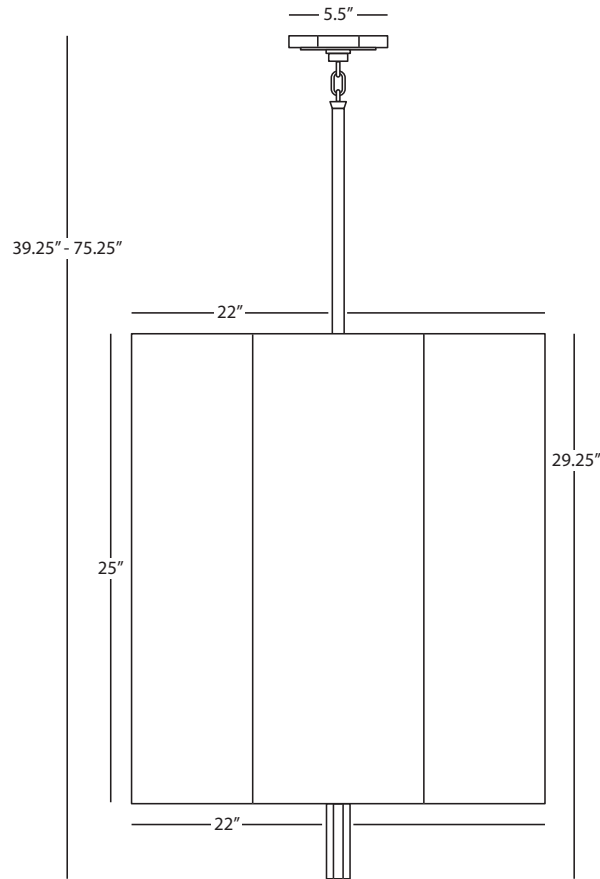
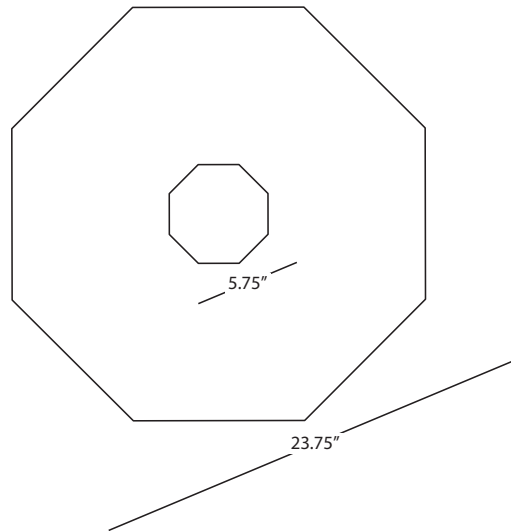

KATE

## AW202

### Pendant

6 - 100W Max.

Bulb Type: A

Direct Wire

Modern Brass Finish w/

Clear Crystal Finial

Octagonal Ascot White Fabric Shade

Susp. Hardware: 1 pc. 5/8" x 6" & 3 pcs. 5/8" x 12" Extensions

#### FINISH/SHADE OPTIONS:

- PG202** Modern Brass/Pearl Gray
- SG202** Modern Brass/Smoke Gray
- VW202** Modern Brass/Vintage Wine
- AW203** Polished Nickel/Ascot White
- PG203** Polished Nickel/Pearl Gray
- SG203** Polished Nickel/Smoke Gray
- VW203** Polished Nickel/Vintage Wine

Kate



# Kate

[Click photo above to watch Kate Table Lamp Video](#)

Make a bold statement in your space with the Kate collection from Robert Abbey! Featuring an oversized, octagonal shade and a dazzling crystal accent, Kate is certainly impressive. Kate is a fresh take on classic design.

| Kate





# Kate

---

[Click photo above to watch Kate Floor Lamp Video](#)

Make a bold statement in your space with the Kate collection from Robert Abbey! Featuring an oversized, octagonal shade and a dazzling crystal accent, Kate is certainly impressive. Kate is a fresh take on classic design.

---



SG07



PG04



AW07



VW04

# Kate

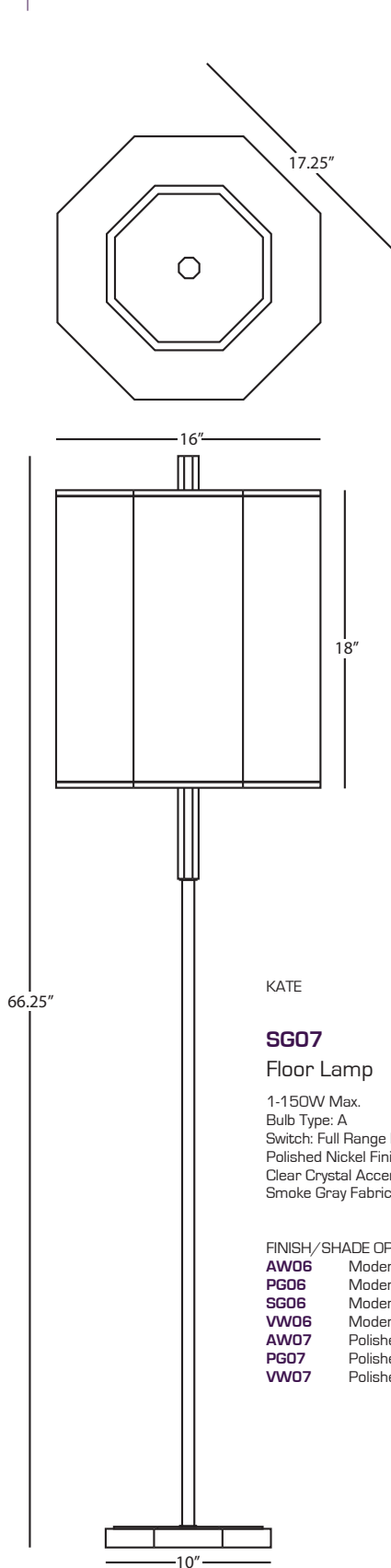

KATE

## SG07

### Floor Lamp

1-150W Max.  
 Bulb Type: A  
 Switch: Full Range Dimmer  
 Polished Nickel Finish w/  
 Clear Crystal Accents  
 Smoke Gray Fabric Shade

#### FINISH/SHADE OPTIONS:

**AW06** Modern Brass/Ascot White  
**PG06** Modern Brass/Pearl Gray  
**SG06** Modern Brass/Smoke Gray  
**VW06** Modern Brass/Vintage Wine  
**AW07** Polished Nickel/Ascot White  
**PG07** Polished Nickel/Pearl Gray  
**VW07** Polished Nickel/Vintage Wine

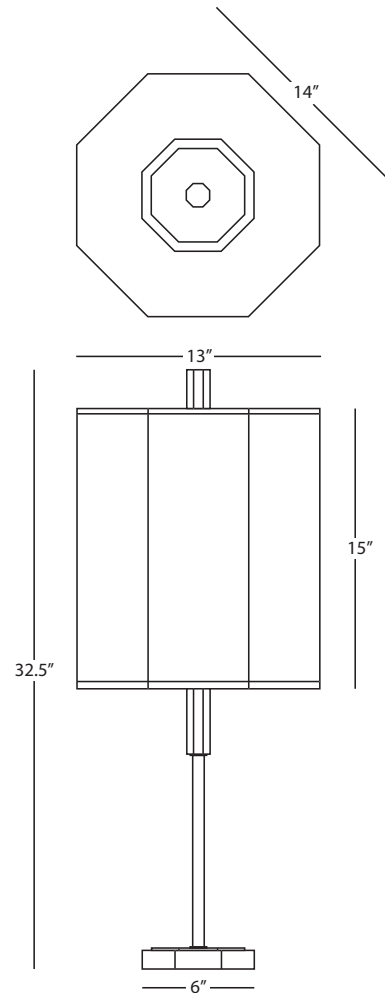

KATE

## VW04

### Table Lamp

1-150W Max.  
 Bulb Type: A  
 Switch: Full Range Dimmer  
 Modern Brass Finish w/  
 Clear Crystal Accents  
 Vintage Wine Fabric Shade

#### FINISH/SHADE OPTIONS:

**AW04** Modern Brass/Ascot White  
**PG04** Modern Brass/Pearl Gray  
**SG04** Modern Brass/Smoke Gray  
**AW05** Polished Nickel/Ascot White  
**PG05** Polished Nickel/Pearl Gray  
**SG05** Polished Nickel/Smoke Gray  
**VW05** Polished Nickel/Vintage Wine



1505



Z1504DBZ



B1504BRC



Z1504ALT



1500

# Kinetic

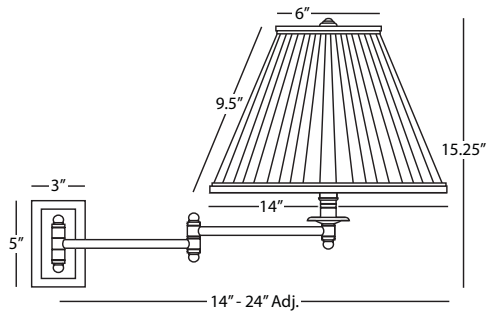

KINETIC

## **B1504BRC** Swing Arm Sconce

1 - 150W Max.  
Bulb Type: A  
Switch: 3-Way  
24" Cord Cover/Direct Wire  
Brushed Chrome Finish  
Pearl White Side Pleat Fabric Shade

### FINISH/SHADE OPTIONS:

<b>1504</b>	Antique Brass Natural Side Pleat Fabric
<b>1504ALT</b>	Antique Brass Oyster Linen
<b>1504X</b>	Antique Brass Ascot Bone Fabric
<b>B1504ALT</b>	Brushed Chrome Oyster Linen
<b>B1504XXX</b>	Brushed Chrome Ascot White Fabric
<b>Z1504ALT</b>	Deep Patina Bronze Oyster Linen
<b>Z1504DBZ</b>	Deep Patina Bronze Natural Side Pleat Fabric
<b>Z1504XXX</b>	Deep Patina Bronze Translucent Flax Parchment

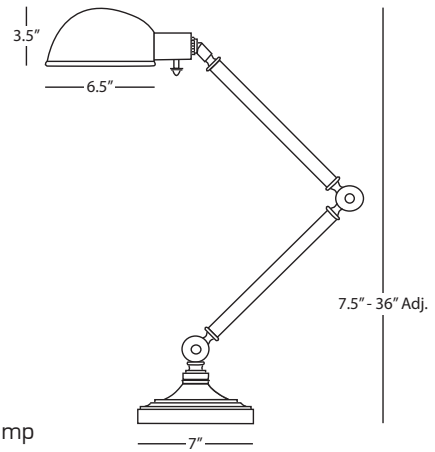

KINETIC

## **1500** Adjustable Task Table Lamp

1 - 60W Max.  
Bulb Type: A  
Switch: Hi-Lo Dimming  
Antique Brass Finish  
Metal Shade

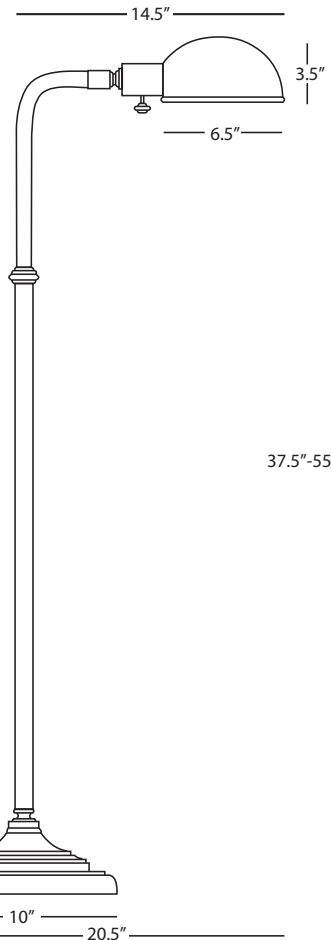

KINETIC

## **1505** Adjustable Task Floor Lamp

1 - 60W Max.  
Bulb Type: A  
Switch: Hi-Lo Dimming  
Antique Brass Finish  
Metal Shade

### FINISH OPTION:

**Z1505DBZ** Deep Patina Bronze



# Koleman

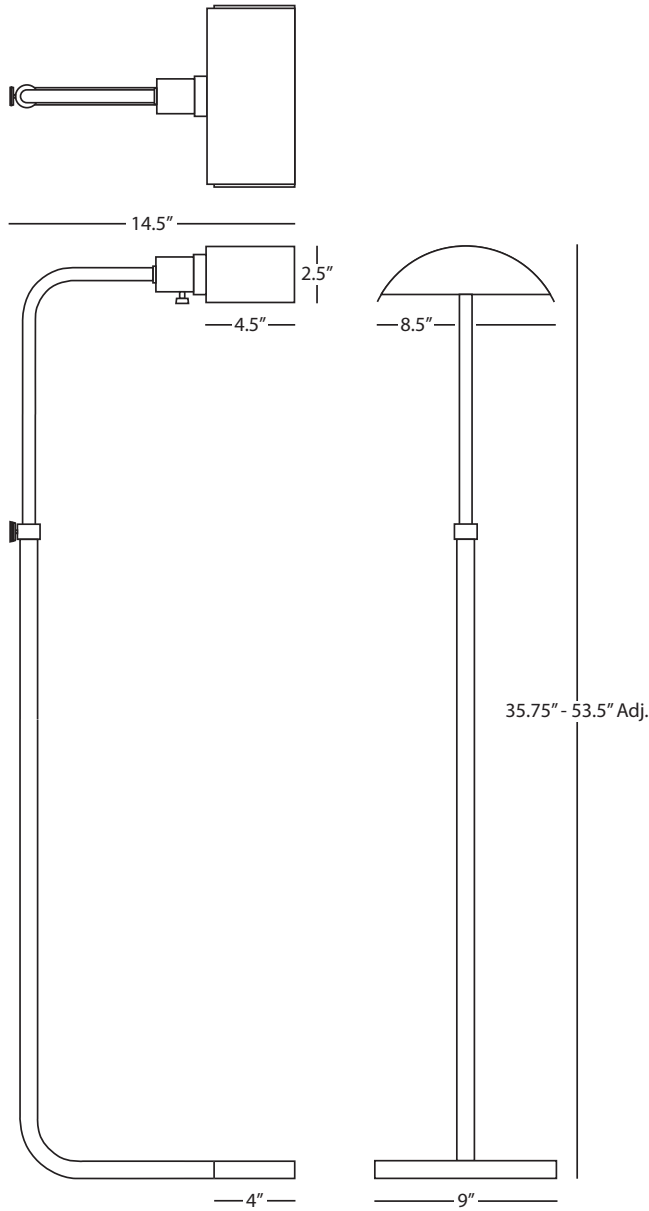

KOLEMAN

## S461

### Adjustable Task Floor Lamp

1 - 60W Max.  
 Bulb Type: B11, Torpedo  
 Switch: Hi-Lo Dimming  
 Polished Nickel Finish  
 Metal Shade

FINISH OPTIONS:

**461** Aged Brass  
**Z461** Deep Patina Bronze

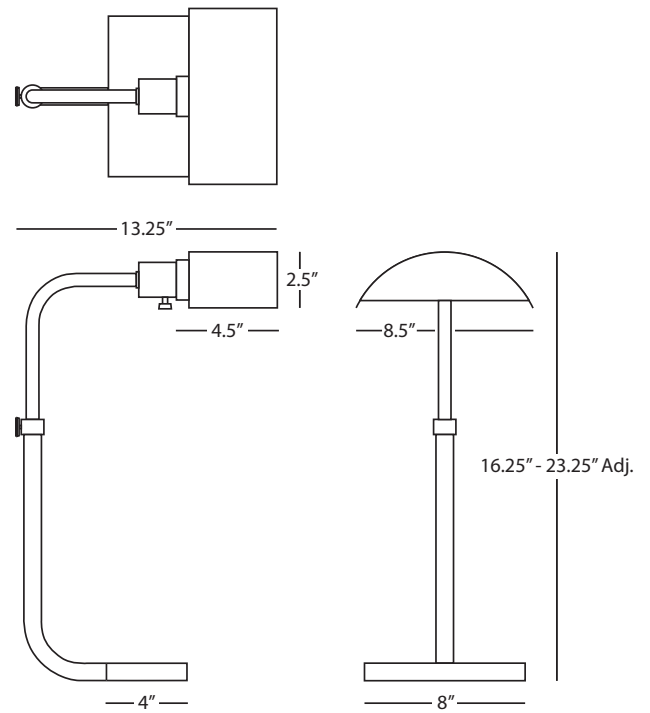

KOLEMAN

## Z460

### Adjustable Task Table Lamp

1 - 60W Max.  
 Bulb Type: B11, Torpedo  
 Switch: Hi-Lo Dimming  
 Deep Patina Bronze Finish  
 Metal Shade

FINISH OPTIONS:

**460** Aged Brass  
**S460** Polished Nickel



463



S464



Z462



# Koleman

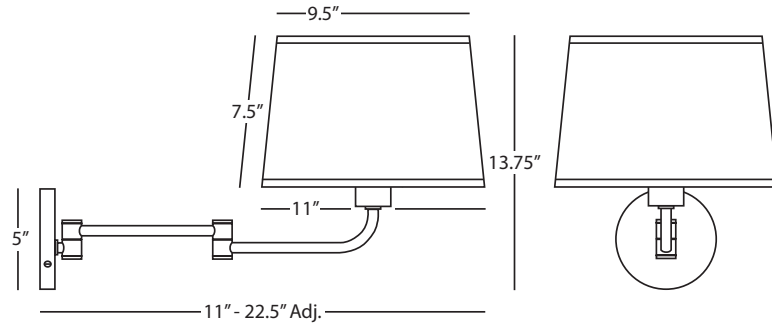

KOLEMAN

## S464 Swing Arm Sconce

1 - 100W Max.  
Bulb Type: A  
Switch: Hi-Lo Dimming  
24" Cord Cover/Direct Wire  
Polished Nickel Finish  
Oyster Linen Shade

FINISH OPTIONS:  
**464** Aged Brass  
**Z464** Deep Patina Bronze

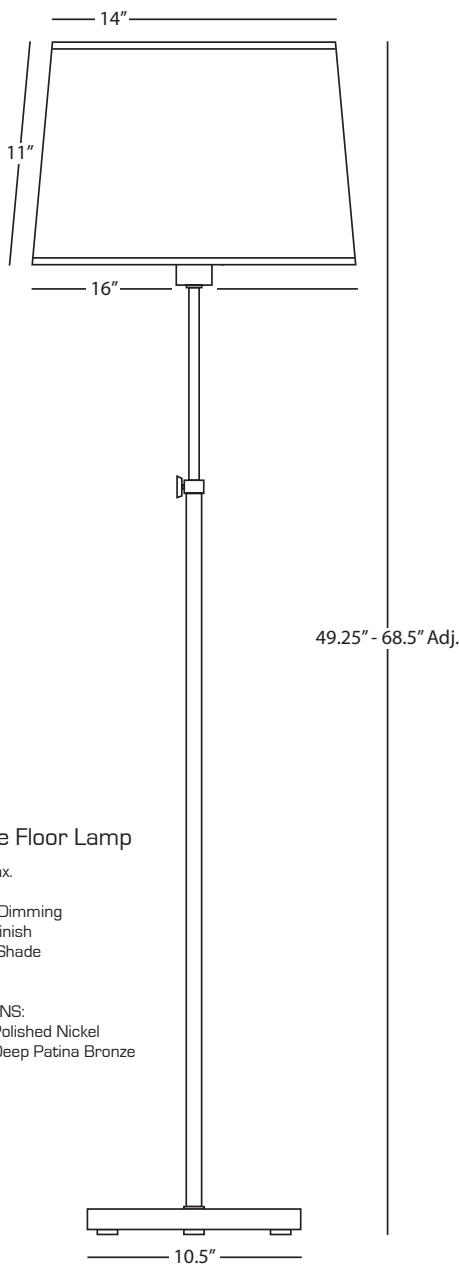

KOLEMAN

## 463 Adjustable Floor Lamp

1 - 100W Max.  
Bulb Type: A  
Switch: Hi-Lo Dimming  
Aged Brass Finish  
Oyster Linen Shade

FINISH OPTIONS:  
**S463** Polished Nickel  
**Z463** Deep Patina Bronze

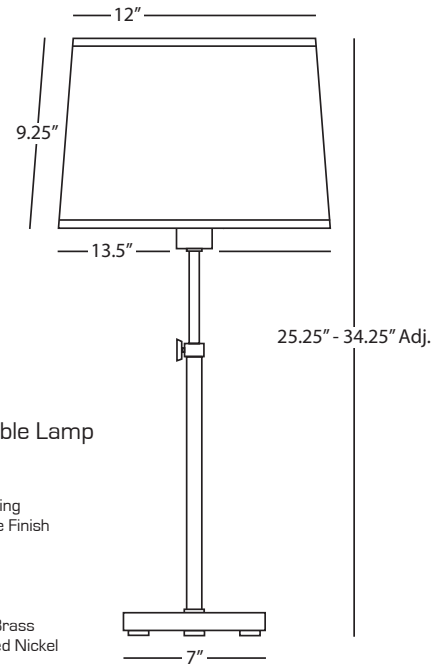

KOLEMAN

## Z462 Adjustable Table Lamp

1 - 100W Max.  
Bulb Type: A  
Switch: Hi-Lo Dimming  
Deep Patina Bronze Finish  
Oyster Linen Shade

FINISH OPTIONS:  
**462** Aged Brass  
**S462** Polished Nickel



3376



3373



3374

# Latitude

LATITUDE

## 3374

### Wall Sconce

1 - 60W Max.  
 Bulb Type: B10 Candelabra  
 Switch: Hi-Lo Line Switch  
 24" Cord Cover/ Direct Wire  
 Aged Brass Finish w/ Clear Glass Accents  
 Oyster Grey Silk Shade w/ Gold Foil Lining

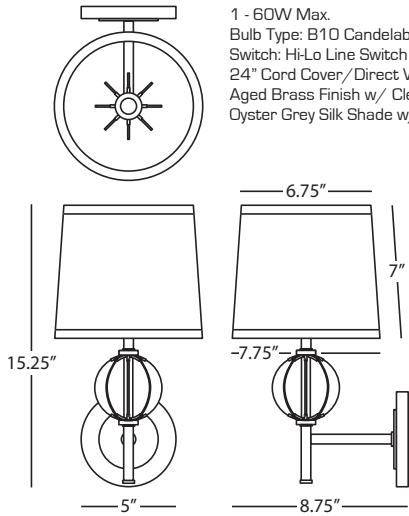

LATITUDE

## 3373

### Pendant

1 - 100W Max.  
 Bulb Type: A  
 Direct Wire  
 Aged Brass Finish w/ Clear Glass Accents  
 Susp. Hardware: 1 pc. 5/8" x 6" & 3 pcs. 5/8" x 12" Extensions

Ships w/ 1 - 30W Filament Bulb

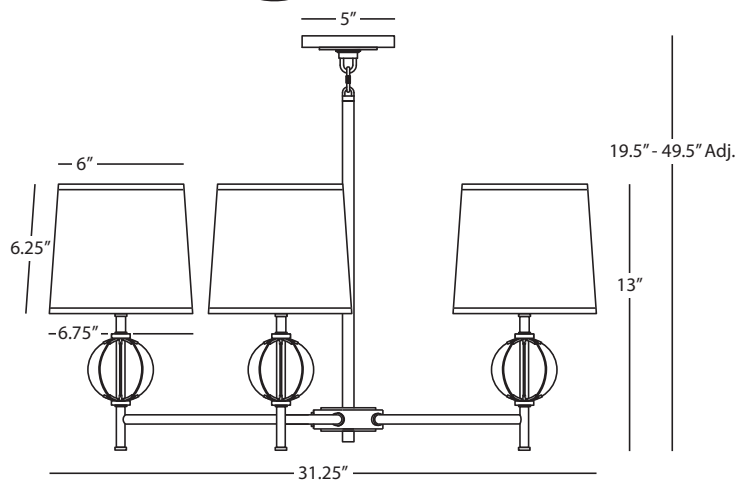
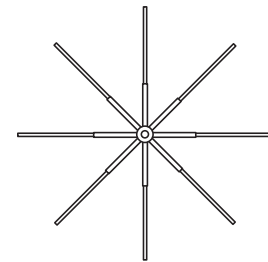
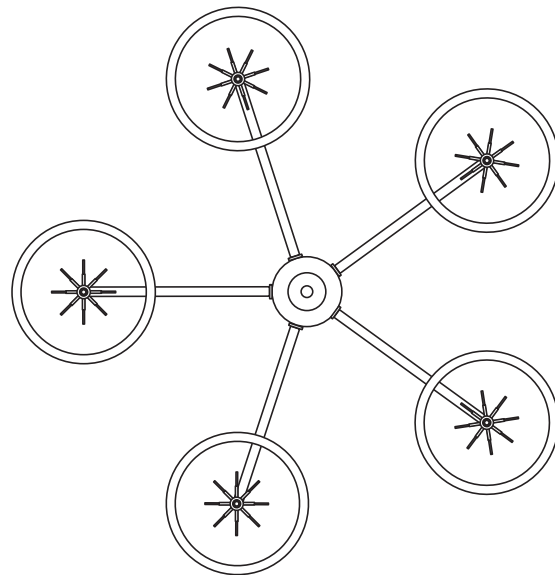
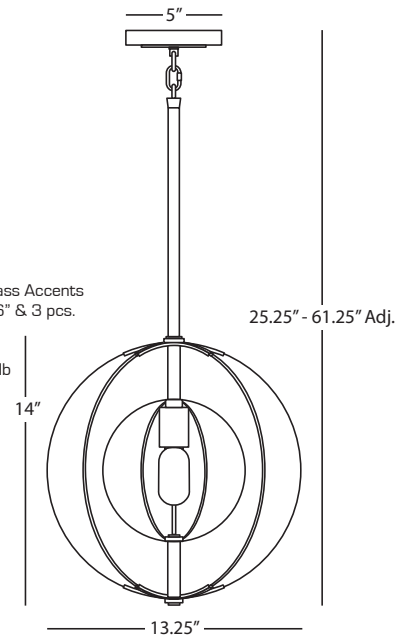

LATITUDE

## 3376

### Chandelier

5 - 60W Max.  
 Bulb Type: B, Candelabra  
 Direct Wire  
 Aged Brass Finish w/ Clear Glass Accents  
 Oyster Grey Silk Shades w/ Gold Foil Lining  
 Susp. Hardware: 1 pc. 5/8" x 6" & 3 pcs. 5/8" x 12" Extensions



1341



S1340

# Ledger

LEDGER

## S1340

### Table Lamp

1 - 60W Max.  
 Bulb Type: B, Candelabra  
 Switch: 4-Way Touch Switch  
 Polished Nickel Finish w/  
 Dark Walnut Accents  
 Metal Shade  
 USB Port on Base

FINISH OPTION:

**1340** Warm Brass

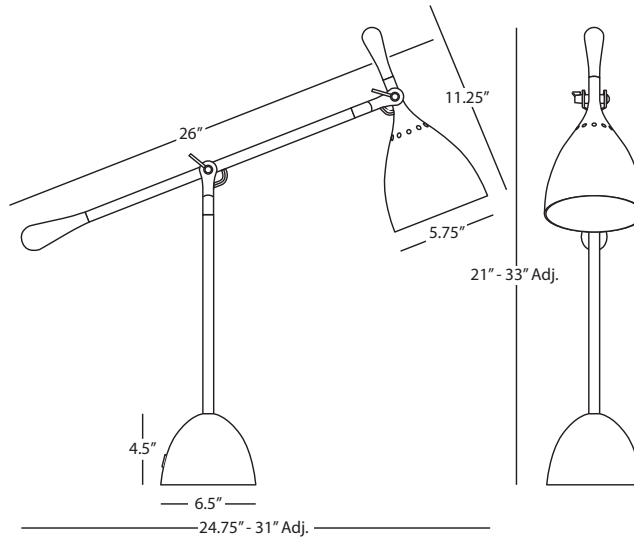

LEDGER

## 1341

### Floor Lamp

1 - 60W Max.  
 Bulb Type: A  
 Switch: Full Range Dimmer Line Switch  
 Warm Brass Finish w/  
 Dark Walnut Accents  
 Metal Shade

FINISH OPTION:

**S1341** Polished Nickel

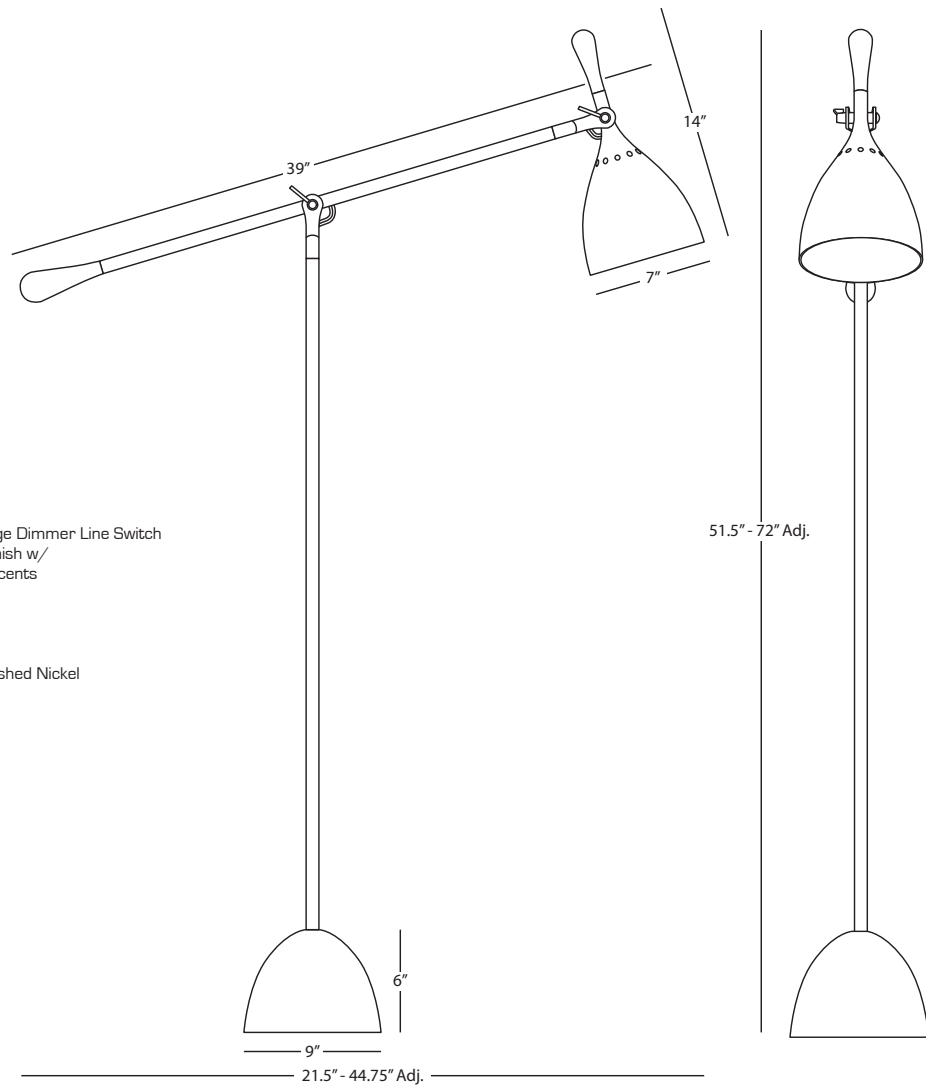

# Lincoln



# Lincoln

[Click photo above to watch Lincoln Table Lamp video](#)

Clear crystal and sturdy modern brass accents give the Lincoln collection a handsome yet ethereal presence. Lincoln is perfect for creating a sense of balance and harmony in contemporary spaces.



1011



1011B



1012B



1012



# Lincoln

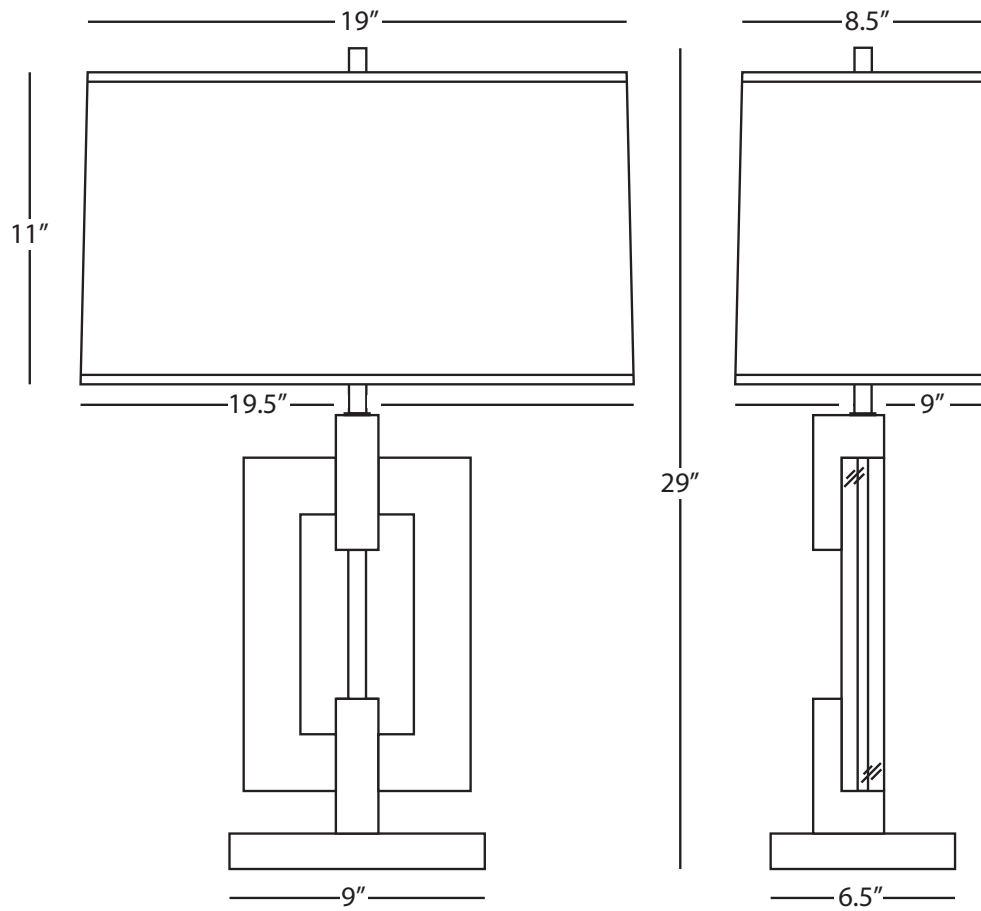

LINCOLN

## 1011

### Table Lamp

1 - 150W Max.

Bulb Type: A

Switch: Full Range Dimmer

Clear Crystal w/ Modern Brass Accents

Pearl Dupioni Silk Shade

#### FINISH/SHADE OPTIONS:

**1011B** Modern Brass/Black Parchment w/  
Matte Gold Lining

**1012** Polished Nickel/Pearl Dupioni Silk

**1012B** Polished Nickel/Black Parchment w/  
Matte Silver Lining



2792



2295B

# Logan

LOGAN

## 2295B

### Table Lamp

1 - 150W Max.  
 Bulb Type: A  
 Switch: Hi-Lo Dimming  
 Aged Brass Finish  
 Travertine Stone Base  
 Oval Black Painted Opaque Parchment  
 Shade w/ Copper Foil Lining

FINISH/SHADE OPTIONS:

- 2295** Aged Brass/ Travertine Stone  
Oval Fondine Fabric Shade
- 2791** Polished Nickel/ Carrara Marble  
Ascot White Fabric
- 2791B** Polished Nickel/ Carrara Marble  
Black Painted Opaque Parchment  
w/ Silver Foil Lining

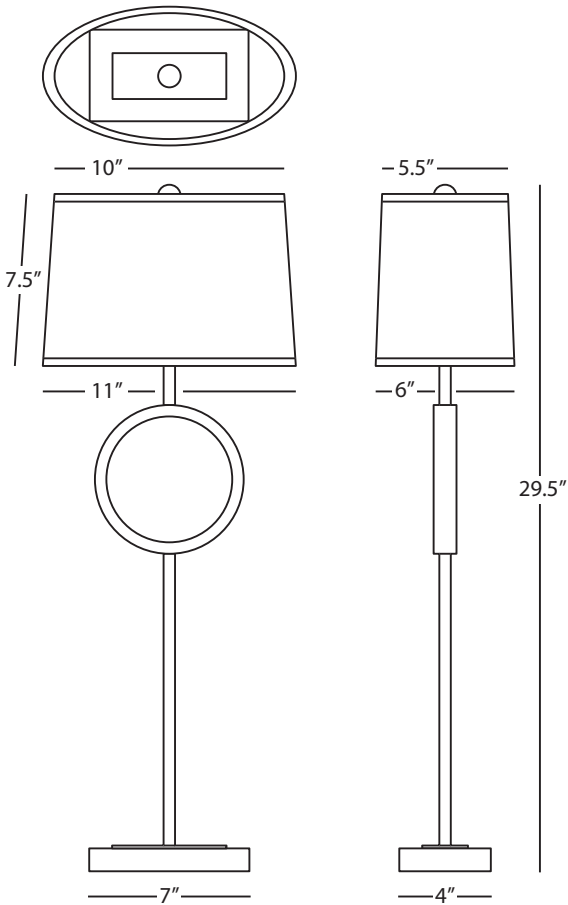
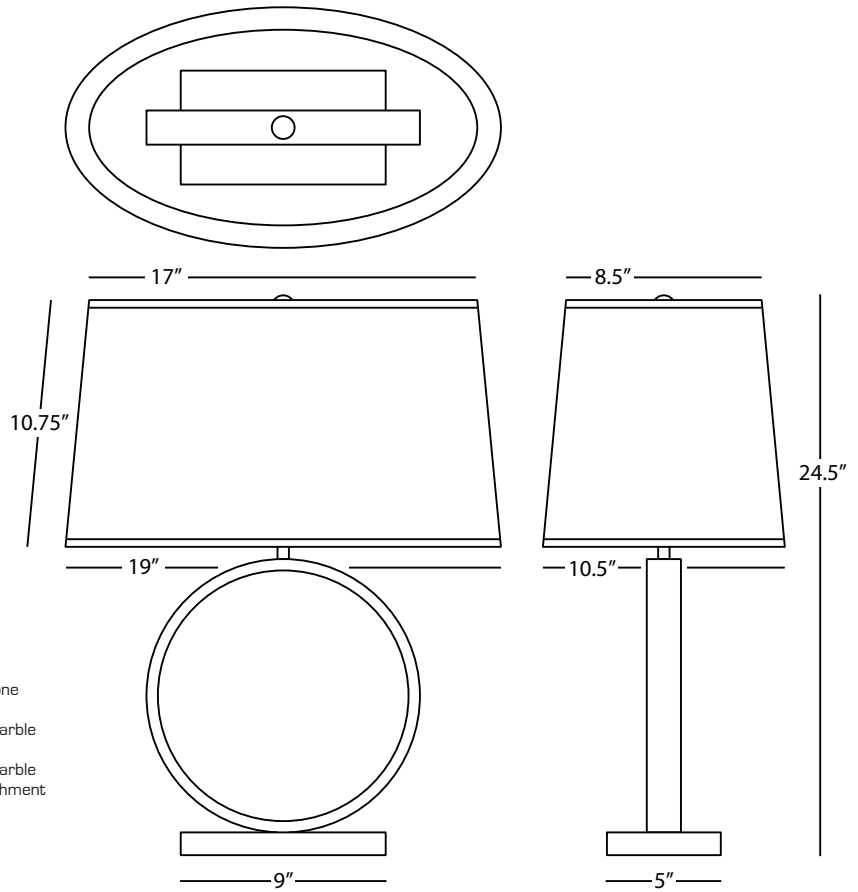

LOGAN

## 2792

### Buffet Table Lamp

1 - 60W Max.  
 Bulb Type: B, Candelabra  
 Switch: Hi-Lo Line Switch  
 Polished Nickel Finish  
 Carrara Marble Base  
 Oval Ascot White Fabric Shade

FINISH/SHADE OPTIONS:

- 2792B** Polished Nickel/ Carrara Marble  
Black Painted Opaque Parchment  
w/ Silver Foil Lining
- 2257** Aged Brass/ Travertine Stone  
Fondine Fabric
- 2257B** Aged Brass/ Travertine Stone  
Black Painted Opaque Parchment  
w/ Copper Foil Lining



W201



200

# Marcel

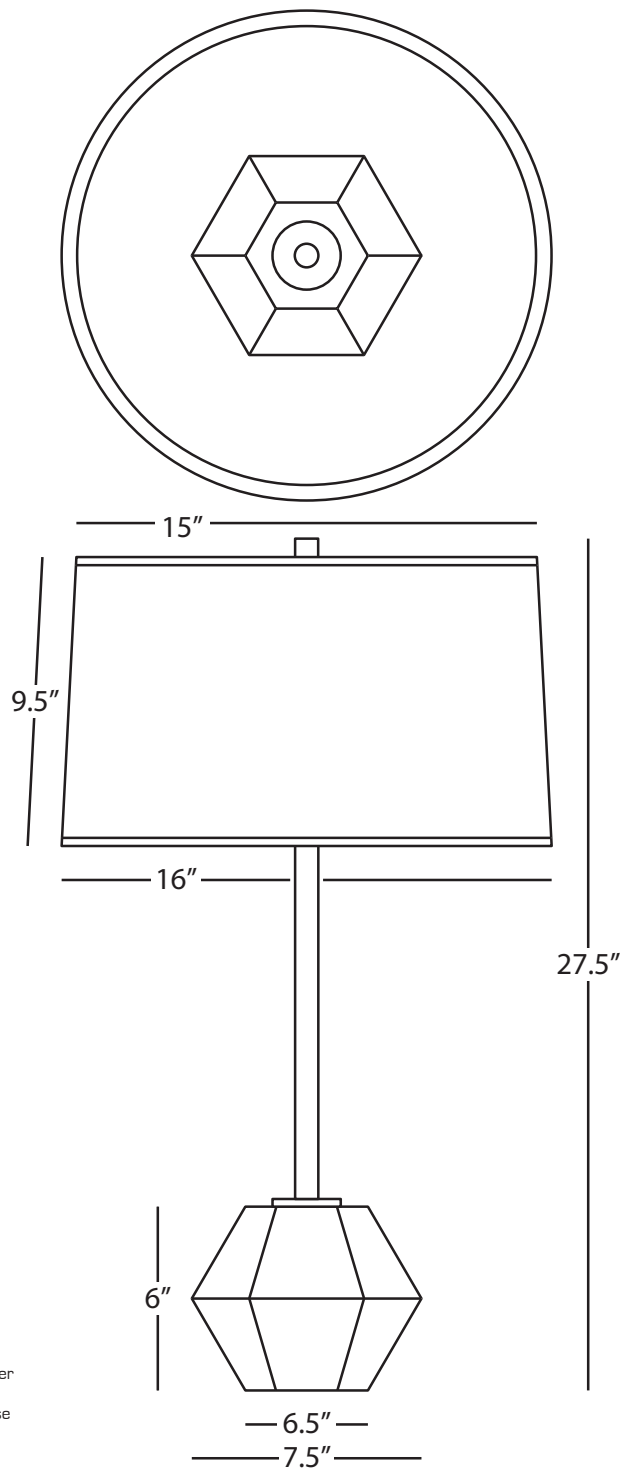

MARCEL

**200**

Table Lamp

1 - 150W Max.

Bulb Type: A

Switch: Full Range Dimmer

Modern Brass Finish

Matte Black Faceted Base

Oyster Linen Shade

FINISH OPTIONS:

- 201** Polished Nickel w/ Matte Black Base
- W200** Modern Brass w/ Matte White Base
- W201** Polished Nickel w/ Matte White Base



S174



174

# Margeaux

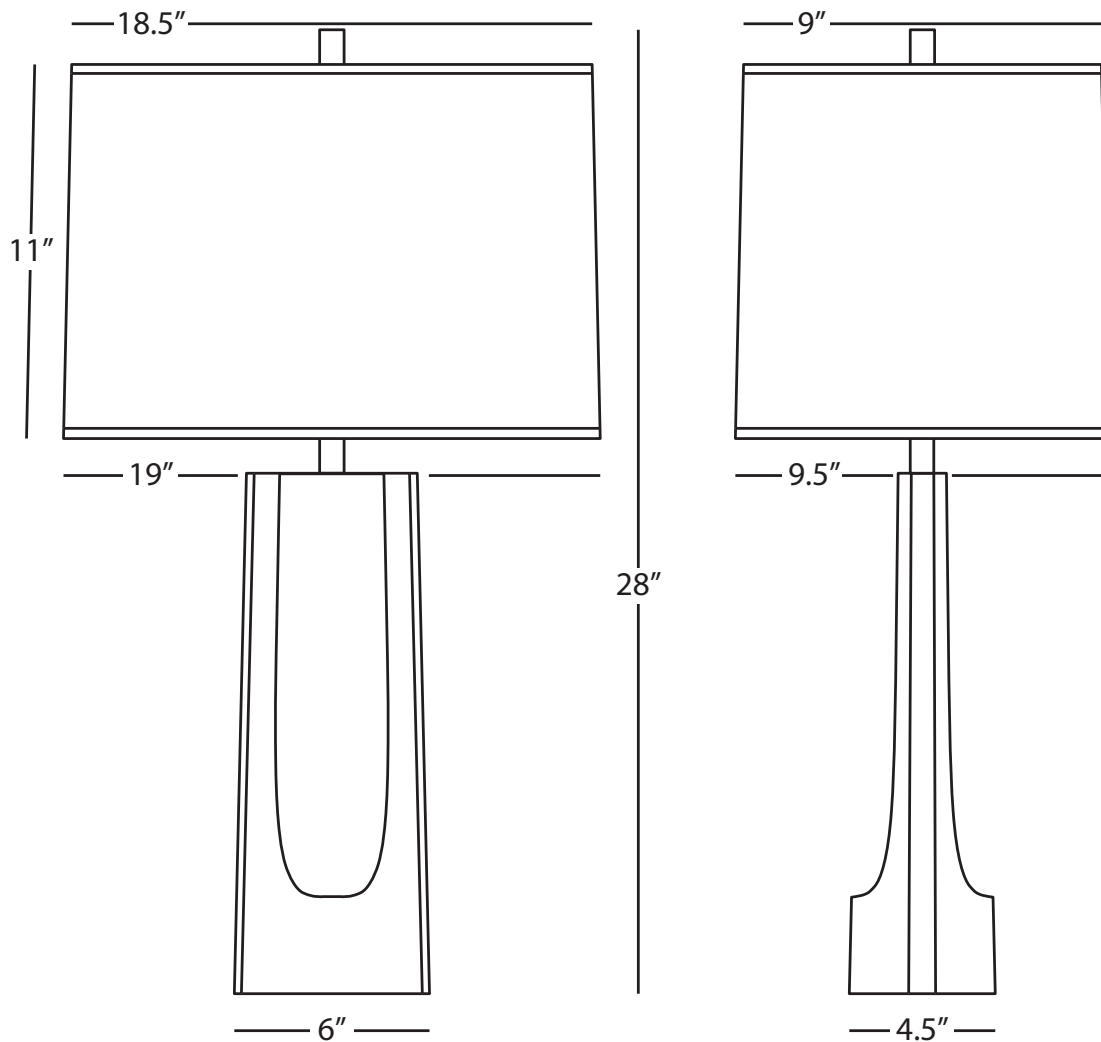

MARGEAUX

**174**

Table Lamp

1 - 100W Max.  
Bulb Type: A  
Switch: Full Range Dimmer  
Modern Brass Finish w/  
Brushed Modern Brass Accent  
White Oval Organza Shade

FINISH OPTION:

**S174** Polished and Brushed Nickel



CF960



979



G960



965



974



964



# Mason

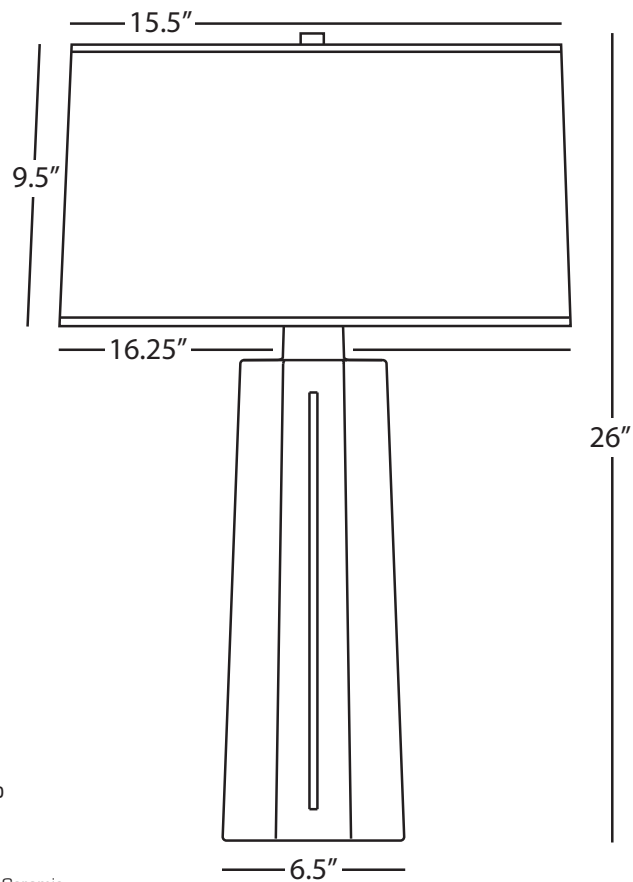
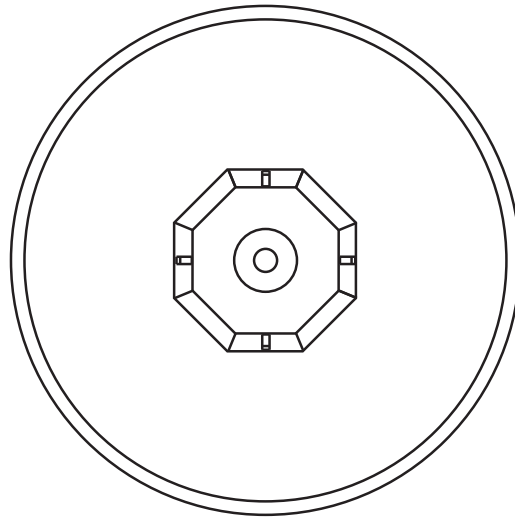

MASON

## 964 Table Lamp

1 - 150W Max.  
Bulb Type: A  
Switch: 3-Way  
Peacock Glazed Ceramic  
Polished Nickel Accents  
Oyster Linen Shade

See Page 234 for Color Options available w/ Oyster Linen Shade

### FINISH/SHADE OPTION:

**G960** Polished Gold Glazed Ceramic w/  
Polished Brass Accents  
White Ceramic Parchment Shade w/ Gold Mylar Lining



3314

# Muse

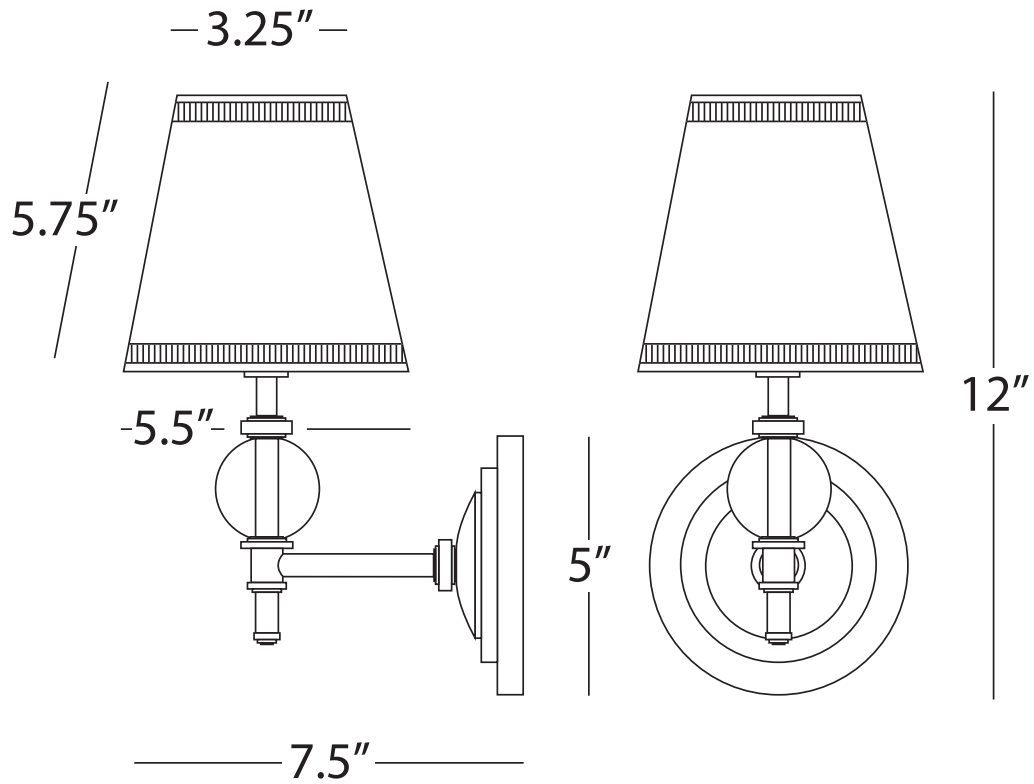

MUSE

## 3314 Wall Sconce

1 - 25W Max.  
Bulb Type: B10, Candelabra  
Direct Wire Only  
Lead Crystal w/ Silver Plated Accents  
White Mont Blanc Parchment  
Shade w/ Grosgrain Trim



S197



195



S195



S196

# Nikole

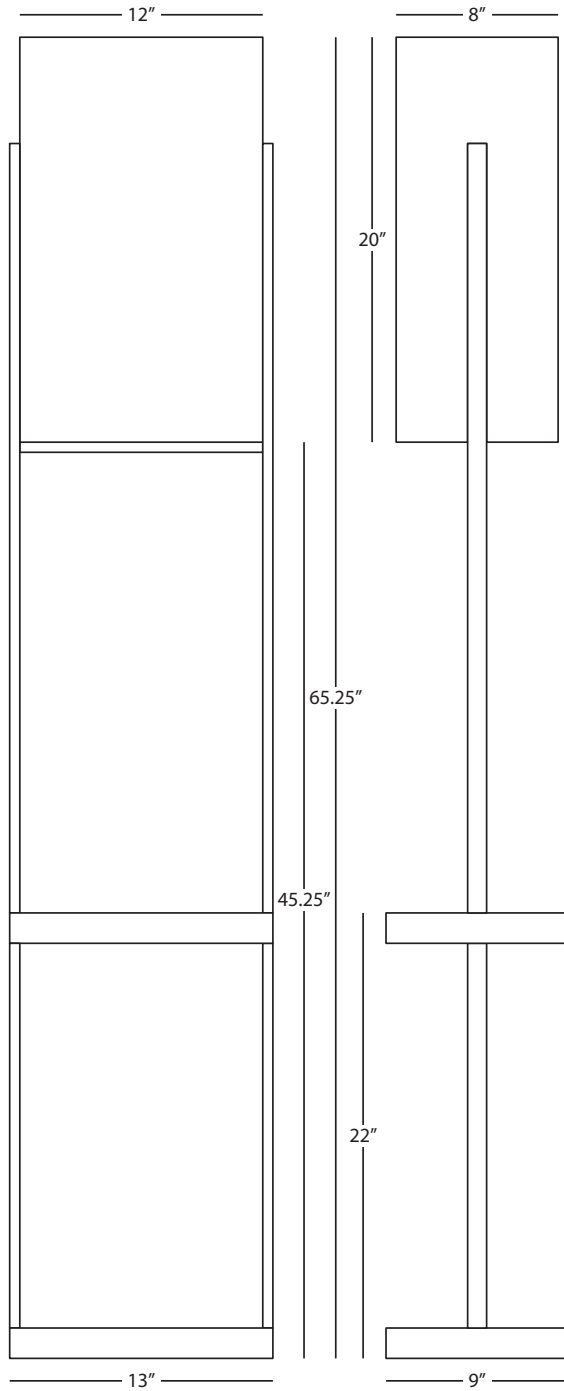

NIKOLE

## S197 Tray Table Floor Lamp

1 - 150W Max.  
Bulb Type: A  
Switch: Hi-Lo Dimming  
Polished Nickel Finish  
White Marble Base  
Clear Glass Tray  
Frosted, White Acrylic Shade

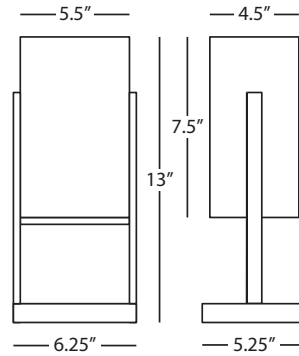

NIKOLE

## 195 Accent Lamp

1 - 60W Max.  
Bulb Type: B, Candelabra Base  
Switch: Hi-Lo Line Switch  
Modern Brass Finish  
White Marble Base  
Frosted, White Acrylic Shade

FINISH OPTION:  
**S195** Polished Nickel

NIKOLE

## S196 Table Lamp

1 - 150W Max.  
Bulb Type: A  
Switch: Hi-Lo Dimming  
Polished Nickel Finish  
White Marble Base  
Frosted, White Acrylic Shade

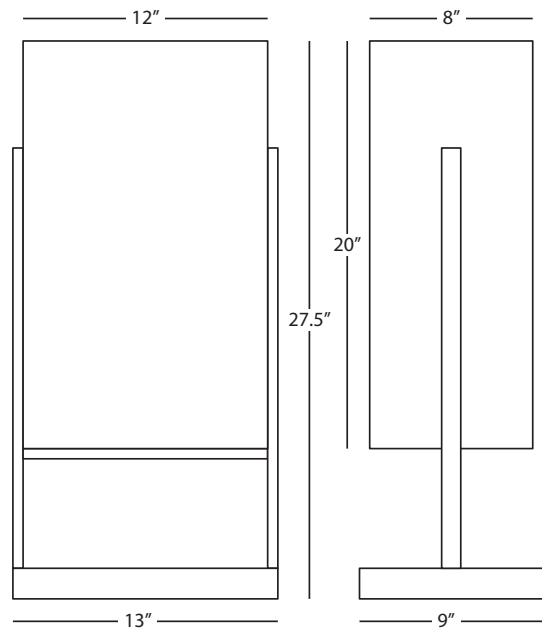



233



S232

# Nova

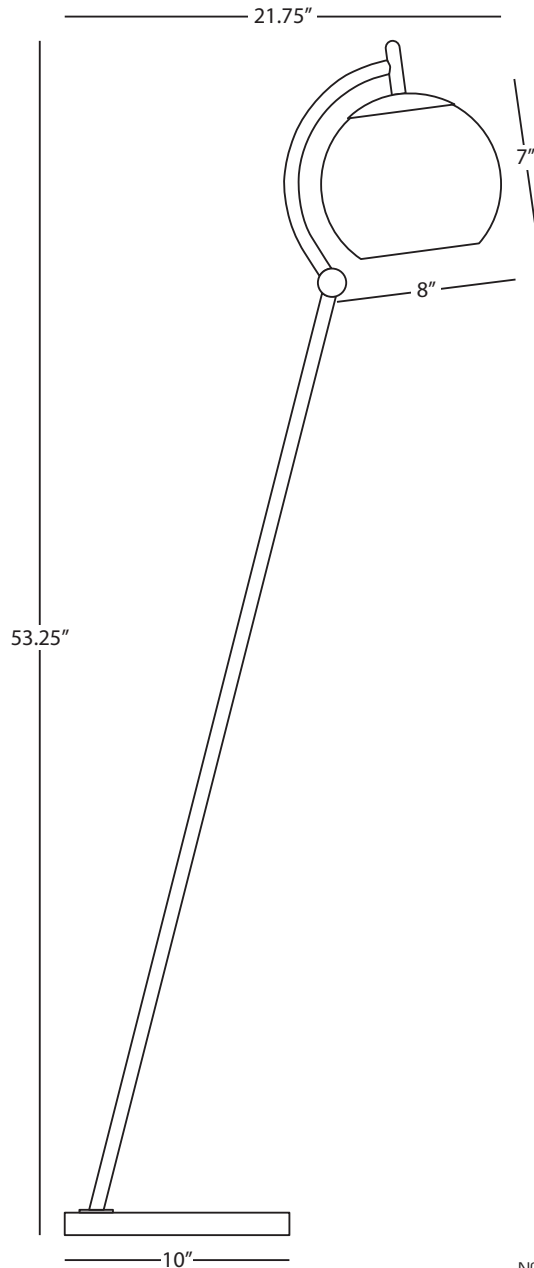

NOVA

## 233

### Floor Lamp

1 - 100W Max.  
Bulb Type: A  
Switch: Full Range Dimmer Foot Switch  
Modern Brass Finish  
White Cased Glass Shade

FINISH OPTION:  
**S233** Polished Nickel

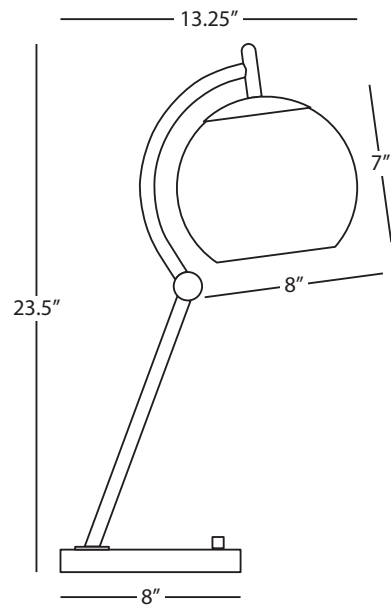

NOVA

## S232

### Table Lamp

1 - 100W Max.  
Bulb Type: A  
Switch: Full Range Dimmer  
Polished Nickel Finish  
White Cased Glass Shade  
USB Port on Base

FINISH OPTION:  
**232** Modern Brass



406B



S405



# Oculus

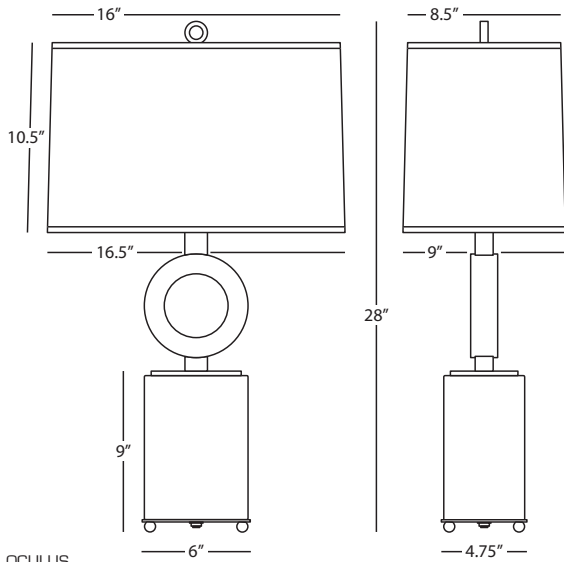

OCULUS

## S405

### Table Lamp

1 - 150W Max.  
 Bulb Type: A  
 Switch: Full Range Dimmer  
 Antique Silver Finish w/  
 White Marble Base  
 Rectangular Oyster Linen Shade

#### FINISH/SHADE OPTIONS:

- 405** Warm Brass/Oyster Linen
- 405B** Warm Brass/Black Painted Opaque  
Parchment Shade w/ White Lining
- S405B** Antique Silver/Black Painted Opaque  
Parchment Shade w/ White Lining

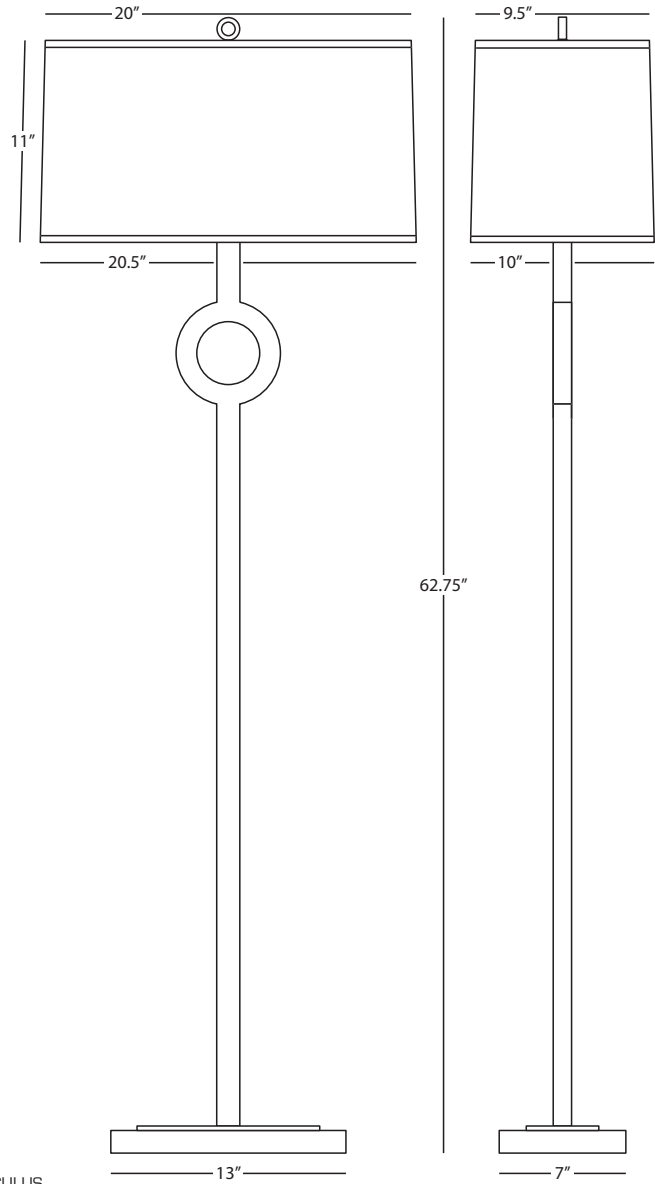

OCULUS

## 406B

### Floor Lamp

1 - 150W Max.  
 Bulb Type: A  
 Switch: Full Range Dimmer  
 Warm Brass Finish w/  
 White Marble Base  
 Rectangular Black Painted Opaque Parchment Shade  
 w/ White Lining

#### FINISH/SHADE OPTIONS:

- 406** Warm Brass/Oyster Linen
- S406** Antique Silver/Oyster Linen
- S406B** Antique Silver/Black Painted Opaque  
Parchment Shade w/ White Lining



829



828

# Oliver

OLIVER

## 829 Swing Arm Sconce

1 - 60W Max.  
Bulb Type: B, Candelabra  
Switch: On-Off Line Switch  
24" Cord Cover/Direct Wire  
Unfinished Mango Wood w/  
Patina Nickel Accents  
Open Weave Heather Linen Shade

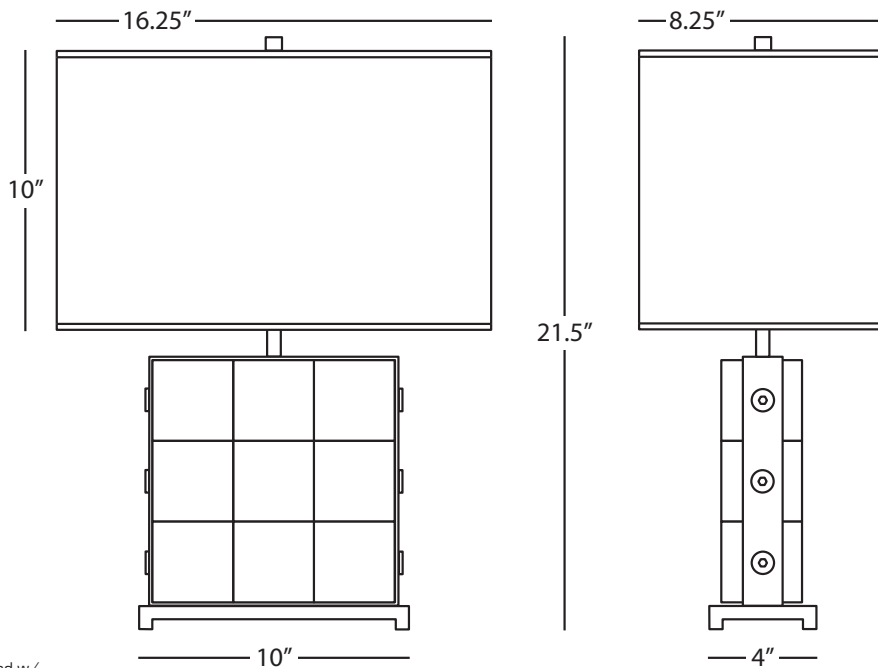
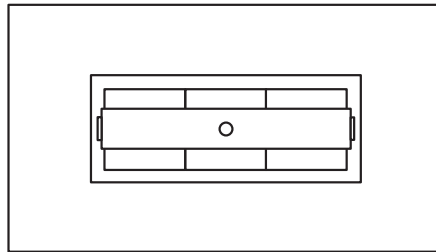
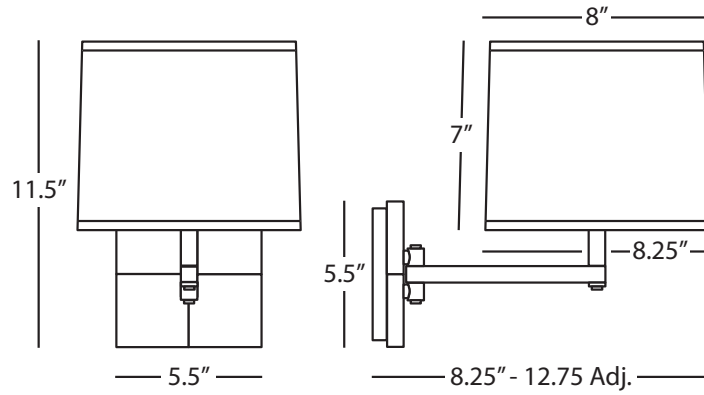

OLIVER

## 828 Table Lamp

1 - 150W Max.  
Bulb Type: A  
Switch: Hi-Lo Dimming  
Unfinished Mango Wood w/  
Patina Nickel Accents  
Rectangular Open Weave Heather Linen Shade



BB999



PC999

MCR18

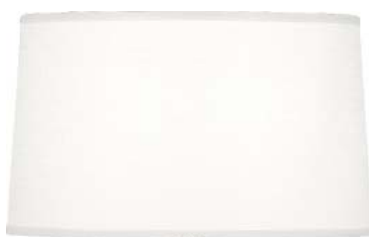

CI999

BN989

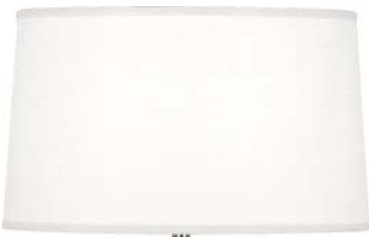

MCL17

# Orion

ORION

## BN989

### Accent Lamp

1 - 60W Max.  
Bulb Type: B, Candelabra  
Switch: Hi-Lo Line Switch  
Bone Glazed Ceramic  
Oyster Linen Shade w/  
Self-Fabric Top Diffuser

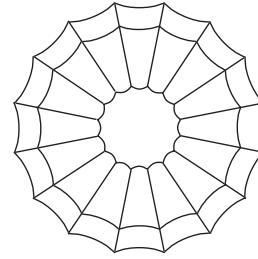

See Page 235 for Color Options

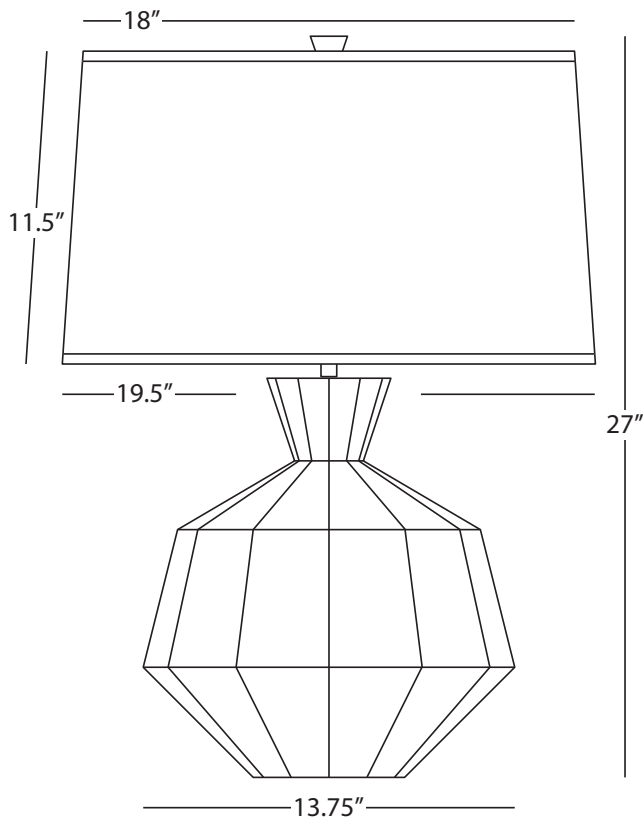
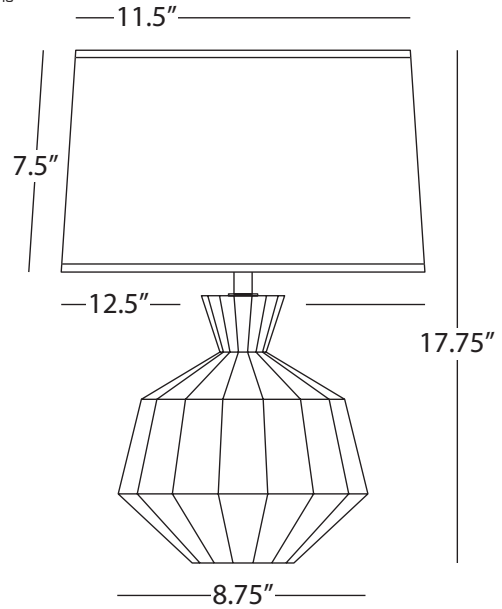
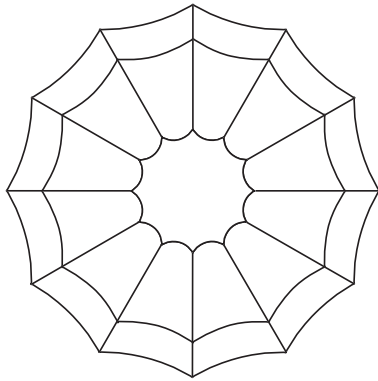

ORION

## BB999

### Table Lamp

1 - 150W Max.  
Bulb Type: A  
Switch: Hi-Lo Dimming  
Baby Blue Glazed Ceramic  
Oyster Linen Shade  
Self-Fabric Top Diffuser

See Page 235 for Color Options



LY44X



ST45X



ST44



MB45

# Pearl

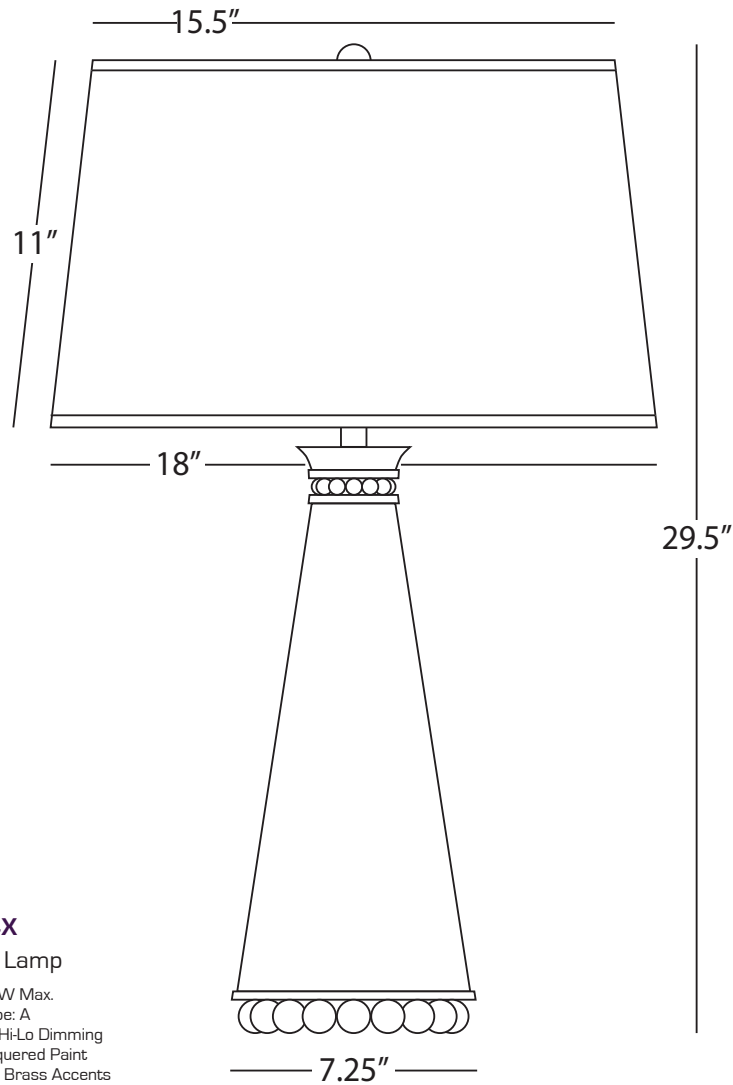

PEARL

## LY44X

### Table Lamp

1 - 150W Max.  
 Bulb Type: A  
 Switch: Hi-Lo Dimming  
 Lily Lacquered Paint  
 Modern Brass Accents  
 Fondine Fabric Shade

#### FINISH/SHADE OPTIONS:

- LY44** Lily Lacquered Paint w/ Modern Brass Accents  
Lily Painted Opaque Parchment w/ Gold Lining
- LY45** Lily Lacquered Paint w/ Polished Nickel Accents  
Lily Painted Opaque Parchment w/ Silver Lining
- LY45X** Lily Lacquered Paint w/ Polished Nickel Accents  
Fondine Fabric Shade
- MB44** Midnight Blue Lacquered Paint w/ Modern Brass Accents  
Midnight Blue Painted Opaque Parchment w/ Gold Lining
- MB44X** Midnight Blue Lacquered Paint w/ Modern Brass Accents  
Fondine Fabric Shade
- MB45** Midnight Blue Lacquered Paint w/ Polished Nickel Accents  
Midnight Blue Painted Opaque Parchment w/ Silver Lining
- MB45X** Midnight Blue Lacquered Paint w/ Polished Nickel Accents  
Fondine Fabric Shade
- ST44** Smoky Taupe Lacquered Paint w/ Modern Brass Accents  
Smoky Taupe Painted Opaque Parchment w/ Gold Lining
- ST44X** Smoky Taupe Lacquered Paint w/ Modern Brass Accents  
Fondine Fabric Shade
- ST45** Smoky Taupe Lacquered Paint w/ Polished Nickel Accents  
Smoky Taupe Painted Opaque Parchment w/ Silver Lining
- ST45X** Smoky Taupe Lacquered Paint w/ Polished Nickel Accents  
Fondine Fabric Shade



595



596



# Peek

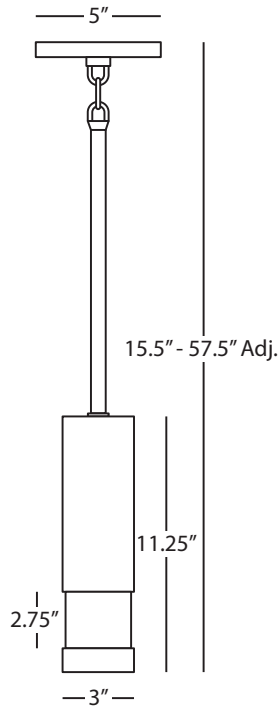

PEEK

## 595

### Pendant

1 - 60W Max.  
Bulb Type: B, Medium Base  
Direct Wire  
Polished Aluminum Finish  
Cased White Glass Shade  
Susp. Hardware: 1 pc. 5/8" x 6" & 3 pcs.  
5/8" x 12" Extensions

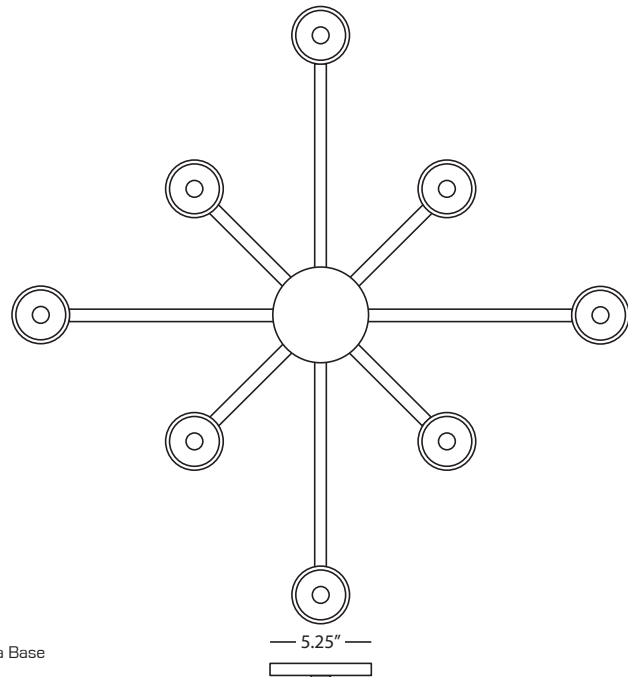

PEEK

## 596

### Chandelier

16 - 60W Max.  
Bulb Type: B, Candelabra Base  
Direct Wire  
Polished Aluminum Finish  
Cased White Glass Shades  
Susp. Hardware: 1 pc. 5/8" x 6" &  
3 pcs. 5/8" x 12" Extensions

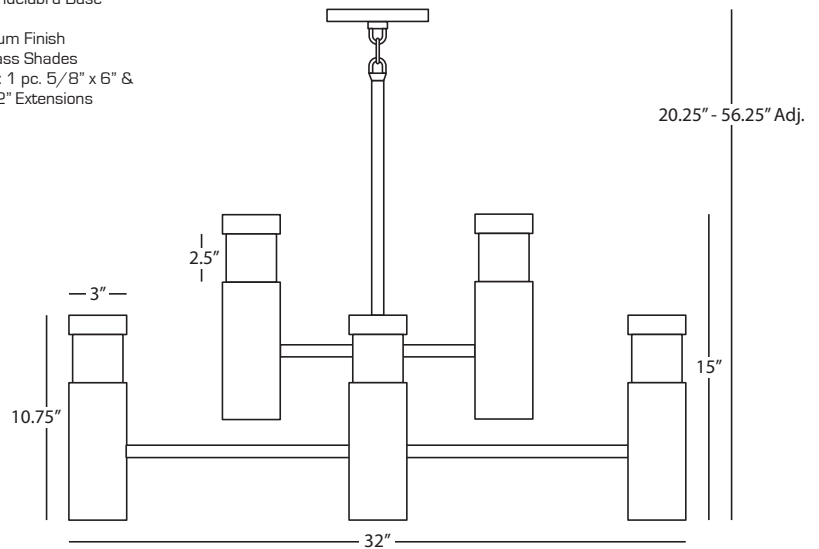



A808



F808



O808



N808



T808

# Penelope

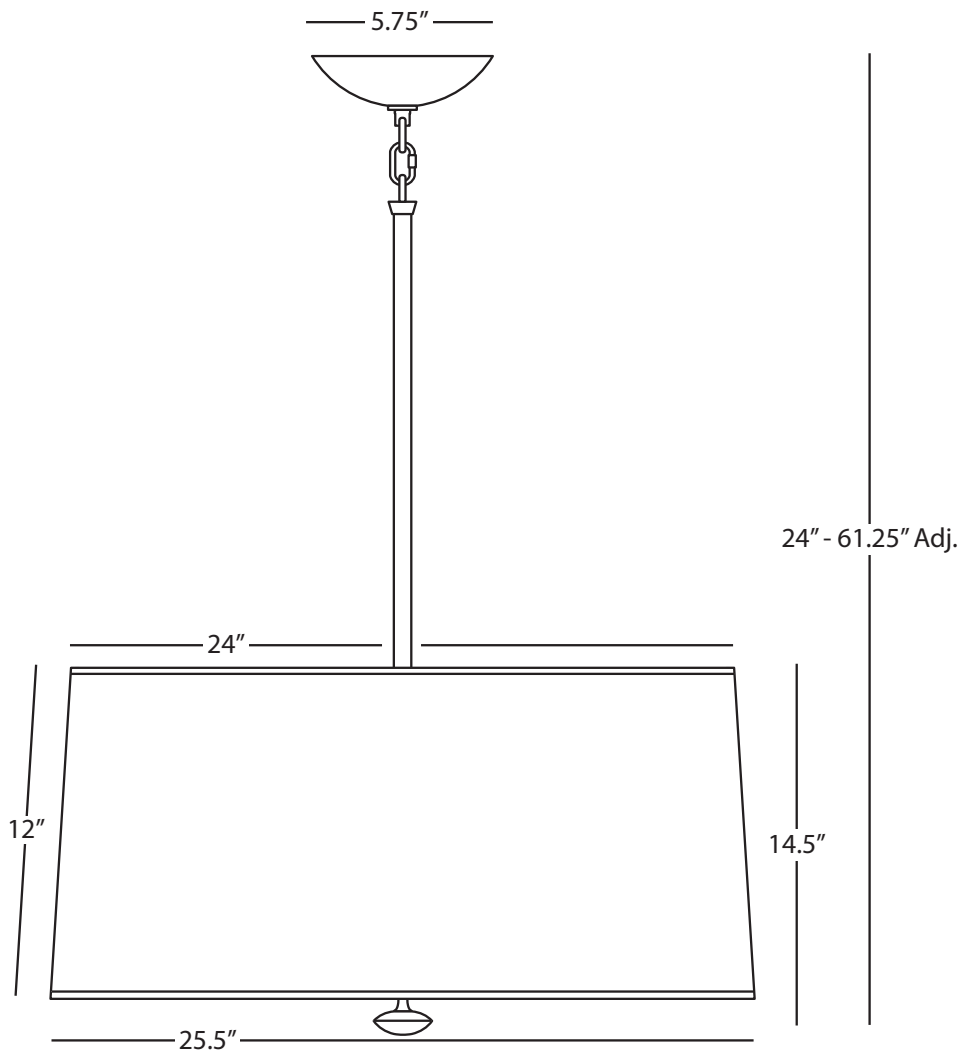

PENELOPE

## N808

### Pendant

3 - 100W Max.  
Bulb Type: A  
Direct Wire Only  
Polished Nickel Finish  
Lead Crystal Finial  
Navy Ceramic Parchment Shade w/ Silver Mylar Lining  
13.25" Dia. Polished Nickel Finished Metal Diffuser Included  
Susp. Hardware: 3 pcs. 5/8" x 12" & 1 pc. 5/8" x 6" Extensions

#### SHADE OPTIONS:

- A808** Ascot White Fabric Shade
- B808** Black Ceramic Parchment w/ Silver Mylar Lining
- F808** Fuchsia Ceramic Parchment w/ Silver Mylar Lining
- O808** Orange Ceramic Parchment w/ Silver Mylar Lining
- R808** Red Ceramic Parchment w/ Silver Mylar Lining
- S808** Silver Mylar w/ White Ceramic Parchment Lining
- T808** Taupe Ceramic Parchment w/ Silver Mylar Lining
- W808** White Ceramic Parchment w/ Silver Mylar Lining



G808

# Penelope

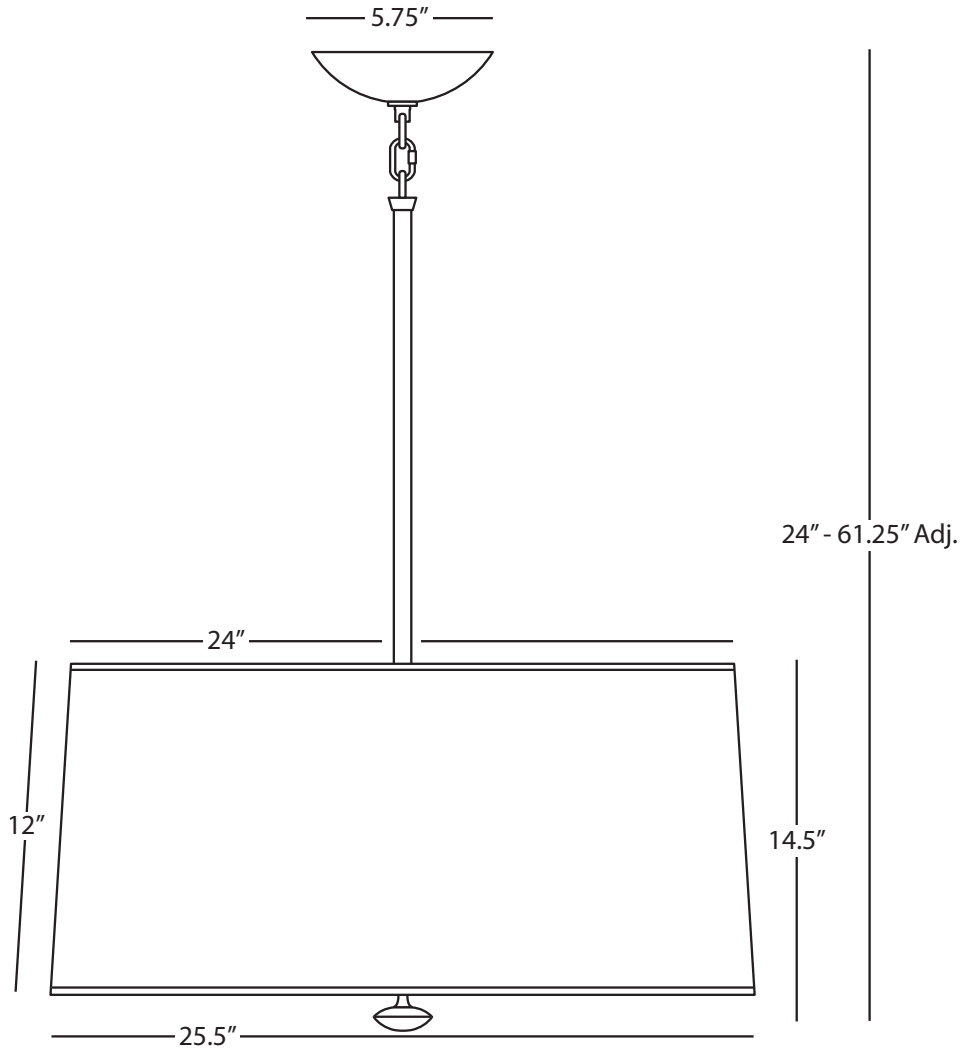

PENELOPE

## G808

### Pendant

3 - 100W Max.  
Bulb Type: A  
Direct Wire Only  
Polished Brass Finish  
Lead Crystal Finial  
White Ceramic Parchment Shade  
w/ Gold Mylar Lining  
13.25" Polished Brass Finished  
Metal Diffuser Included  
Susp. Hardware: 3 pcs. 5/8" x 12"  
& 1 pc. 5/8" x 6" Extensions



870



870C



871



874X



873



876

# Phoebe

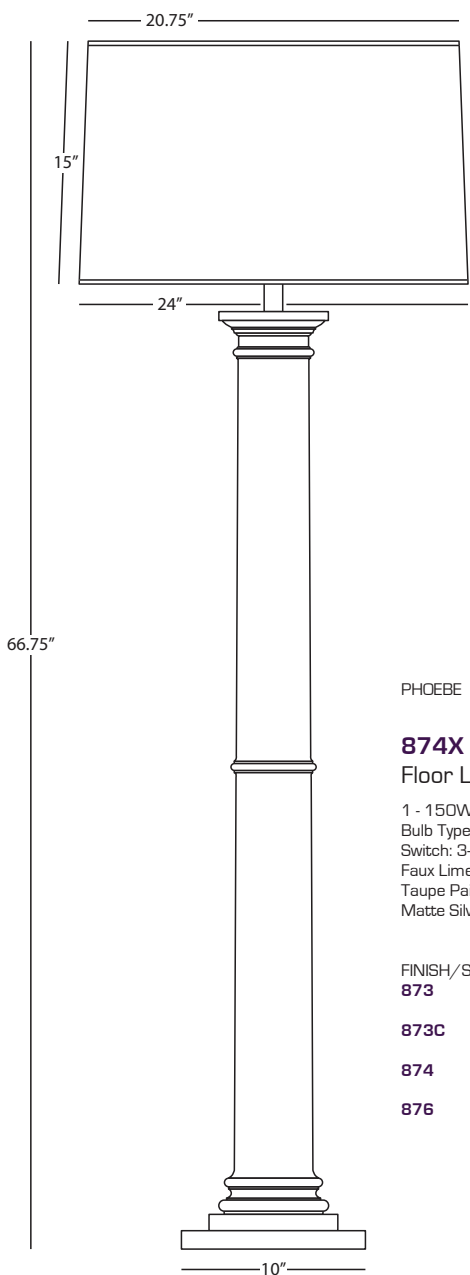
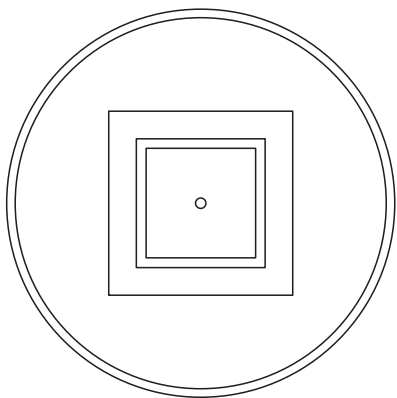

PHOEBE

## 874X Floor Lamp

1 - 150W Max.  
Bulb Type: A  
Switch: 3-Way  
Faux Limestone Painted Finish over Poly Resin  
Taupe Painted Opaque Parchment Shade w/  
Matte Silver Lining

FINISH/SHADE OPTIONS:

- 873** Matte White Painted Finish  
White Brussels Linen Shade
- 873C** Matte White Painted Finish  
Chocolate Painted Opaque Parchment Shade
- 874** Faux Limestone Painted Finish  
Oyster Linen Shade
- 876** Faux Concrete Painted Finish  
Translucent White Monte Blanc Parchment Shade

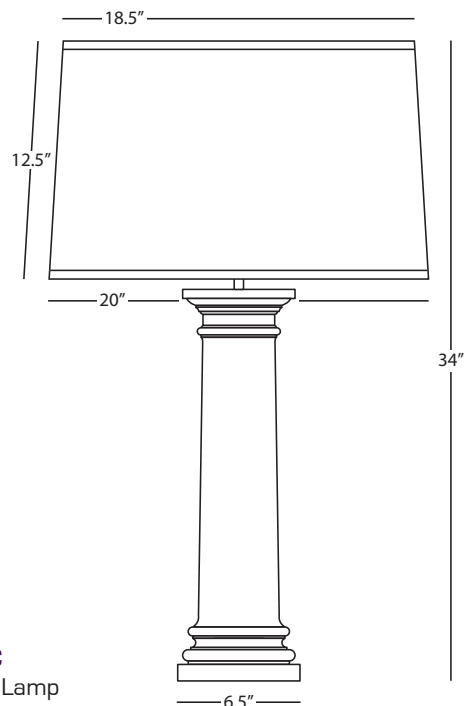

PHOEBE

## 870C Table Lamp

1 - 150W Max.  
Bulb Type: A  
Switch: 3-Way  
Matte White Painted Finish over Poly Resin  
Chocolate Painted Opaque Parchment Shade  
w/ Matte Silver Lining

FINISH/SHADE OPTIONS:

- 870** Matte White Painted Finish  
White Brussels Linen Shade
- 871** Faux Limestone Painted Finish  
Oyster Linen Shade
- 871X** Faux Limestone Painted Finish  
Taupe Painted Opaque  
Parchment Shade
- 872** Faux Concrete Painted Finish  
Translucent White Monte Blanc  
Parchment Shade

# Phoebe Al Fresco



JV453



WZ49R



JV49G



WZ50G



JV50R



WZ454



# Phoebe Al Fresco

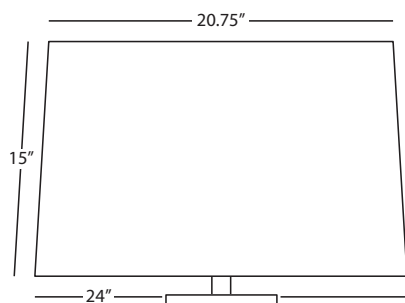
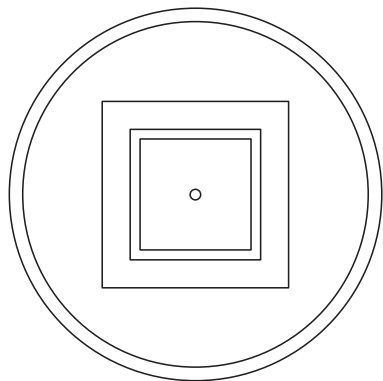

66.75"

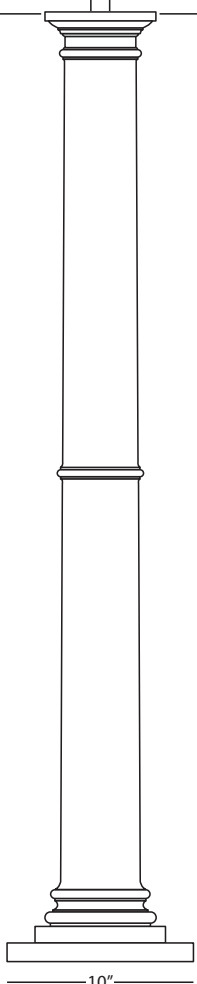

10"

PHOEBE AL FRESCO

## JV50R Outdoor Floor Lamp

1 - 100W Max.  
Bulb Type: A  
Switch: On-Off  
Java Brown Painted Finish over Poly Resin  
Orange Jacquard Sunbrella Fabric Shade Cover  
UL Rated Wet Location

FINISH/SHADE OPTIONS:

- JV454** Java Brown  
White Sunbrella Fabric
- JV50G** Java Brown  
Gray Jacquard Sunbrella Fabric
- WZ454** Weathered Zinc  
White Sunbrella Fabric
- WZ50G** Weathered Zinc  
Gray Jacquard Sunbrella Fabric
- WZ50R** Weathered Zinc  
Orange Jacquard Sunbrella Fabric

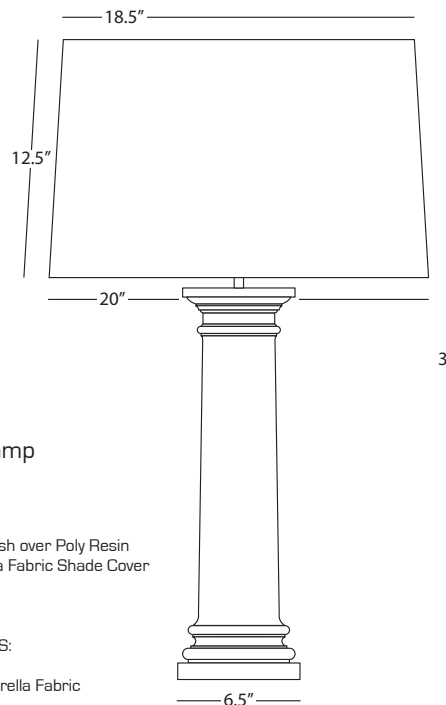

PHOEBE AL FRESCO

## JV49G Outdoor Table Lamp

1 - 100W Max.  
Bulb Type: A  
Switch: On-Off  
Java Brown Painted Finish over Poly Resin  
Gray Jacquard Sunbrella Fabric Shade Cover  
UL Rated Wet Location

FINISH/SHADE OPTIONS:

- JV453** Java Brown  
White Sunbrella Fabric
- JV49R** Java Brown  
Orange Jacquard Sunbrella Fabric
- WZ453** Weathered Zinc  
White Sunbrella Fabric
- WZ49G** Weathered Zinc  
Gray Jacquard Sunbrella Fabric
- WZ49R** Weathered Zinc  
Orange Jacquard Sunbrella Fabric

| Pierce

---



# Pierce

---

[Click photo above to watch Pierce Table Lamp video](#)

Sleek and contemporary, Pierce's perforated surfaces allow pinpoints of light to shine through for an enchanting effect. We've added brilliant pops of color to this collection for October 2020 by introducing canary yellow, pumpkin, egg blue, and ruby red to the Pierce table lamp and new task lamp.

---



980



S980



CY780



EB780



RR780



PM780



PB780

# Pierce

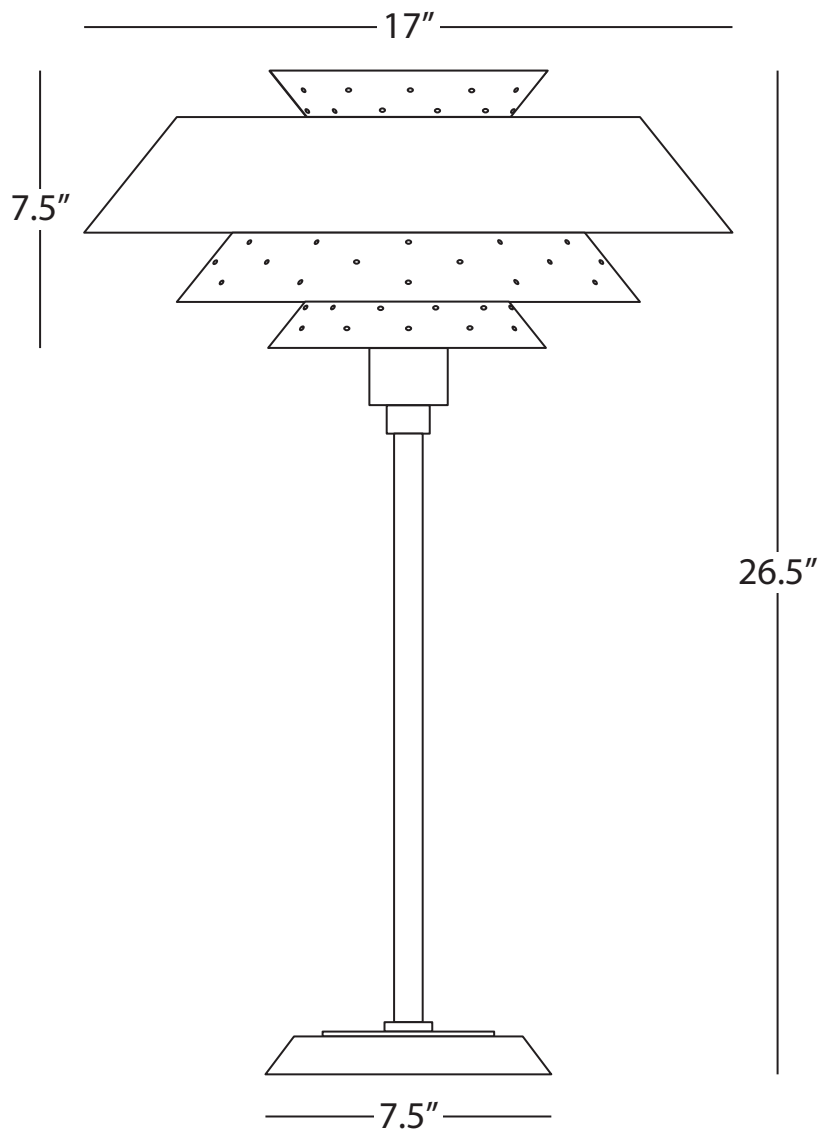

PIERCE

**980**

Table Lamp

1 - 150W Max.  
Bulb Type: A  
Switch: Full Range Dimmer Line Switch  
Modern Brass Finish  
Perforated Metal Shade w/ White Interior

FINISH OPTIONS:

<b>CY780</b>	Canary Yellow Gloss
<b>EB780</b>	Egg Blue Gloss
<b>PB780</b>	Piano Black Gloss
<b>PM780</b>	Pumpkin Gloss
<b>RR780</b>	Ruby Red Gloss
<b>SS80</b>	Antique Silver

# Pierce



# Pierce

---

[Click photo above to watch Pierce Task Table Lamp video](#)

Sleek and contemporary, Pierce's perforated surfaces allow pinpoints of light to shine through for an enchanting effect. We've added brilliant pops of color to this collection for October 2020 by introducing canary yellow, pumpkin, egg blue, and ruby red to the Pierce table lamp and new task lamp.

---



CY988



RR988



EB988



PM988



PB988



# Pierce

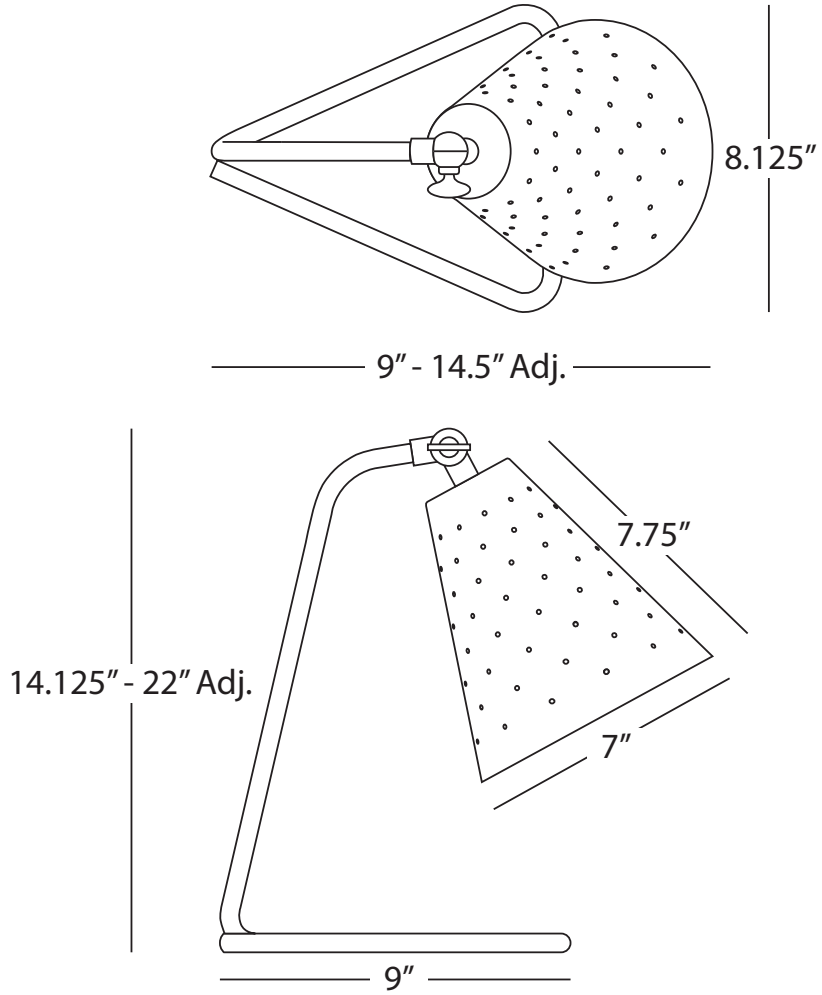

PIERCE

## CY988

### Task Table Lamp

1 - 60W Max.  
Bulb Type: A  
Switch: Full Range Dimmer Line Switch  
Canary Yellow Gloss Finish  
Perforated Metal Shade w/ White Interior

#### FINISH OPTIONS:

<b>988</b>	Modern Brass
<b>EB988</b>	Egg Blue Gloss
<b>PB988</b>	Piano Black Gloss
<b>PM988</b>	Pumpkin Gloss
<b>RR988</b>	Ruby Red Gloss
<b>S988</b>	Antique Silver



S981



983



984



S982

# Pierce

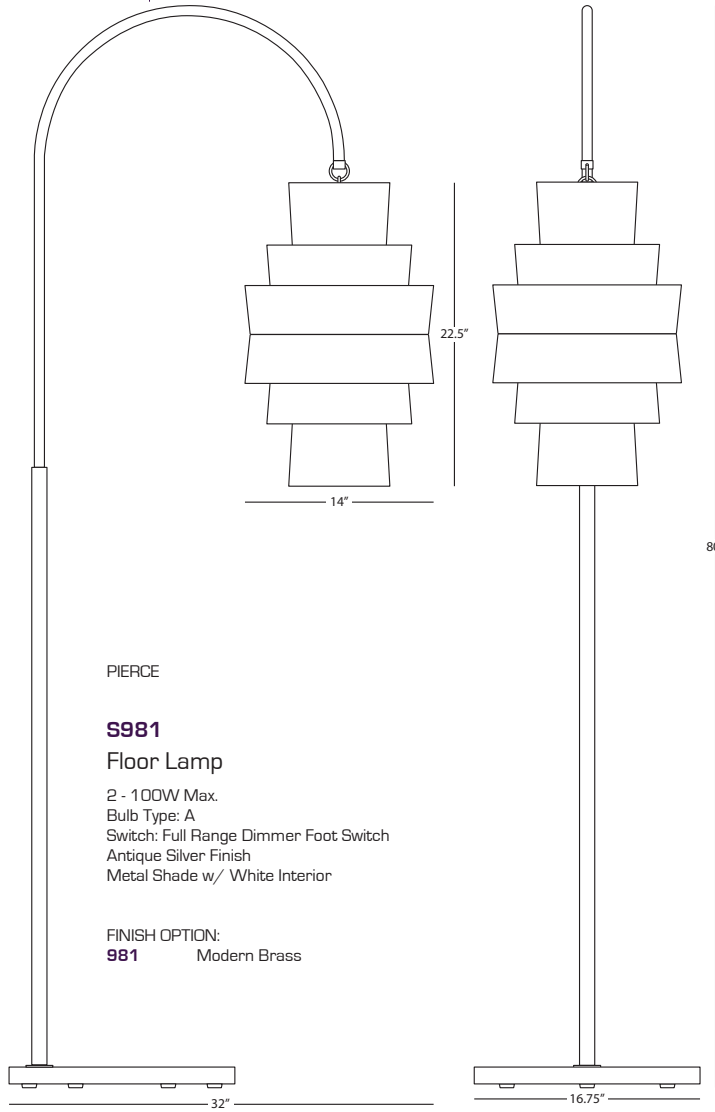

PIERCE

## S981 Floor Lamp

2 - 100W Max.  
Bulb Type: A  
Switch: Full Range Dimmer Foot Switch  
Antique Silver Finish  
Metal Shade w/ White Interior

FINISH OPTION:  
**981** Modern Brass

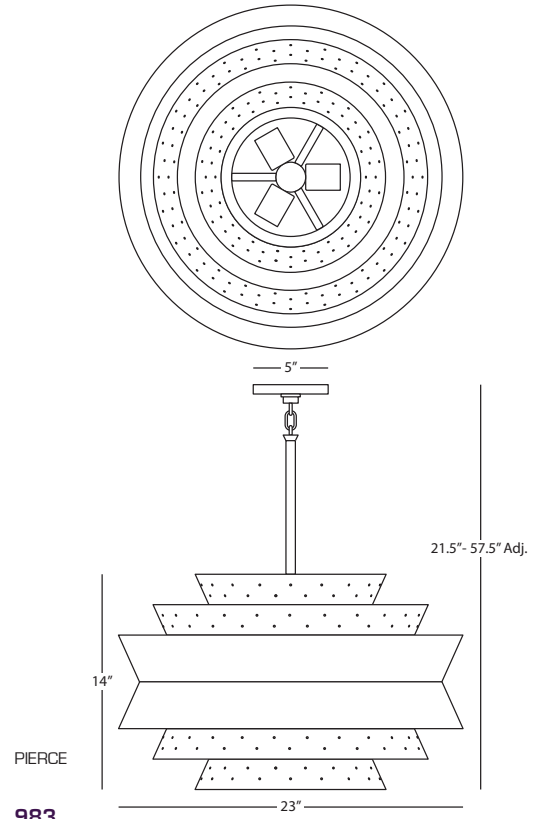

PIERCE

## 983 Large Pendant

3 - 60W Max.  
Bulb Type: B, Medium Base  
Direct Wire  
Modern Brass Finish  
Perforated Metal Shade w/  
White Interior  
Susp. Hardware: 3 pcs. 5/8" x 12"  
& 1 pc. 5/8" x 6" Extensions

FINISH OPTION:  
**S983** Antique Silver

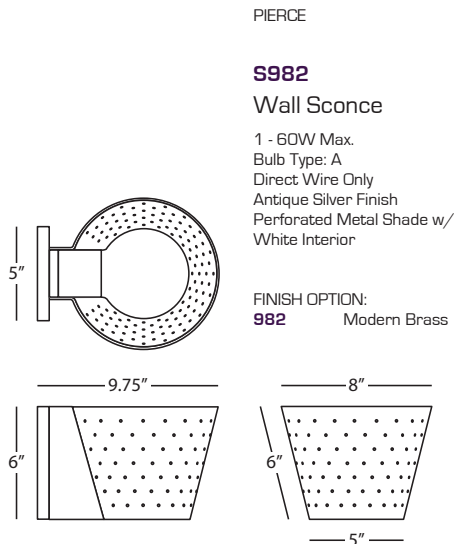

PIERCE

## S982 Wall Sconce

1 - 60W Max.  
Bulb Type: A  
Direct Wire Only  
Antique Silver Finish  
Perforated Metal Shade w/  
White Interior

FINISH OPTION:  
**982** Modern Brass

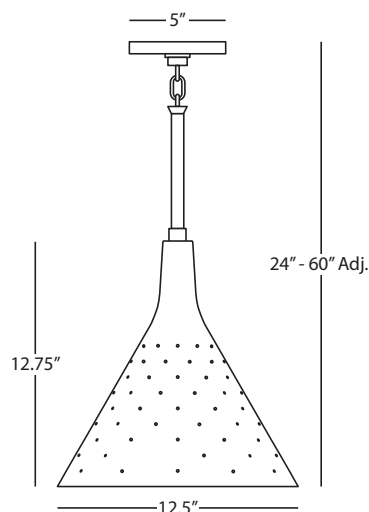

PIERCE

## 984 Pendant

1 - 100W Max.  
Bulb Type: A  
Direct Wire  
Modern Brass Finish  
Perforated Metal Shade w/  
White Interior  
Susp. Hardware: 3 pcs. 5/8" x 12"  
& 1 pc. 5/8" x 6" Extensions

FINISH OPTION:  
**S984** Antique Silver



CI996



PC996



TE994



SU994



ST994

# Pike

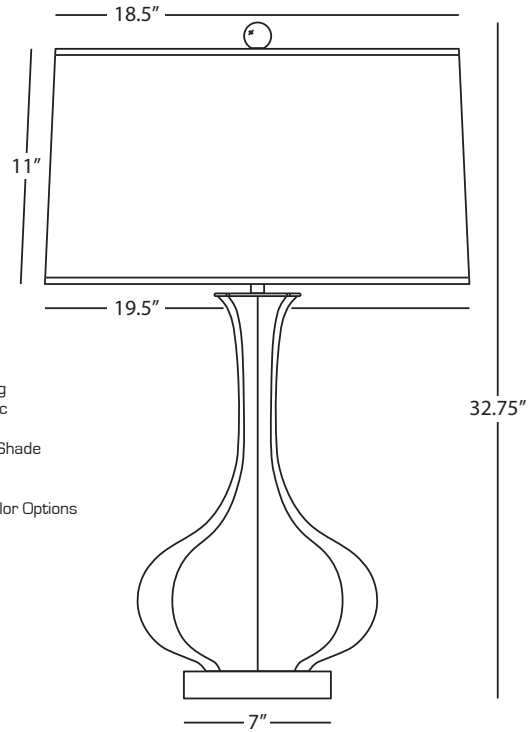
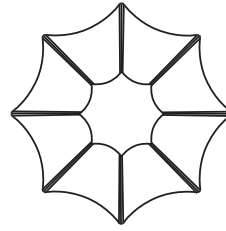

PIKE

## CI996

### Table Lamp

1 - 150W Max.  
Bulb Type: A  
Switch: Hi-Lo Dimming  
Citron Glazed Ceramic  
Lucite Base  
Pearl Dupioni Fabric Shade

See Page 236 for Color Options

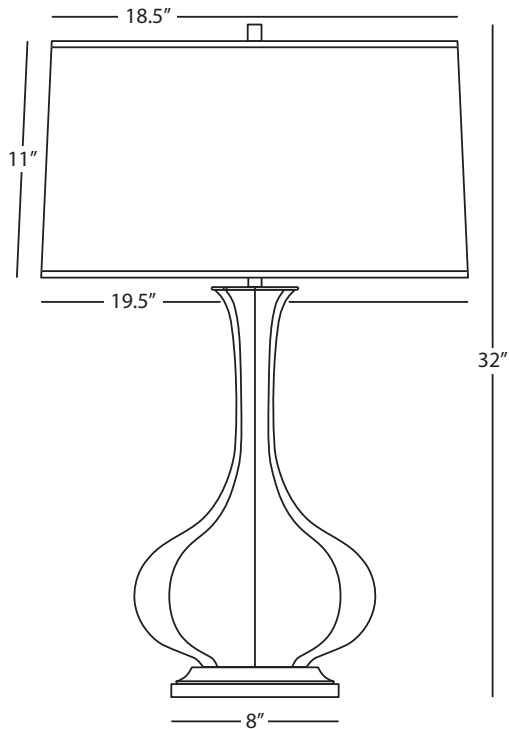
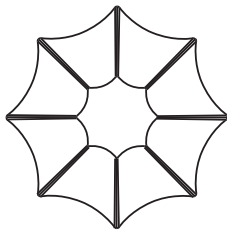

PIKE

## ST994

### Table Lamp

1 - 150W Max.  
Bulb Type: A  
Switch: Hi-Lo Dimming  
Smoky Taupe Glazed Ceramic  
Aged Brass Accents  
Pearl Dupioni Fabric Shade

See Page 236 for Color Options



# Plexus

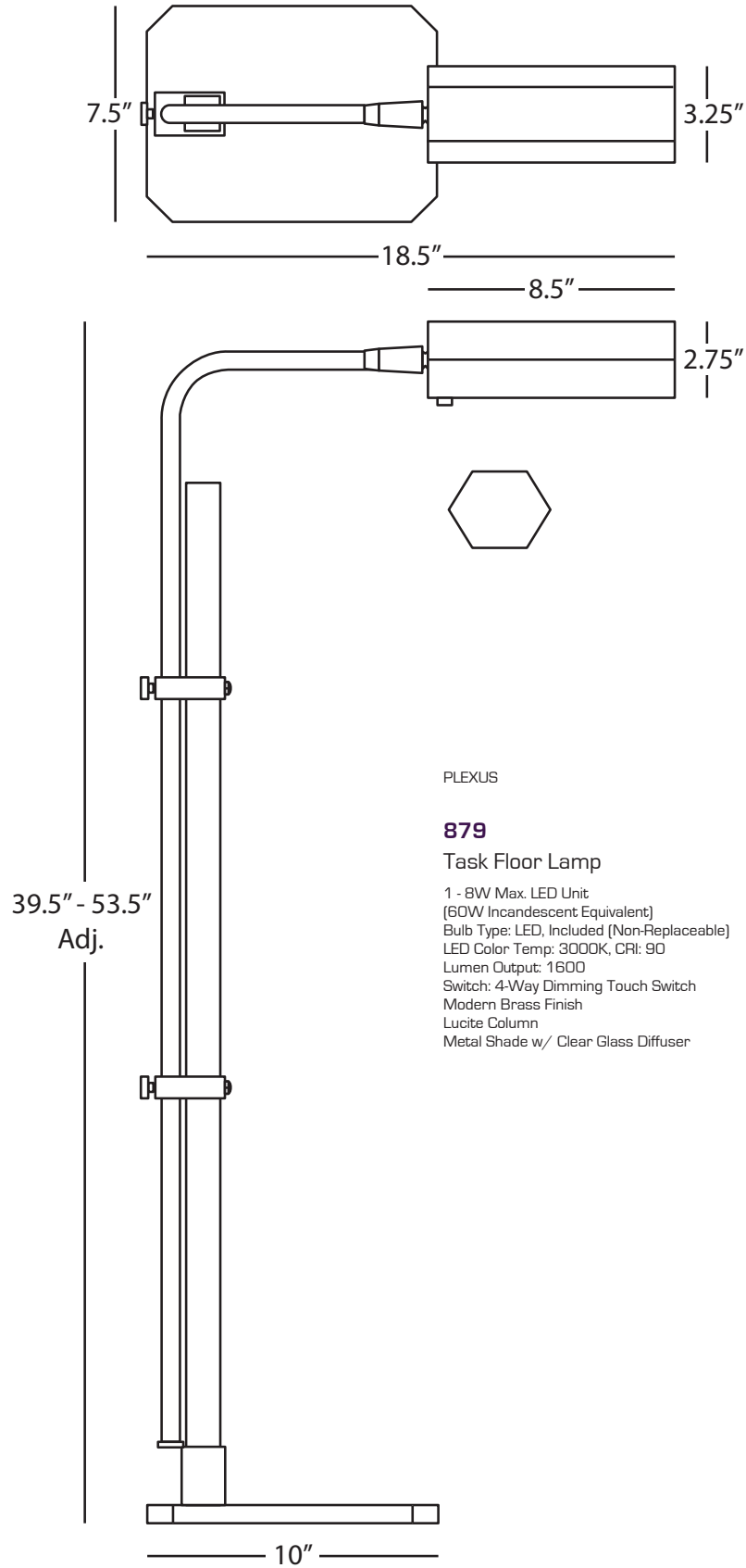



1445



1446



1444



1447



# Ranger

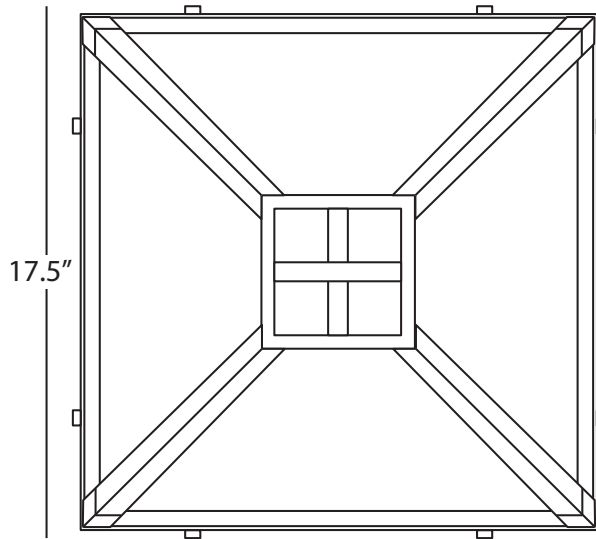

— 5.25" —

RANGER

## 1444

Pendant

3 - 60W Max.  
Bulb Type: A  
Direct Wire  
Matte Black Painted Finish w/  
Modern Brass Accents  
Square, Printed White Glass Diffuser  
Susp. Hardware: 3 Ft. Chain

FINISH OPTIONS:

- 1445** Glossy White w/ Modern Brass Accents
- 1446** Matte Black w/ Polished Nickel Accents
- 1447** Glossy White w/ Polished Nickel Accents

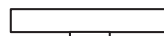

21.5" - 59.5" Adj.

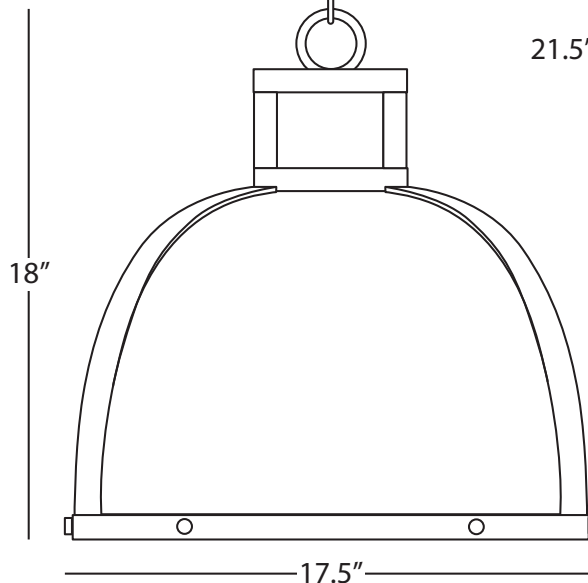



480



483



483X

# Raquel

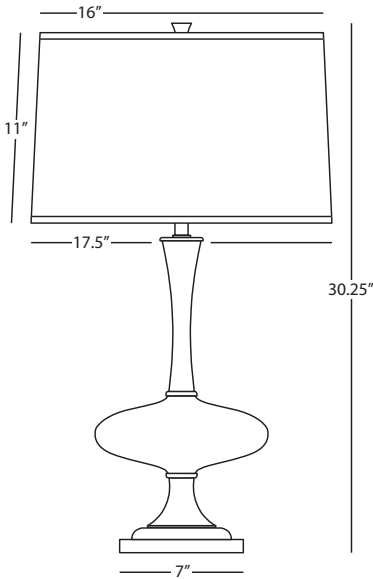
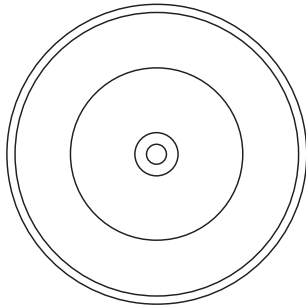

RAQUEL

## 483X

### Oval Table Lamp

1 - 150W Max.  
Bulb Type: A  
Switch: Hi-Lo Dimming  
White Glass w/ Modern Brass  
and Carrara Marble Accents  
Oval Pearl Dupioni Fabric Shade

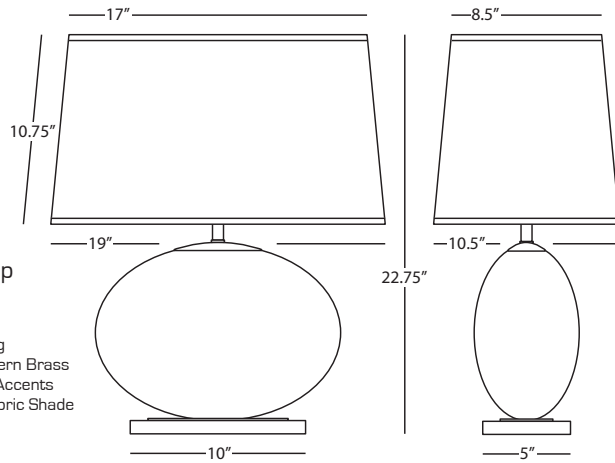

RAQUEL

## 480

### Table Lamp

1 - 150W Max.  
Bulb Type: A  
Switch: Hi-Lo Dimming  
White Glass w/ Modern Brass  
and Carrara Marble Accents  
Pearl Dupioni Fabric Shade

RAQUEL

## 483

### Oval Table Lamp

1 - 150W Max.  
Bulb Type: A  
Switch: Hi-Lo Dimming  
White Glass w/ Modern Brass  
and Carrara Marble Accents  
Tall Oval Pearl Dupioni Fabric Shade

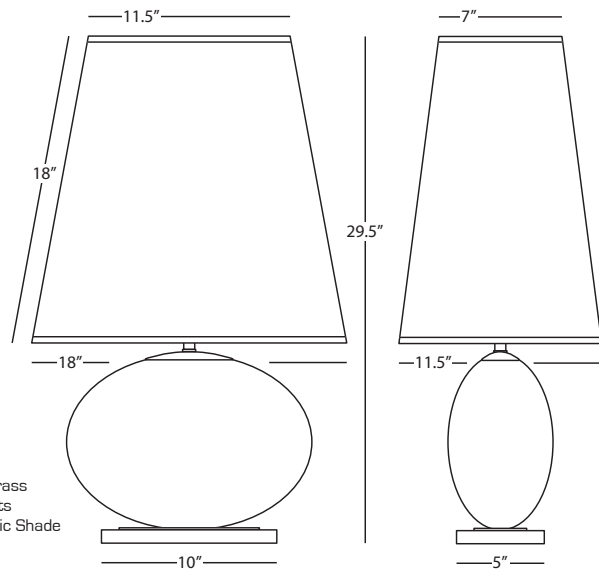



1833



1824



1802



Z1815

# Real Simple

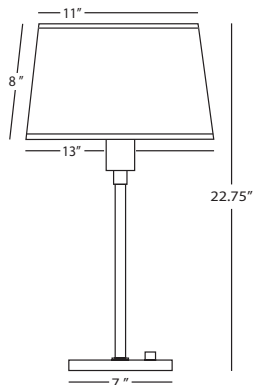

REAL SIMPLE

## 1802 Club Table Lamp

1 - 100W Max.  
Bulb Type: A  
Switch: Hi-Lo Base Switch  
Stardust White Powder Coat Finish  
White Mont. Blanc Parchment Shade  
w/ Self-Fabric Top Diffuser

FINISH/SHADE OPTIONS:

- Z1812** Dark Bronze  
Snowflake Fabric
- 1822** Gunmetal  
Snowflake Fabric
- 1832** Matte Black  
Snowflake Fabric

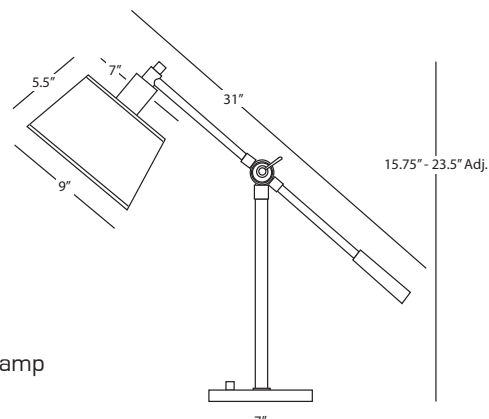

REAL SIMPLE

## 1833 Boom Table Lamp

1 - 100W Max.  
Bulb Type: A  
Switch: Hi-Lo Base Switch  
Matte Black Powder Coat Finish  
Snowflake Fabric Shade w/ Self-Fabric Top Diffuser

FINISH/SHADE OPTIONS:

- 1803** Stardust White  
White Mont. Blanc Parchment
- Z1813** Dark Bronze  
Snowflake Fabric
- 1823** Gunmetal  
Snowflake Fabric

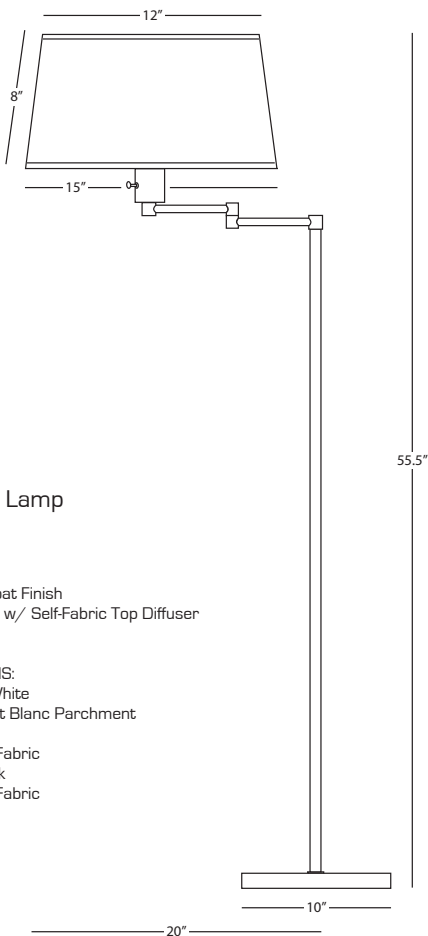

REAL SIMPLE

## Z1815 Swing Arm Floor Lamp

1 - 150W Max.  
Bulb Type: A  
Switch: 3-Way  
Dark Bronze Powder Coat Finish  
Snowflake Fabric Shade w/ Self-Fabric Top Diffuser

FINISH/SHADE OPTIONS:

- 1805** Stardust White  
White Mont. Blanc Parchment
- 1825** Gunmetal  
Snowflake Fabric
- 1835** Matte Black  
Snowflake Fabric

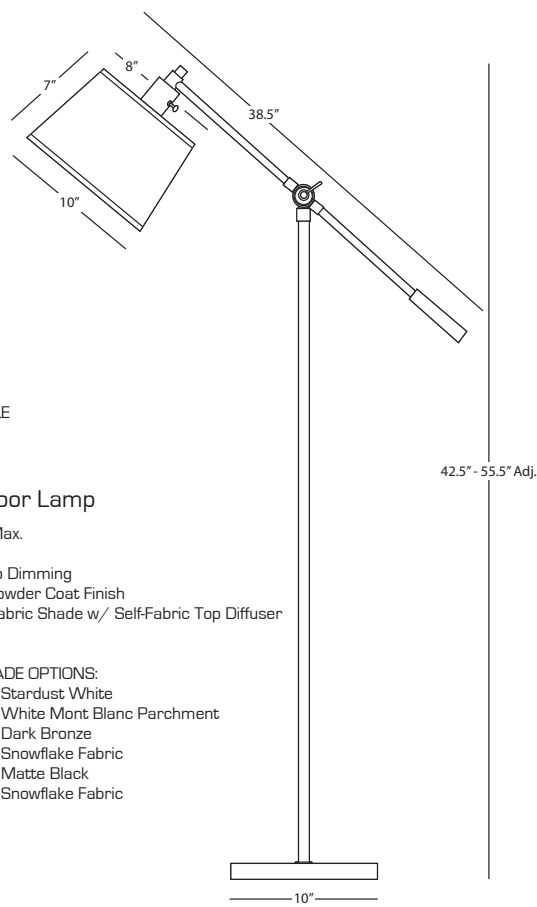

REAL SIMPLE

## 1824 Boom Floor Lamp

1 - 100W Max.  
Bulb Type: A  
Switch: Hi-Lo Dimming  
Gunmetal Powder Coat Finish  
Snowflake Fabric Shade w/ Self-Fabric Top Diffuser

FINISH/SHADE OPTIONS:

- 1804** Stardust White  
White Mont. Blanc Parchment
- Z1814** Dark Bronze  
Snowflake Fabric
- 1834** Matte Black  
Snowflake Fabric



1827



Z1819



1806



1839

# Real Simple

REAL SIMPLE

## 1827 4-Light Chandelier

4 - 60W Max.  
Bulb Type: B10, Candelabra  
Direct Wire Only  
Gunmetal Powder Coat Finish  
Snowflake Fabric Shades w/ Self-Fabric Bottom Diffusers  
Susp. Hardware: 3 pcs. 5/8" x 12" & 1 pc. 5/8" x 6" Extensions

FINISH/SHADE OPTIONS:

- 1807** Stardust White  
White Mont Blanc Parchment
- Z1817** Dark Bronze  
Snowflake Fabric
- 1837** Matte Black  
Snowflake Fabric

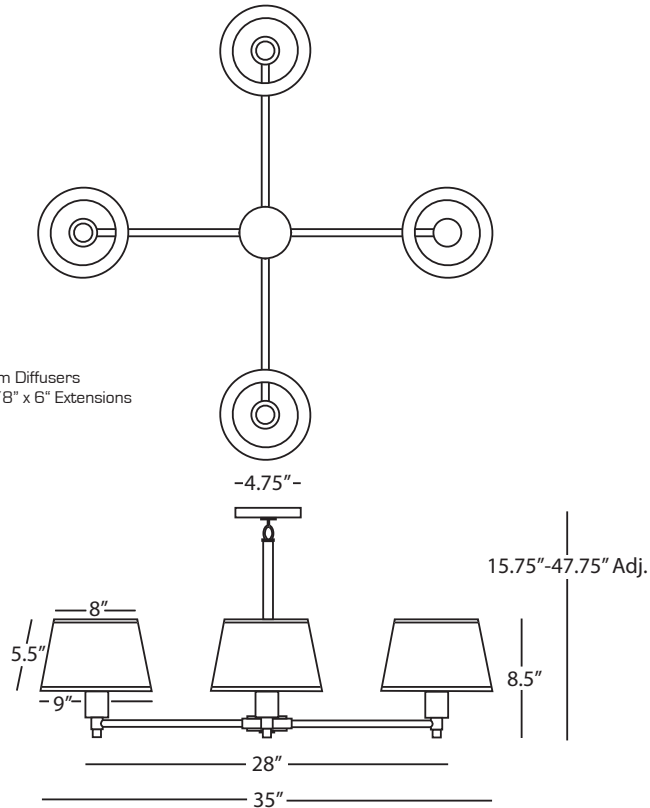

REAL SIMPLE

## 1806 Swing Arm Sconce

1 - 60W Max.  
Bulb Type: A  
Switch: Hi-Lo Dimming  
24" Cord Cover/Direct Wire  
Stardust White Powder Coat Finish  
White Mont Blanc Parchment Shade  
w/ Self-Fabric Bottom Diffuser

FINISH/SHADE OPTIONS:

- Z1816** Dark Bronze  
Snowflake Fabric
- 1826** Gunmetal  
Snowflake Fabric
- 1836** Matte Black  
Snowflake Fabric

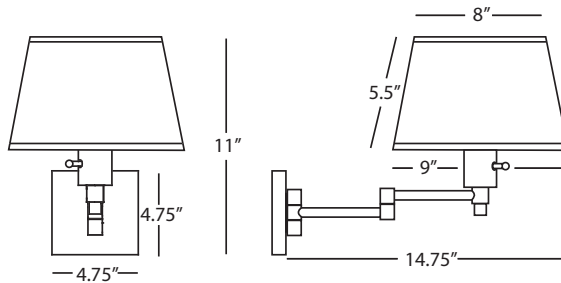

REAL SIMPLE

## Z1819 Wall Mounted Boom Lamp

1 - 60W Max.  
Bulb Type: A  
Switch: Hi-Lo Dimming  
24" Cord Cover/Direct Wire  
Dark Bronze Powder Coat Finish  
Snowflake Fabric Shade w/ Self-Fabric Bottom Diffuser

FINISH/SHADE OPTIONS:

- 1809** Stardust White  
White Mont Blanc Parchment
- 1829** Gunmetal  
Snowflake Fabric
- 1839** Matte Black  
Snowflake Fabric

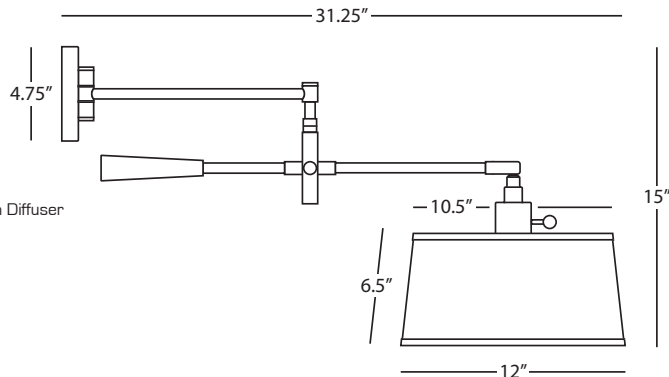



B1316



Z1316



C1317



S1314



Z1314



# Roderick

RODERICK

## **B1316** 10" Dia. Flush Mount

1 - 60W Max.  
Bulb Type: B10, Candelabra  
Direct Wire Only  
Antique Silver Finish  
White Frosted Glass Shade

FINISH OPTIONS:

**C1316** Polished Chrome  
**S1316** Polished Nickel  
**Z1316** Deep Patina Bronze

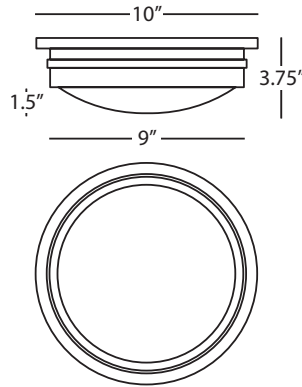

RODERICK

## **Z1314** 13.5" Dia. Flush Mount

2 - 60W Max.  
Bulb Type: B11 Torpedo  
Direct Wire Only  
Deep Patina Bronze  
White Frosted Glass Shade

FINISH OPTIONS:

**B1314** Antique Silver  
**C1314** Polished Chrome  
**S1314** Polished Nickel

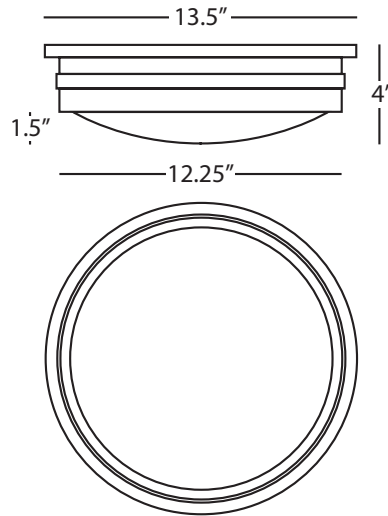

RODERICK

## **C1317** 17" Dia. Flush Mount

3 - 60W Max.  
Bulb Type: B11 Torpedo  
Direct Wire Only  
Polished Chrome  
White Frosted Glass Shade

FINISH OPTIONS:

**B1317** Antique Silver  
**S1317** Polished Nickel  
**Z1317** Deep Patina Bronze

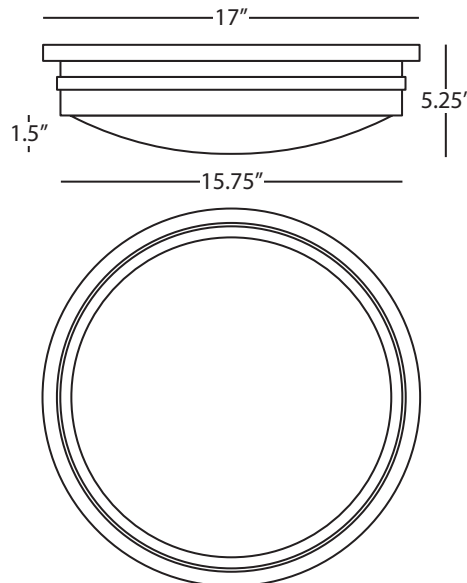



B1350

C1350

S1350

W1350

Z1350

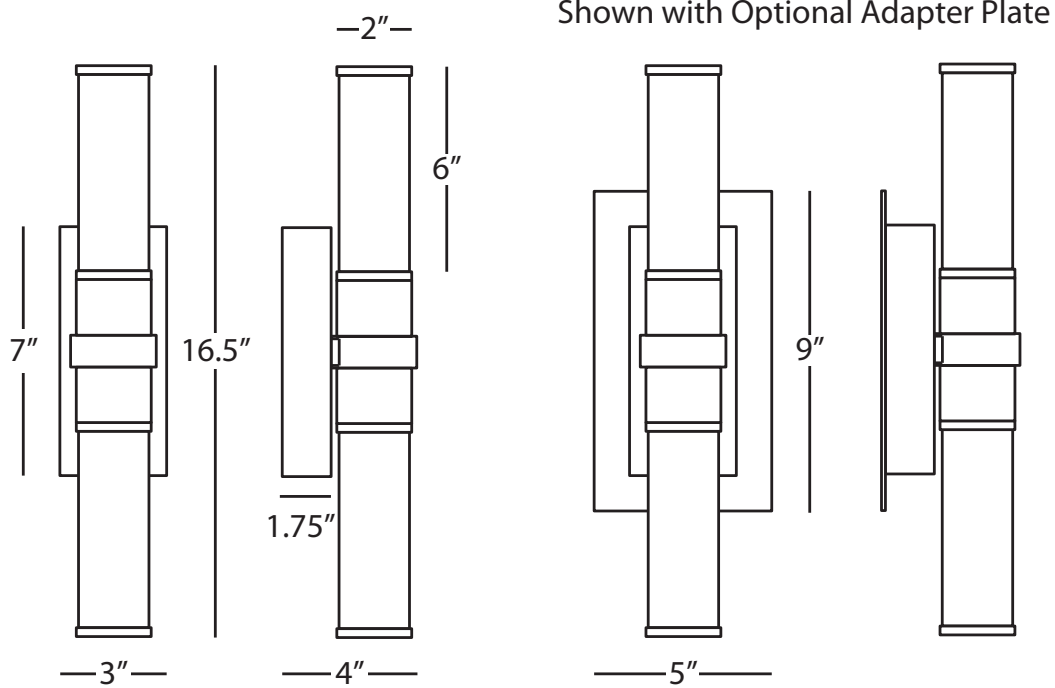

RODERICK

## B1350

### Bath Sconce

2 - 10W Max.  
 Bulb Type: Solid State LED (Non-Replaceable)  
 LED Color Temp: 3000K, CRI: 90+  
 Lumen Output: 1600  
 Direct Wire Only, Fully Dimmable  
 Antique Silver Finish  
 White Frosted Glass Shades  
 UL Rated for Damp Locations  
 ADA Compliant

#### FINISH OPTIONS:

**C1350** Polished Chrome  
**S1350** Polished Nickel  
**W1350** Warm Brass  
**Z1350** Deep Patina Bronze

\*Metal Junction Box Cover Plate in Matching Finish Included



S1532



1530



1448

# Rubix

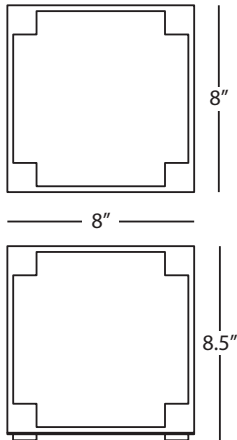

RUBIX

## 1530

### Cube Accent Lamp

1 - 15W Max.  
 (1200 Lumen Output)  
 Bulb Type: LED unit, Included (Non-Replaceable)  
 LED Color Temp: 3000, CRI: 90  
 Switch: Full Range Dimmer Line Switch  
 Modern Brass Finish  
 Faux Alabaster Shade Panels

FINISH OPTION:  
**S1530** Polished Nickel

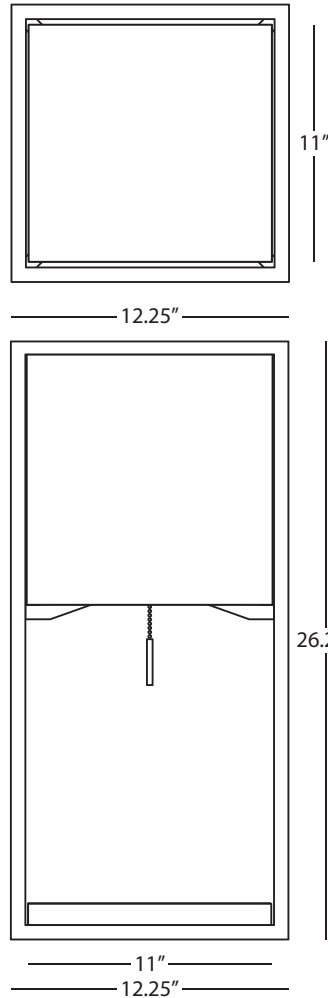

RUBIX

## 1448

### Table Lamp

1 - 100W Max.  
 Bulb Type: A  
 Switch: On-Off Pull Chain  
 Modern Brass Finish  
 Faux Alabaster Shade and Base

FINISH OPTION:  
**S1448** Polished Nickel

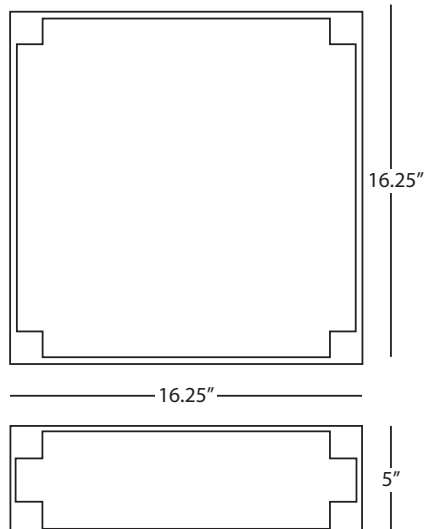

RUBIX

## S1532

### Flush Mount

1 - 26W Max.  
 (2000 Lumen Output)  
 Bulb Type: LED unit, Included (Non-Replaceable)  
 LED Color Temp: 3000, CRI: 90  
 Direct Wire  
 Polished Nickel Finish  
 Faux Alabaster Shade Panels

FINISH OPTION:  
**1532** Modern Brass



S2190



Z2181



S2195



Z2184

# Saturnia

SATURNIA

## Z2184

### Accent Lamp

1 - 60W Max.  
 Bulb Type: G16.5, Candelabra  
 Switch: On-Off Line Switch  
 Deep Patina Bronze Finish  
 Bronze Transparent Fabric Exterior Shade w/  
 Ascot White Fabric Interior Shade

FINISH/SHADE OPTION:

**S2194** Stainless Steel Finish  
 Silver Transparent Fabric  
 Exterior Shade w/ Ascot White  
 Fabric Interior Shade

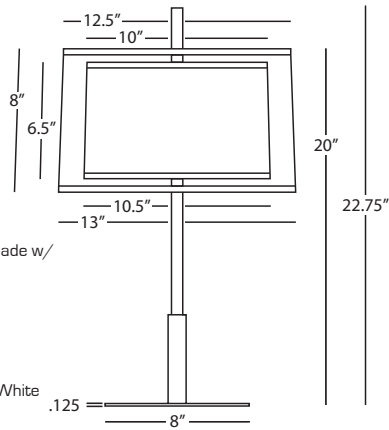

SATURNIA

## S2195

### Buffet Table Lamp

1 - 60W Max.  
 Bulb Type: G16.5, Candelabra  
 Switch: On-Off Line Switch  
 Stainless Steel Finish  
 Silver Transparent Fabric Exterior Shade w/  
 Ascot White Fabric Interior Shade

FINISH/SHADE OPTION:

**Z2185** Deep Patina Bronze Finish  
 Bronze Transparent Fabric  
 Exterior Shade w/ Ascot White  
 Fabric Interior Shade

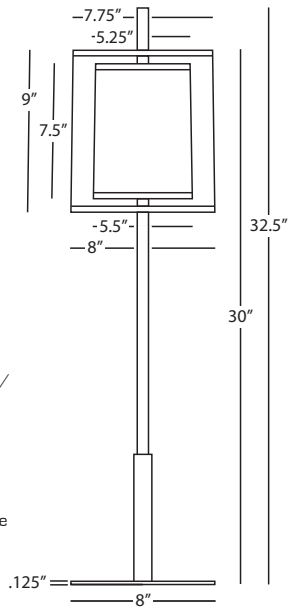

SATURNIA

## S2190

### Table Lamp

1 - 150W Max.  
 Bulb Type: A  
 Switch: 3-Way  
 Stainless Steel Finish  
 Silver Transparent Fabric Exterior Shade w/  
 Ascot White Fabric Interior Shade

FINISH/SHADE OPTION:

**Z2180** Deep Patina Bronze Finish  
 Bronze Transparent Fabric  
 Exterior Shade w/ Ascot White  
 Fabric Interior Shade

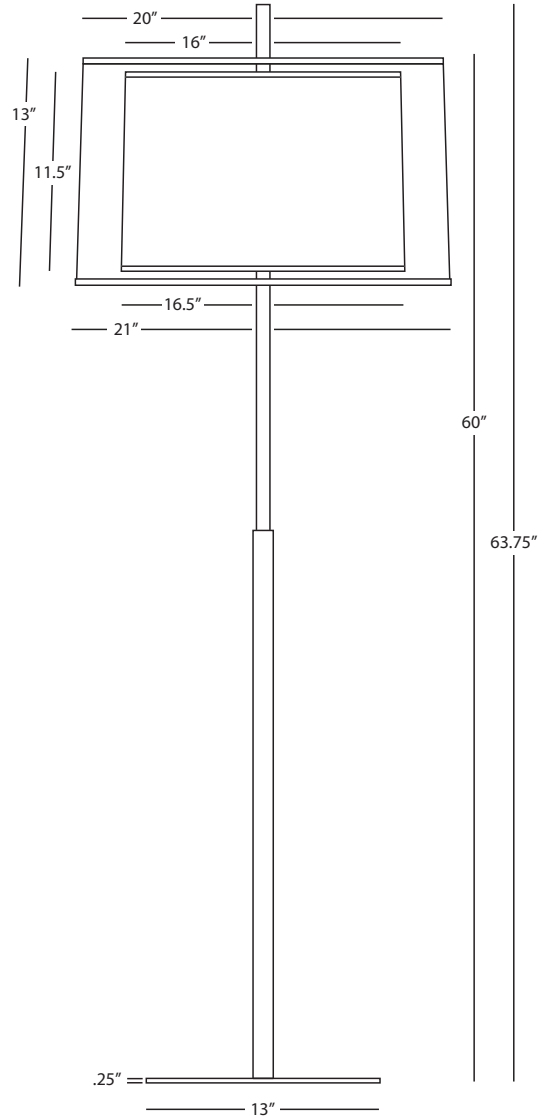
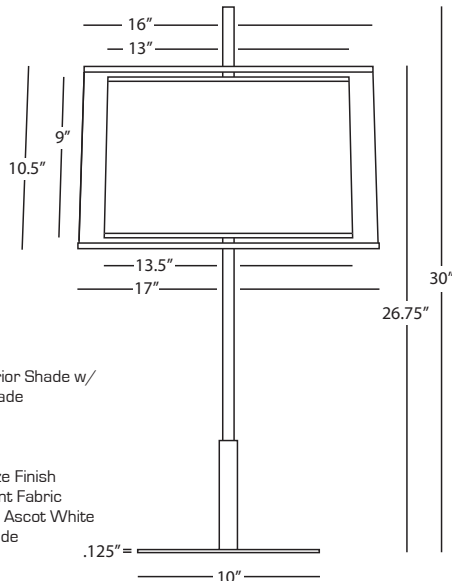

SATURNIA

## Z2181

### Floor Lamp

1 - 150W Max.  
 Bulb Type: A  
 Switch: 3-Way  
 Deep Patina Bronze Finish  
 Bronze Transparent Fabric Exterior Shade w/  
 Ascot White Fabric Interior Shade

FINISH/SHADE OPTION:

**S2191** Stainless Steel Finish  
 Silver Transparent Fabric  
 Exterior Shade w/ Ascot White  
 Fabric Interior Shade



S2192



Z2187



S2193



S2196



Z2188



# Saturnia

SATURNIA

## Z2188 6-Light Chandelier

6 - 60W Max.  
Bulb Type: G16.5 Candelabra  
Direct Wire Only  
Deep Patina Bronze Finish  
Bronze Transparent Fabric Exterior Shades w/  
Ascot White Fabric Interior Shades  
Susp. Hardware: 3 pcs. 5/8" x 12" &  
1 pc. 5/8" x 6" Extensions

FINISH/SHADE OPTION:

**S2198** Stainless Steel Finish  
Silver Transparent Fabric  
Exterior Shades w/  
Ascot White Fabric Interior Shades

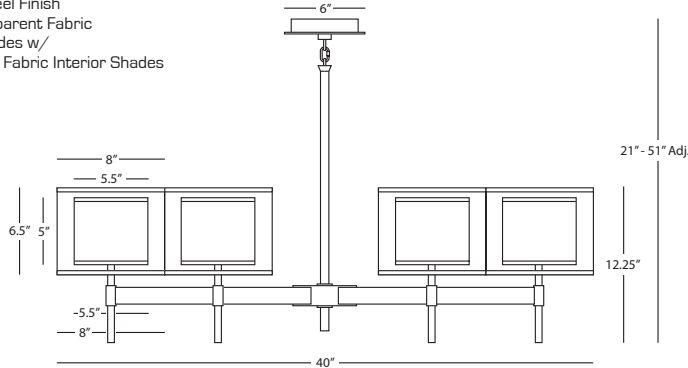
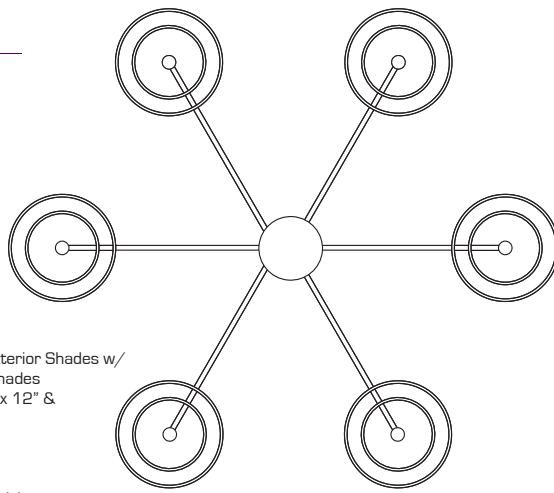

SATURNIA

## Z2187 Semi-Flush Mount

2 - 100W Max.  
Bulb Type: A  
Direct Wire Only  
Deep Patina Bronze Finish  
Bronze Transparent Fabric Exterior Shade  
w/ Ascot White Fabric Interior Shade  
13.5" Dia. White Acrylic Diffuser

FINISH/SHADE OPTION:

**S2197** Stainless Steel Finish  
Silver Transparent Fabric  
Exterior Shade w/ Ascot White  
Fabric Interior Shade

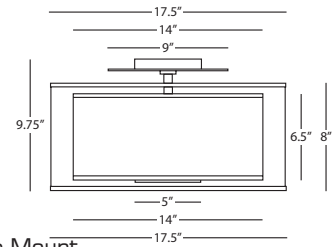

SATURNIA

## S2193 Pendant

3 - 100W Max.  
Bulb Type: A  
Direct Wire Only  
Stainless Steel Finish  
Silver Transparent Fabric Exterior Shade w/  
Ascot White Fabric Interior Shade  
19" Dia. White Acrylic Diffuser  
Susp. Hardware: 3 pcs. 5/8" x 12" &  
1 pc. 5/8" x 6" Extensions

FINISH/SHADE OPTION:

**Z2183** Deep Patina Bronze Finish  
Bronze Transparent Fabric  
Exterior Shade w/ Ascot White  
Fabric Interior Shade

SATURNIA

## S2196 Narrow Pendant

1 - 60W Max.  
Bulb Type: B, Candelabra  
Direct Wire Only  
Stainless Steel Finish  
Silver Transparent Fabric Exterior Shade  
w/ Ascot White Fabric Interior Shade  
Susp. Hardware: 3 pcs. 5/8" x 12" &  
1 pc. 5/8" x 6" Extensions

FINISH/SHADE OPTION:

**Z2186** Deep Patina Bronze Finish  
Bronze Transparent Fabric  
Exterior Shade w/ Ascot White  
Fabric Interior Shade

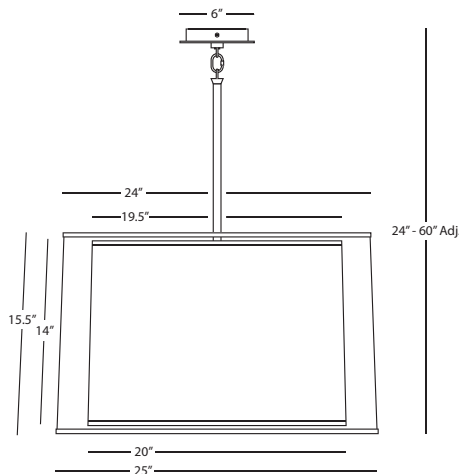
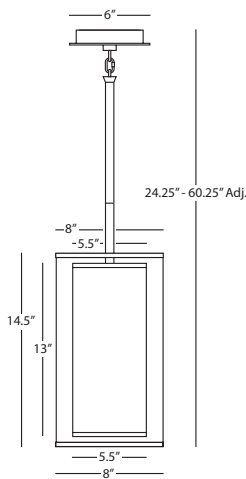

SATURNIA

## S2192 Wall Sconce

1 - 60W Max.  
Bulb Type: B, Candelabra  
Switch: On-Off Line Switch  
24" Cord Cover/Direct Wire  
Stainless Steel Finish  
Silver Transparent Fabric Exterior Shade  
w/ Ascot White Fabric Interior Shade

FINISH/SHADE OPTION:

**Z2182** Deep Patina Bronze Finish  
Bronze Transparent Fabric  
Exterior Shade w/ Ascot  
White Fabric Interior Shade

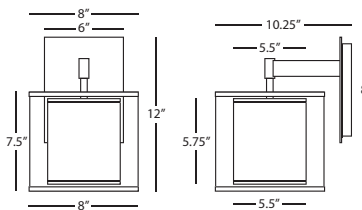



Z2155

# Saturnia

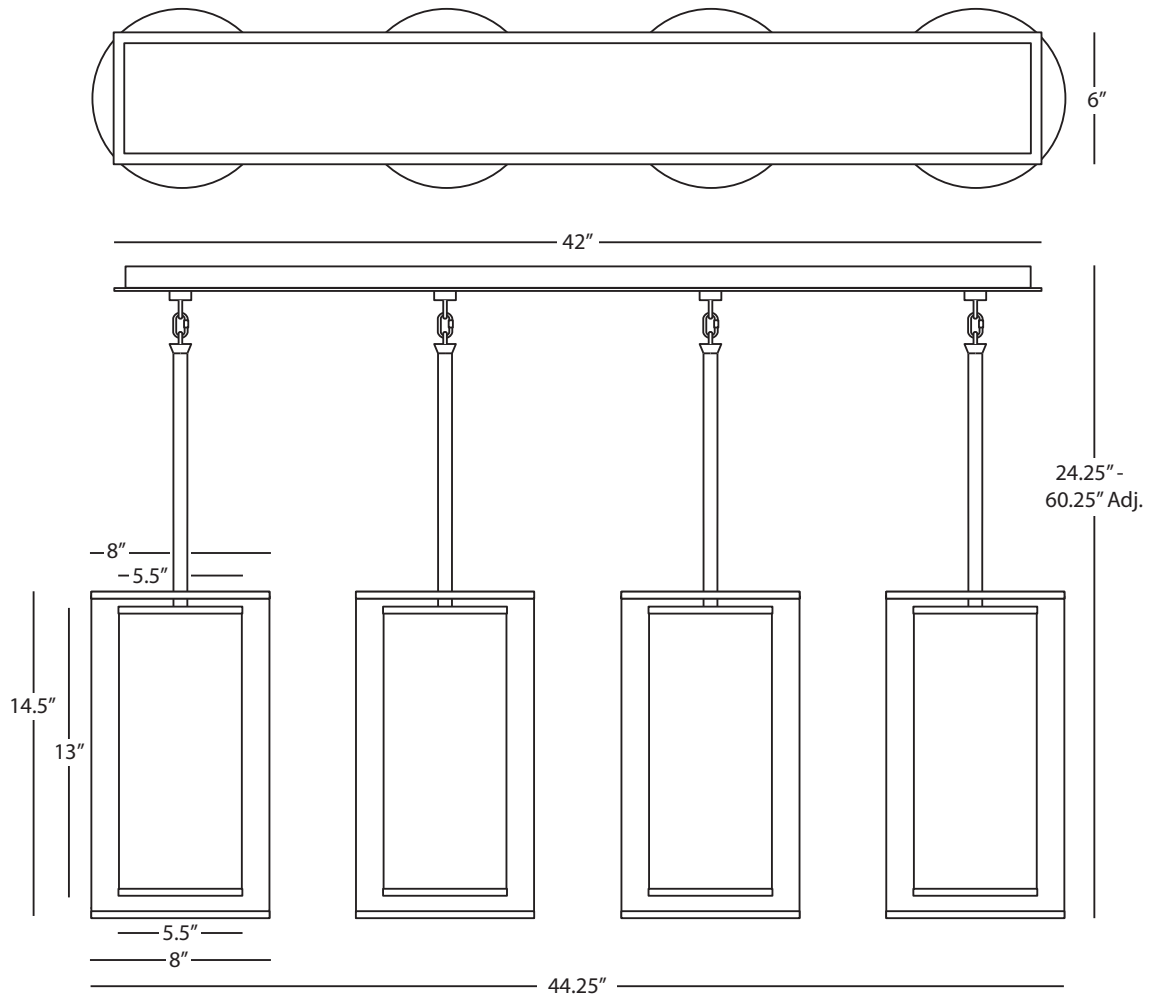

SATURNIA

## Z2155

### Linear Chandelier

4 - 60W Max.  
Bulb Type: B, Candelabra  
Direct Wire  
Deep Patina Bronze Finish  
Bronze Transparent Fabric  
Exterior Shades w/ Ascot  
White Fabric Interior Shades  
Susp. Hardware: 12 pcs. 5/8" x 12" &  
4 pcs. 5/8" x 6" Extensions



S1551



1597



S1597

SIMON

## 1597

### Swing Arm Sconce

1 - 60W Max.  
 Bulb Type: A  
 Switch: Hi-Lo Dimming  
 24" Cord Cover/Direct Wire  
 Satin Black Finish w/  
 Modern Brass Accents  
 Adjustable Metal Shade

FINISH OPTION:

**S1597** Satin Black Finish w/  
 Polished Nickel Accents

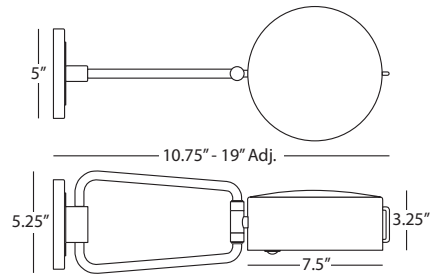

SIMON

## S1551

### Chandelier

6 - 60W Max.  
 Bulb Type: A  
 Direct Wire  
 Satin Black Finish w/  
 Polished Nickel Finished Accents  
 Adjustable Metal Shades  
 Susp. Hardware: 3 pcs. 5/8" x 12" & 1  
 pc. 5/8" x 6" Extensions

FINISH OPTION:

**1551** Satin Black Finish w/  
 Modern Brass Accents

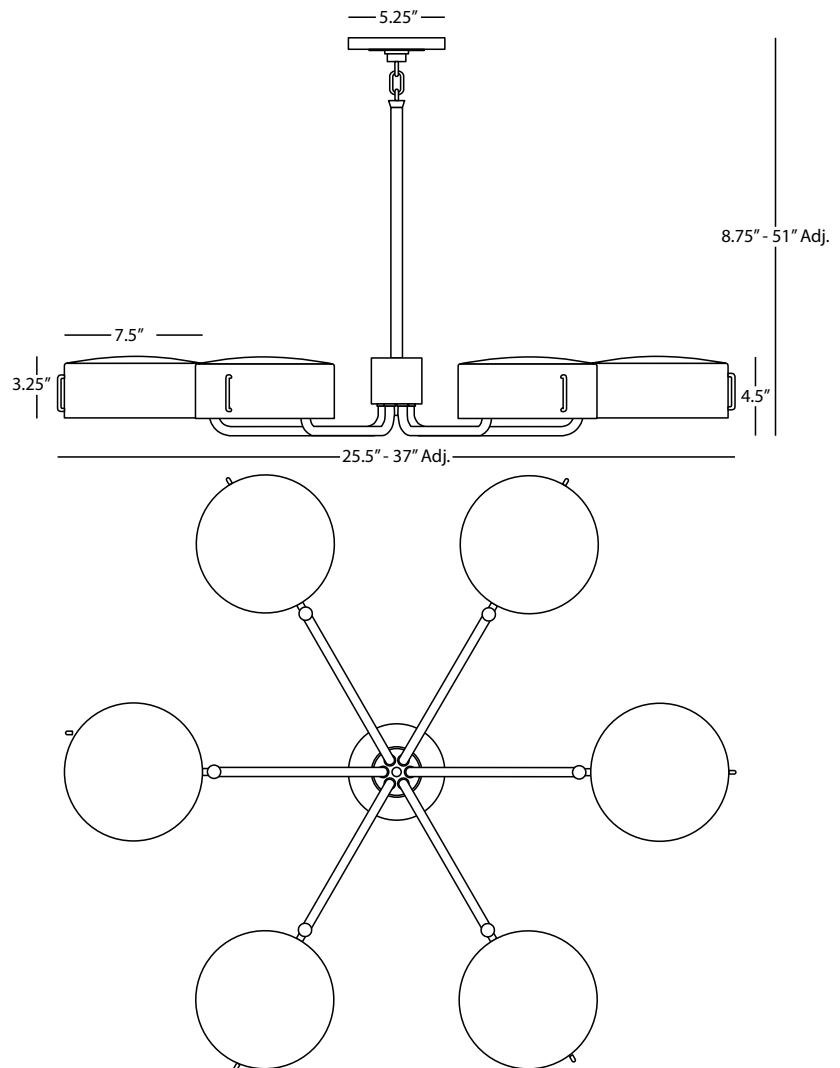



1957



1958



1957B



1958B

SLOAN

## 1957 Table Lamp

2 - 100W Max.  
Bulb Type: A  
Switch: On-Off Pull Chains  
Lead Crystal w/ Aged Brass Accents  
Rectangular Ivory Silk Box Pleat Shade  
w/ Off-White Silk Lining

SHADE OPTION:

**1957B** Black Painted Opaque Parchment  
Matte Gold Lining

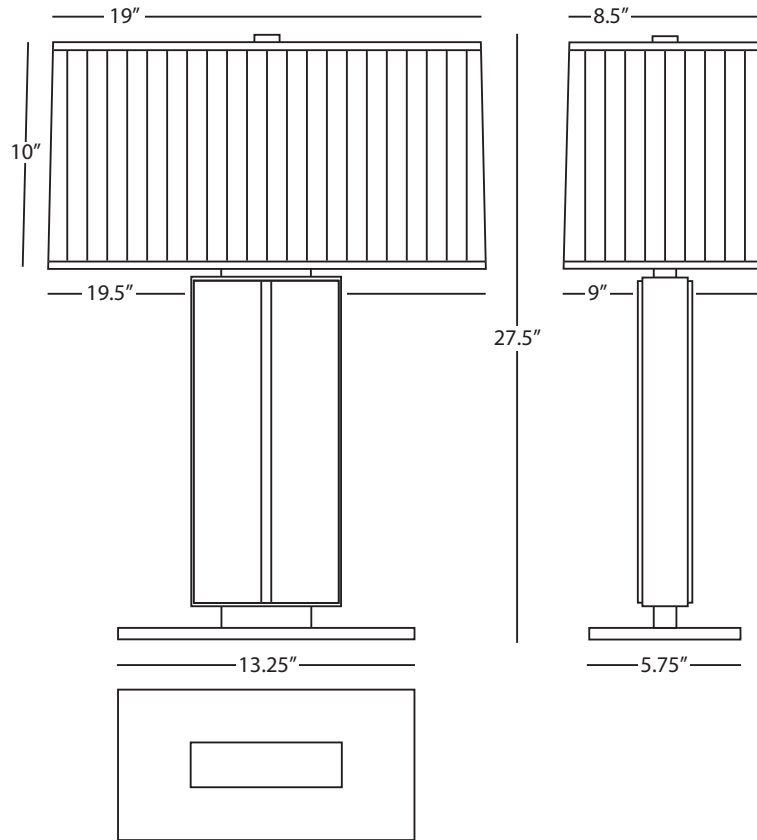

SLOAN

## 1958B Wide Table Lamp

2 - 100W Max.  
Bulb Type: A  
Switch: On-Off Pull Chains  
Lead Crystal w/ Aged Brass Accents  
Rectangular Black Painted Opaque Parchment Shade  
w/ Matte Gold Lining

SHADE OPTION:

**1958** Ivory Silk Box Pleat Shade  
Off-White Silk Lining

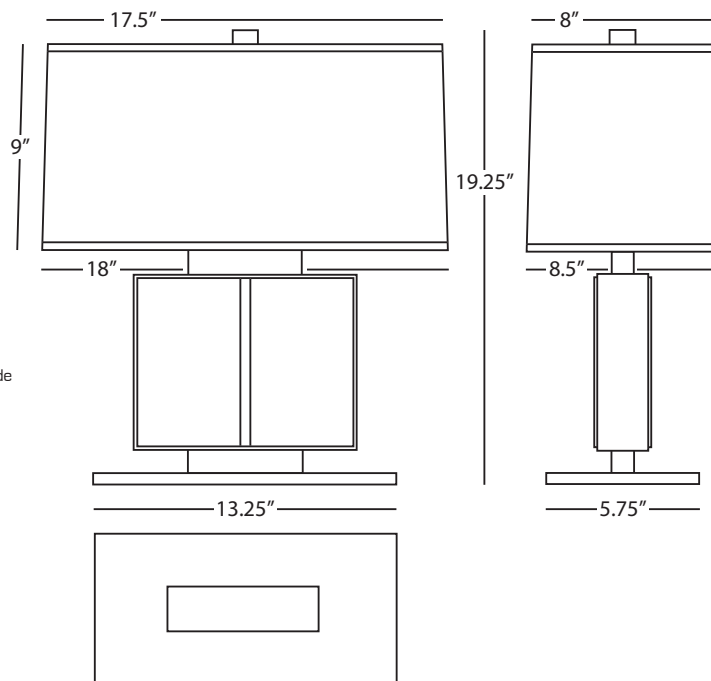



2824



D2824



Z2824



# Sofia

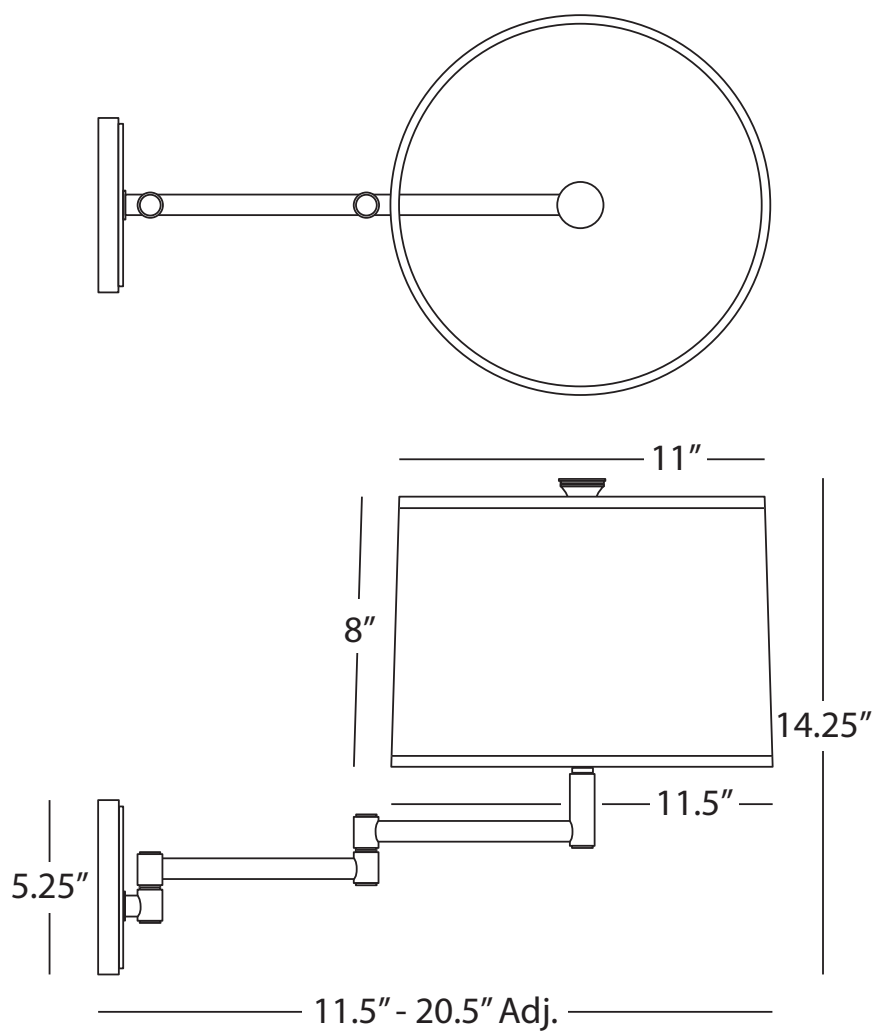

SOFIA

## 2824

### Swing Arm Wall Sconce

1 - 100W Max.  
Bulb Type: A  
Switch: Hi-Lo Dimming  
24" Cord Cover/Direct Wire  
Antique Brass Finish  
Open Weave White Linen Shade

#### FINISH/SHADE OPTIONS:

**D2824** Dark Antique Nickel  
Open Weave White Linen  
**Z2824** Deep Patina Bronze  
Open Weave Heather Linen



S1917



1916

# Spectrum

SPECTRUM

## S1917 Small Pendant

2 - 60W Max.  
Bulb Type: G16.5, Candelabra  
Direct Wire  
Polished Nickel Finish  
Clear Crystal Prisms  
Susp. Hardware: 3 Ft. Chain

FINISH OPTION:  
**1917** Modern Brass

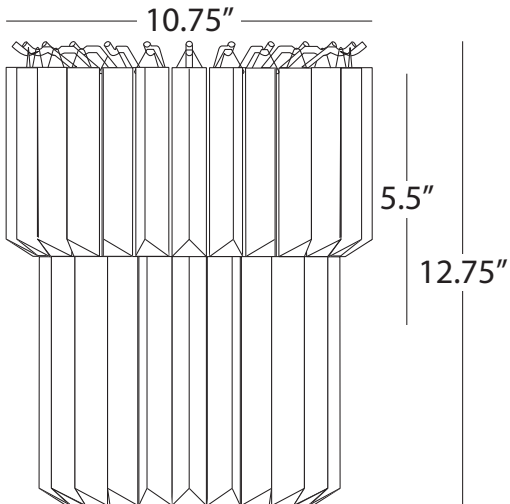
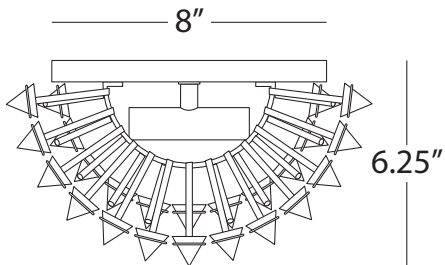
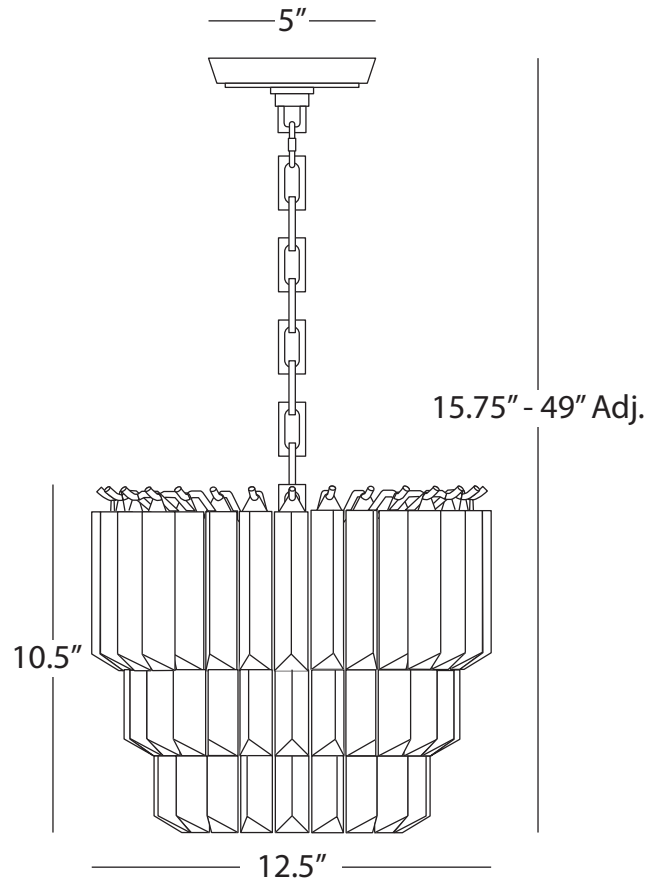

SPECTRUM

## 1916 Half Round Wall Sconce

2 - 40W Max.  
Bulb Type: G16.5, Candelabra  
On-Off Line Switch  
24" Cord Cover/Direct Wire  
Modern Brass Finish  
Clear Crystal Prisms

FINISH OPTION:  
**S1916** Polished Nickel



125

# Tic-Tac-Toe

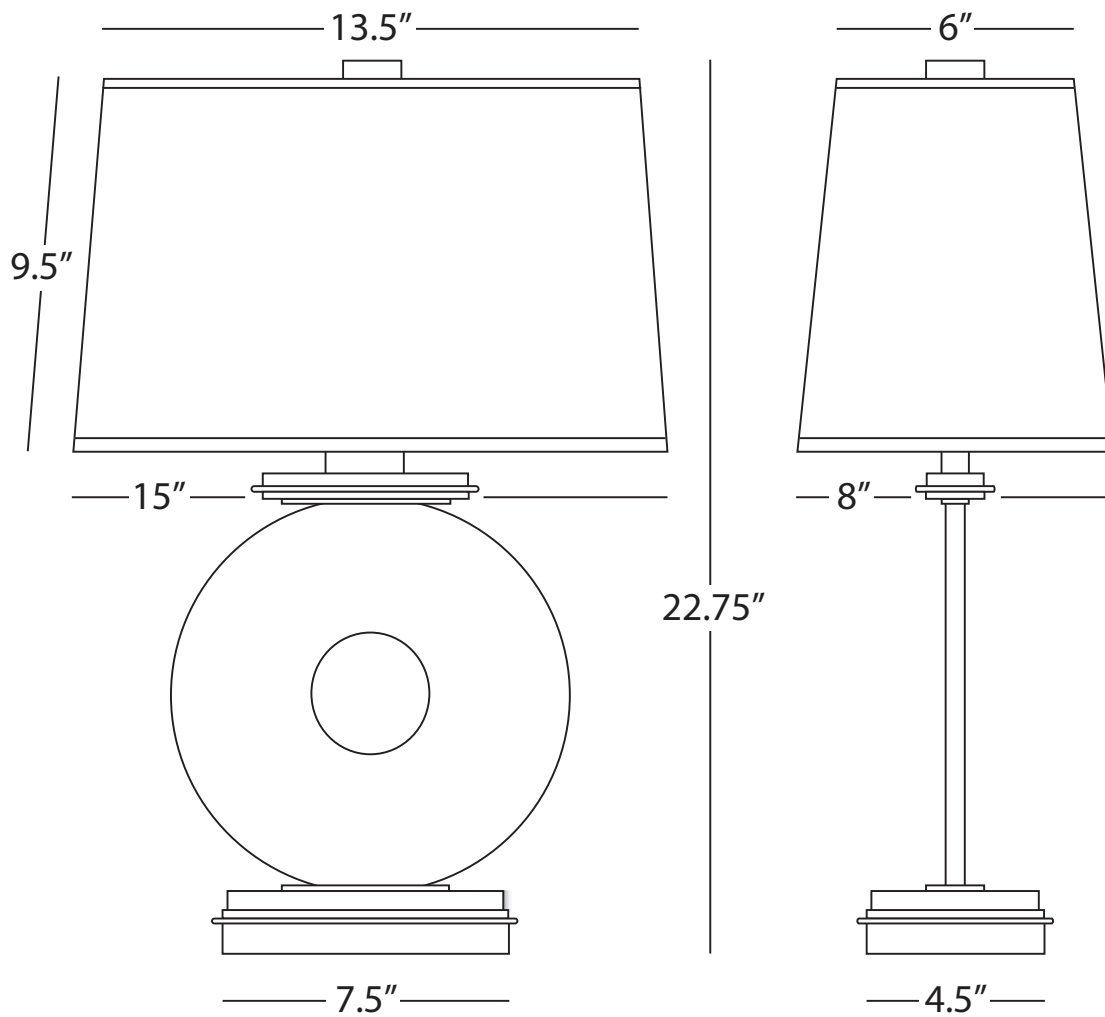

TIC-TAC-TOE

## 125

### Table Lamp

1 - 150W Max.

Bulb Type: A

Switch: 3-Way

Antique Brass Finish w/ Black Marble Accents

Rectangular Pale Shell Dupioni Fabric Shade



2088

# Treble

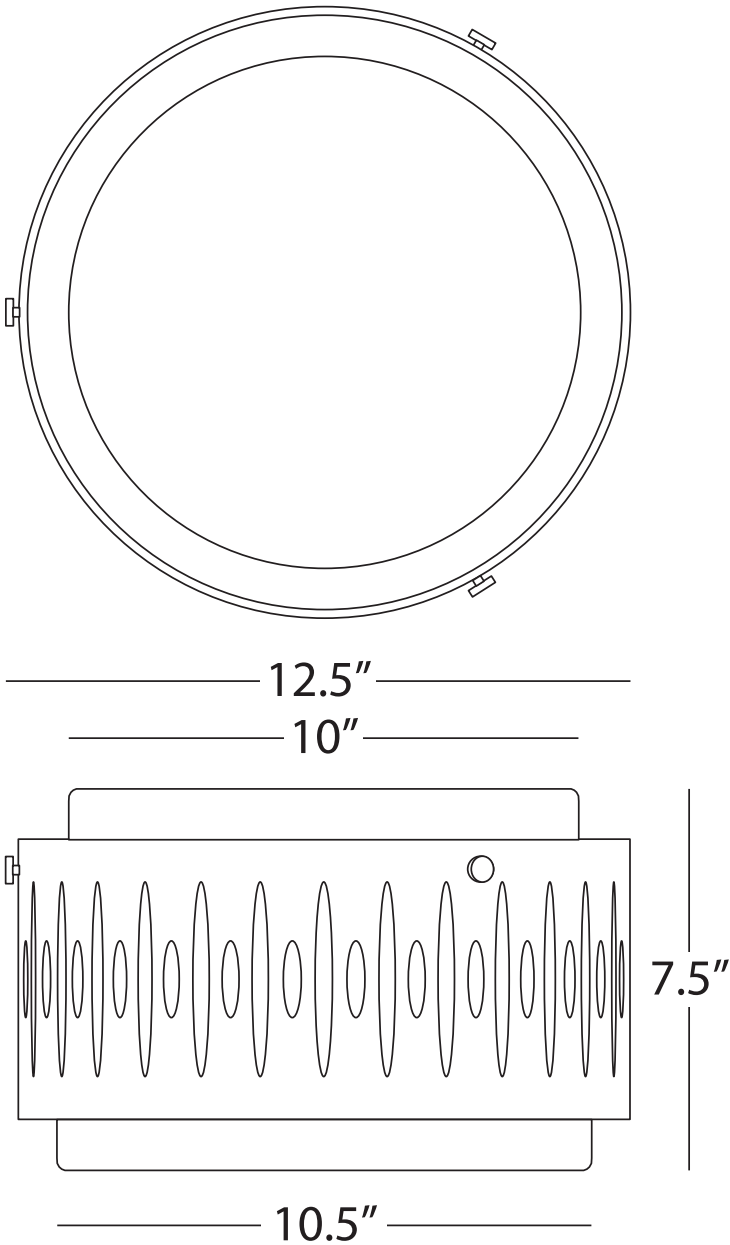

TREBLE

**2088**  
Small Flush Mount

3 - 60W Max.  
Bulb Type: B, Medium Base  
Direct Wire  
Modern Brass Finish  
White, Frosted Glass Shade

# Triple Gourd



378X



A282X



EG31X



A368X



RR42X



# Triple Gourd

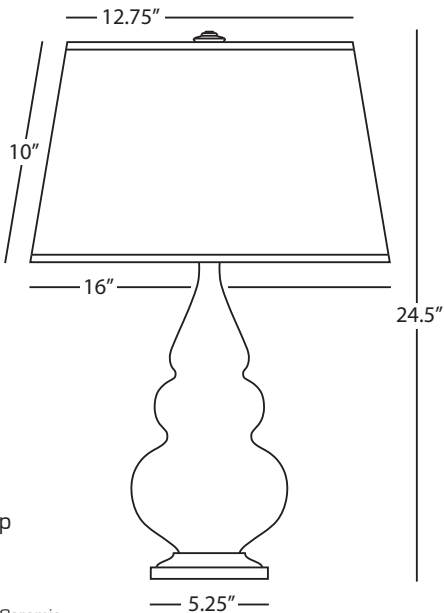

TRIPLE GOURD

## 378X Accent Lamp

1 - 150W Max.  
Bulb Type: A  
Switch: 3-Way  
Amethyst Glazed Ceramic  
Antique Brass Finished Accents  
Pearl Dupioni Fabric Shade

See Page 237 for Color/Base/Shade Options

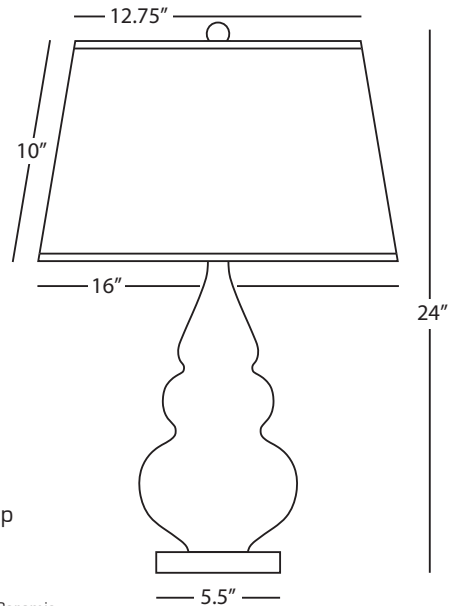

TRIPLE GOURD

## A282X Accent Lamp

1 - 150W Max.  
Bulb Type: A  
Switch: 3-Way  
Pumpkin Glazed Ceramic  
Square Lucite Base  
Pearl Dupioni Fabric Shade

See Page 237 for Color/Base/Shade Options

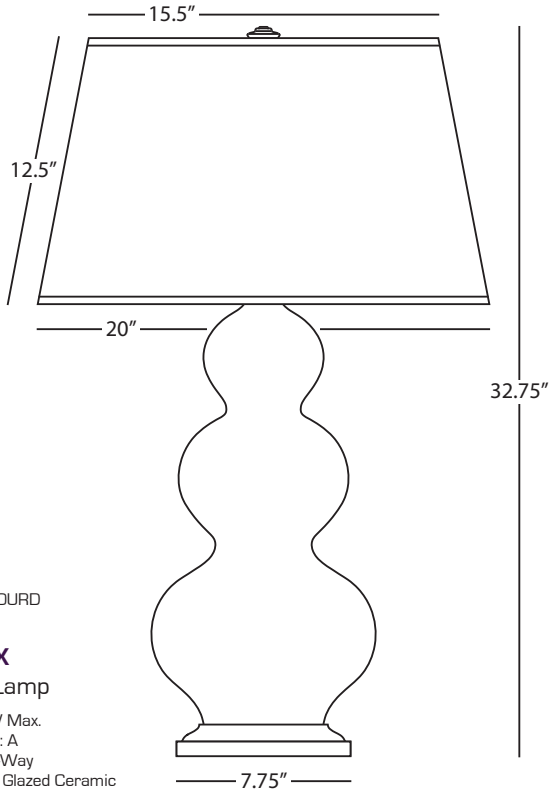

TRIPLE GOURD

## RR42X Table Lamp

1 - 150W Max.  
Bulb Type: A  
Switch: 3-Way  
Ruby Red Glazed Ceramic  
Antique Silver Finished Accents  
Pearl Dupioni Fabric Shade

See Page 237 for Color/Base/Shade Options

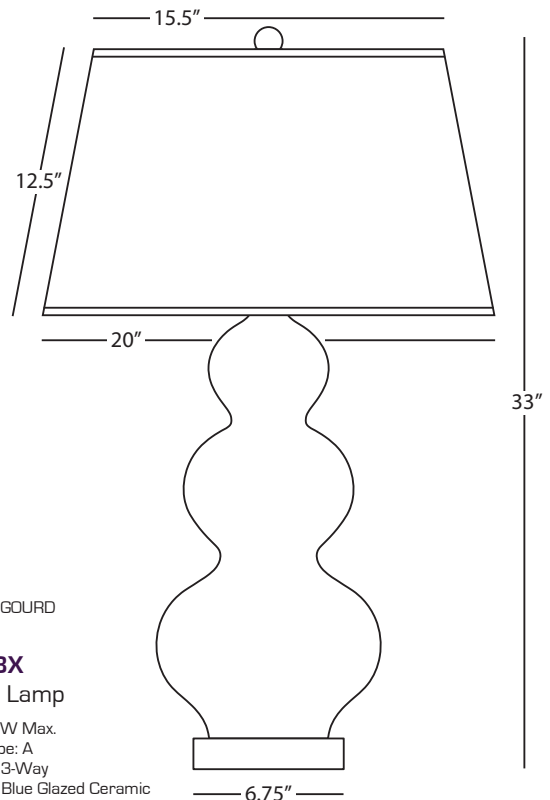

TRIPLE GOURD

## A368X Table Lamp

1 - 150W Max.  
Bulb Type: A  
Switch: 3-Way  
Marine Blue Glazed Ceramic  
Square Lucite Base  
Pearl Dupioni Fabric Shade

See Page 237 for Color/Base/Shade Options



B1310



C1310



S1310



Z1310

# Tyrone

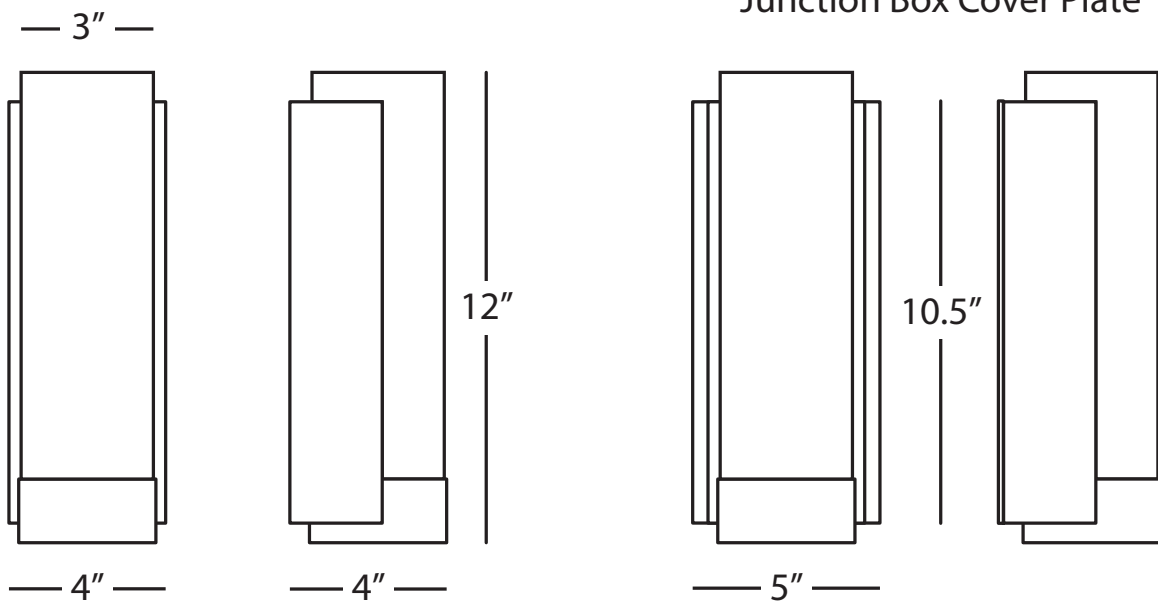

TYRONE

## B1310

Wall Sconce

1 - 60W Max.  
Bulb Type: A  
Direct Wire Only  
Antique Silver Finish  
White Frosted Glass Shade  
UL Rated for Damp Locations  
ADA Compliant

### FINISH OPTIONS:

**C1310** Polished Chrome  
**S1310** Polished Nickel  
**Z1310** Deep Patina Bronze

\*Metal Junction Box Cover Plate in Matching Finish Included

| Victor



# Victor

[Click photo above to watch Victor Table Lamp video](#)

The Victor collection features a simple silhouette with a gentle taper that blends well with a range of styles. Available in a wide array of colors, this table lamp can create gorgeous contrast for your space or add just the right amount of a certain hue.



MB03



AP03



LY03



CR03



EB03



EG03

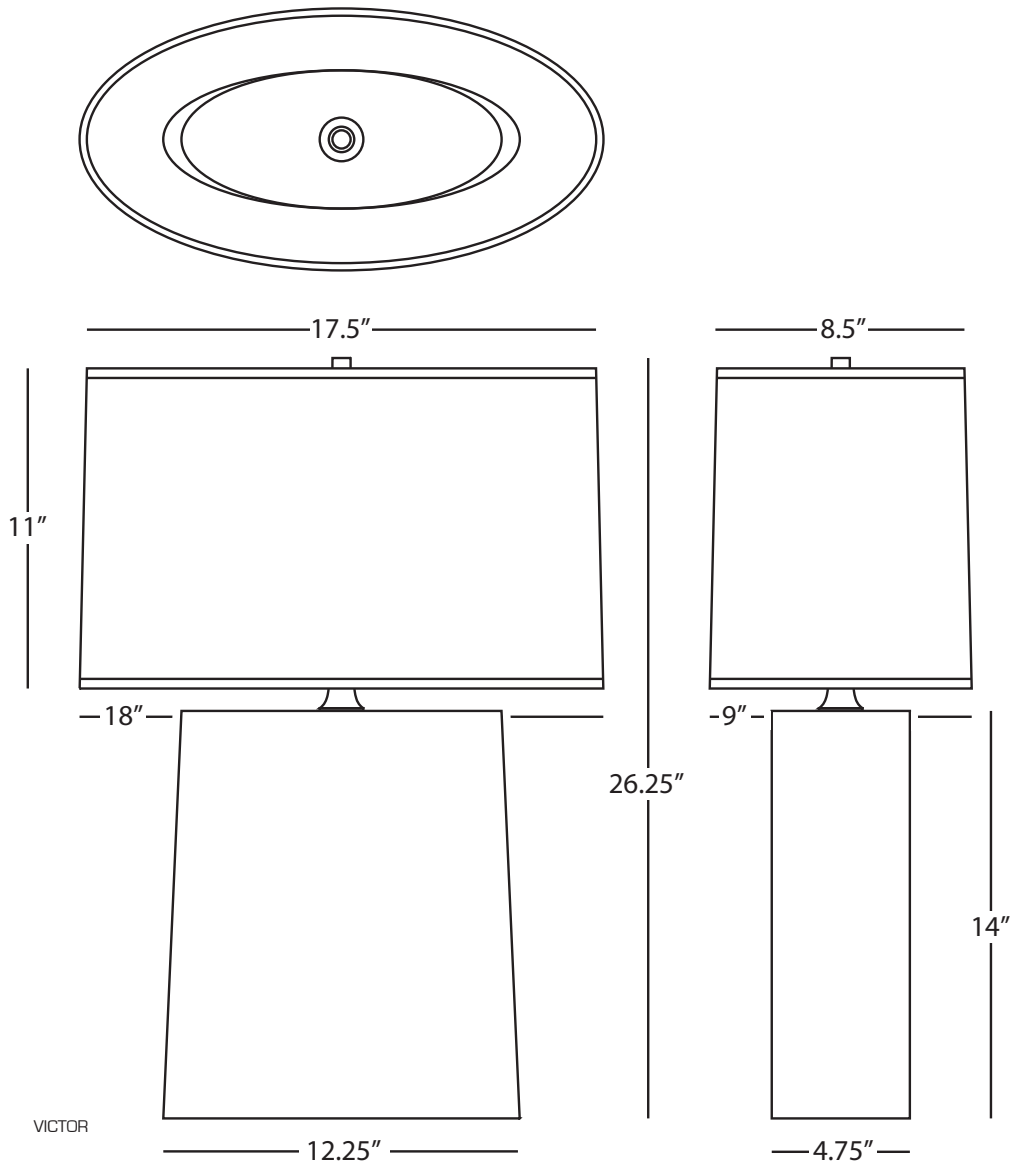

## MB03

### Table Lamp

1 - 100W Max.  
Bulb Type: A  
Switch: Full Range Dimmer  
Midnight Blue Glazed Ceramic  
Midnight Blue Accents  
Oval Ascot White Shade

See Page 238 for Color Options



434



435



# Wavy

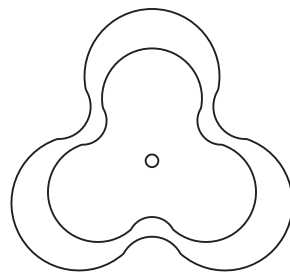
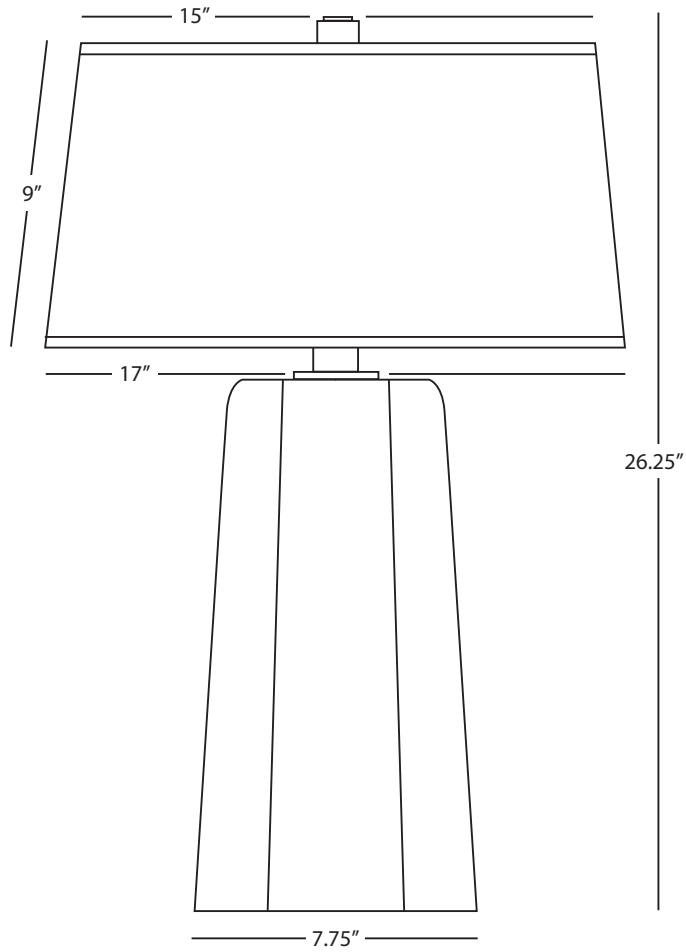

WAVY

## 434 Table Lamp

1 - 100W Max.  
Bulb Type: A  
Switch: Full Range Dimmer  
White Cased Glass w/ Polished Nickel Accents  
Translucent White Mont Blanc Parchment Shade

FINISHOPTION:

435 Silver Mercury Glass



2607X



2609X



2606X

# Wilton

WILTON

## 2609X Table lamp

1 - 150W Max.  
Bulb Type: A  
Switch: 3-Way  
Antique Rust Finish  
Golden Saki Fabric Shade

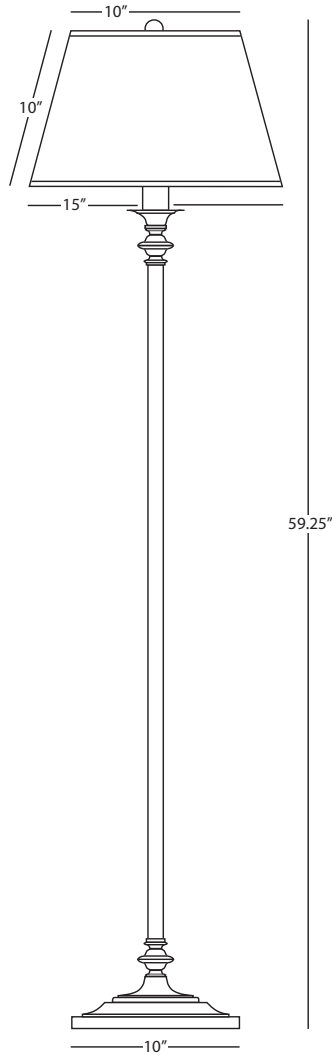
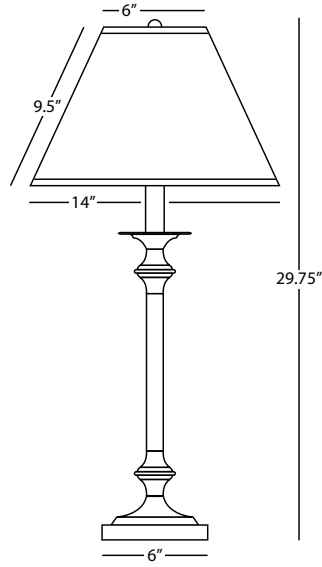

WILTON

## 2606X Club Floor Lamp

1 - 150W Max.  
Bulb Type: A  
Switch: 3-Way  
Antique Rust Finish  
Golden Saki Fabric Shade

WILTON

## 2607X Swing Arm Floor Lamp

1 - 150W Max.  
Bulb Type: A  
Switch: 3-Way  
Antique Rust Finish  
Golden Saki Fabric Shade

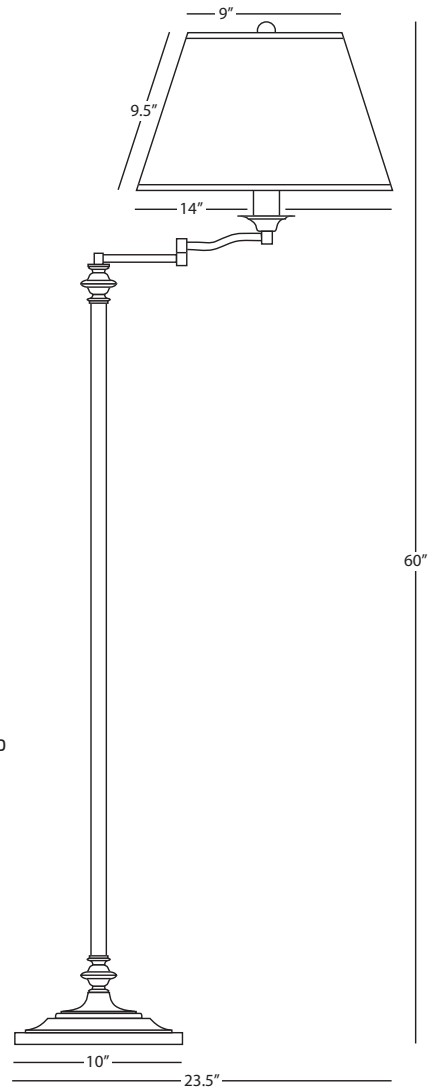



S4237



4237

# Wonton

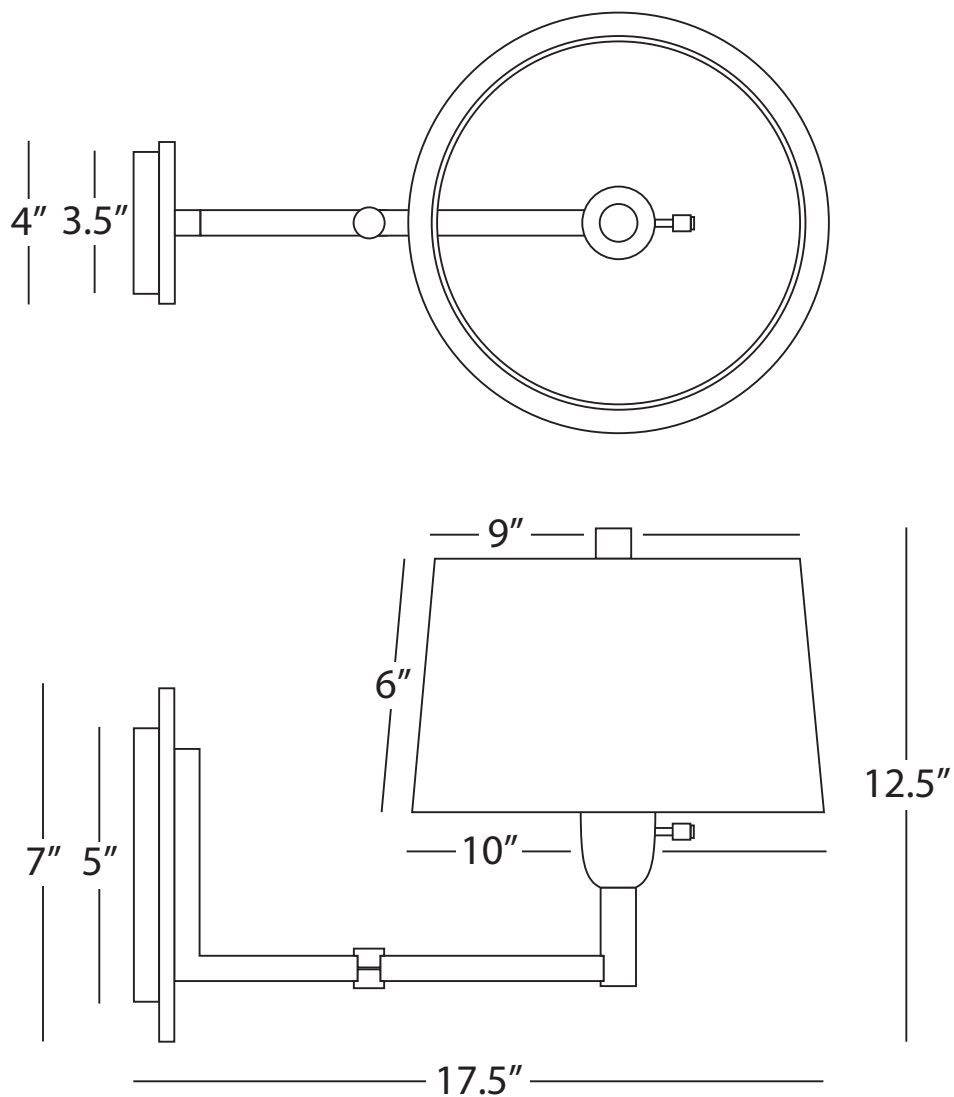

WONTON

## S4237

### Swing Arm Sconce

1 - 100W Max.  
Bulb Type: A  
Switch: Full Range Dimmer  
24" Cord Cover/Direct Wire  
Silver Plate Finish w/  
Weathered Ebony Finished Wood Accents  
Off-White Linen Shade w/ Rolled Edge Hem

#### FINISH/SHADE OPTION:

**4237** Deep Patina Bronze w/ Cherry Finished Wood  
Light Beige Linen Shade w/ Rolled Edge Hem



299B



297

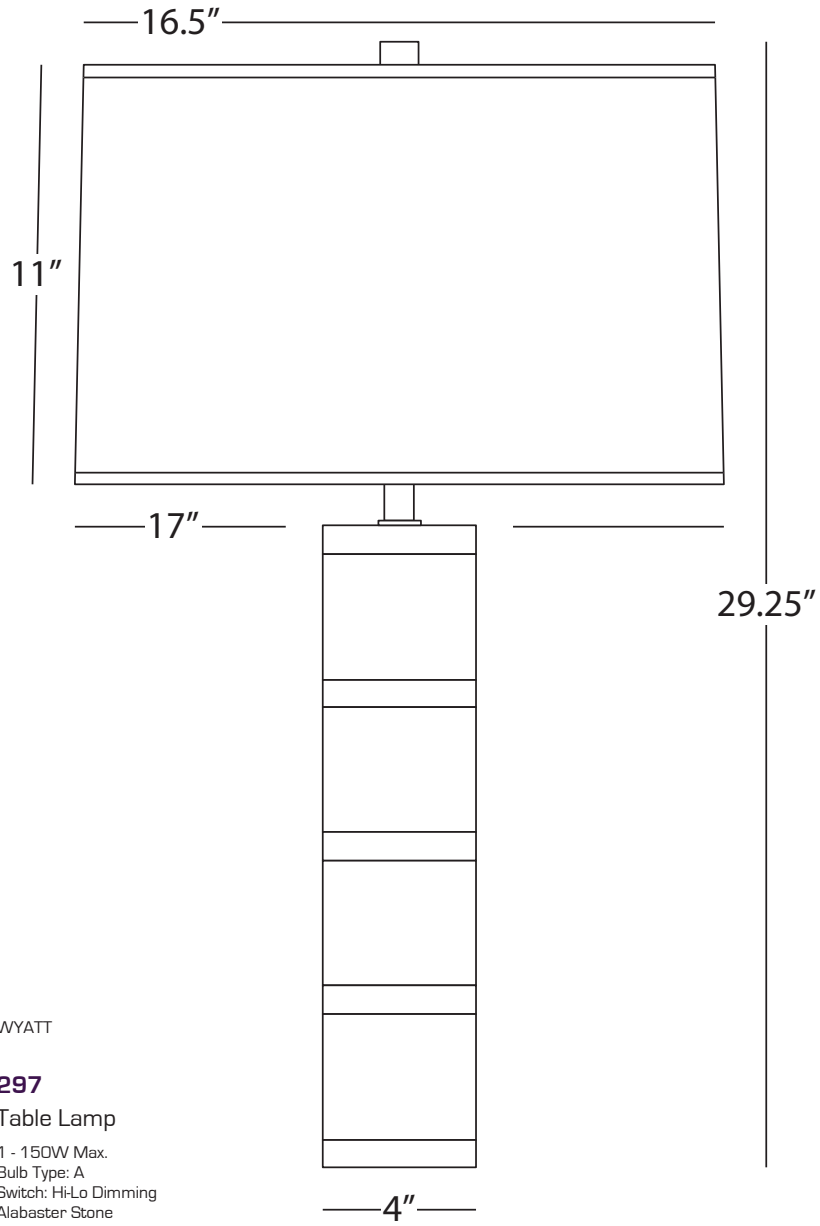

WYATT

**297**  
Table Lamp

1 - 150W Max.  
Bulb Type: A  
Switch: Hi-Lo Dimming  
Alabaster Stone  
Modern Brass Finish  
Fondine Fabric Shade

- FINISH/SHADE OPTIONS:
- 297B** Alabaster Stone/Modern Brass  
Black Opaque Parchment w/  
White Lining
  - 299** Clear Crystal/Modern Brass  
Fondine Fabric
  - 299B** Clear Crystal/Modern Brass  
Black Opaque Parchment w/  
White Lining



S251



250



Z251



WYATT

**250**

24" Picture Light

2 - 25W Max.  
 Bulb Type: B, Medium Base  
 Switch: On-Off Line Switch  
 24" Cord Cover/Direct Wire  
 Modern Brass Finish  
 Metal Shade

FINISH OPTIONS:

- S250** Polished Nickel
- Z250** Deep Patina Bronze

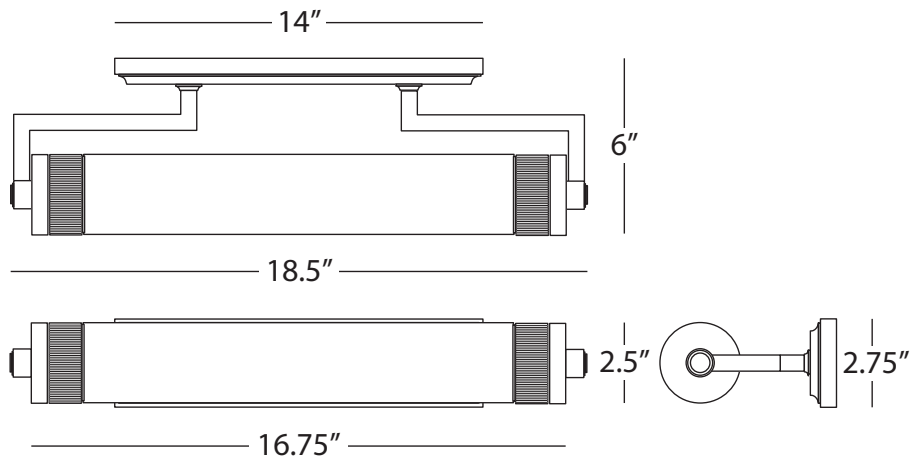
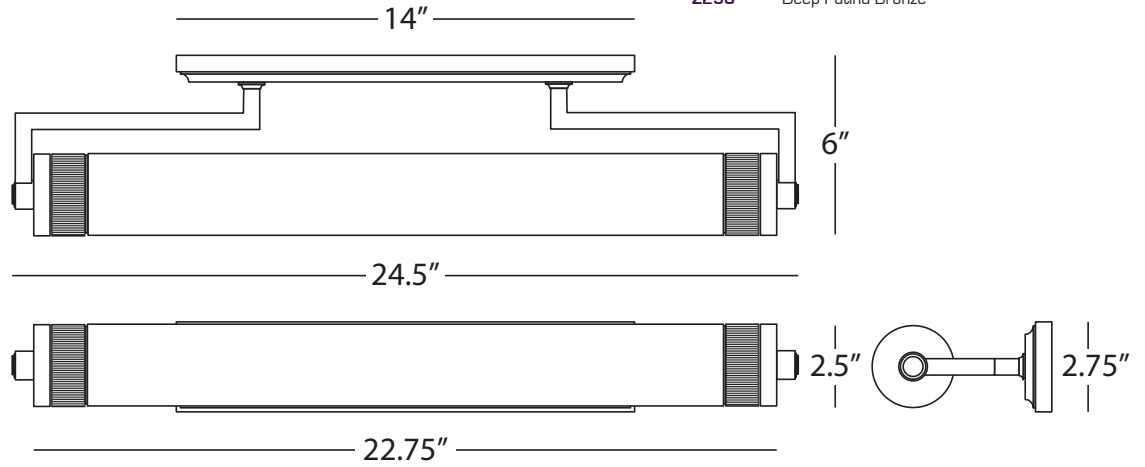

WYATT

**S251**

18" Picture Light

2 - 25W Max.  
 Bulb Type: B, Medium Base  
 Switch: On-Off Line Switch  
 24" Cord Cover/Direct Wire  
 Polished Nickel Finish  
 Metal Shade

FINISH OPTIONS:

- 251** Modern Brass
- Z251** Deep Patina Bronze



2433

Zoltar

ZOLTAR

**2433**  
Large Pendant

6 - 25W Max.  
Bulb Type: B, Candelabra  
Direct Wire  
Antique Brass Finish  
Clear Glass Shade  
Susp. Hardware: 3 pcs. 5/8" x 12"  
& 1 pc. 5/8" x 6" Extensions

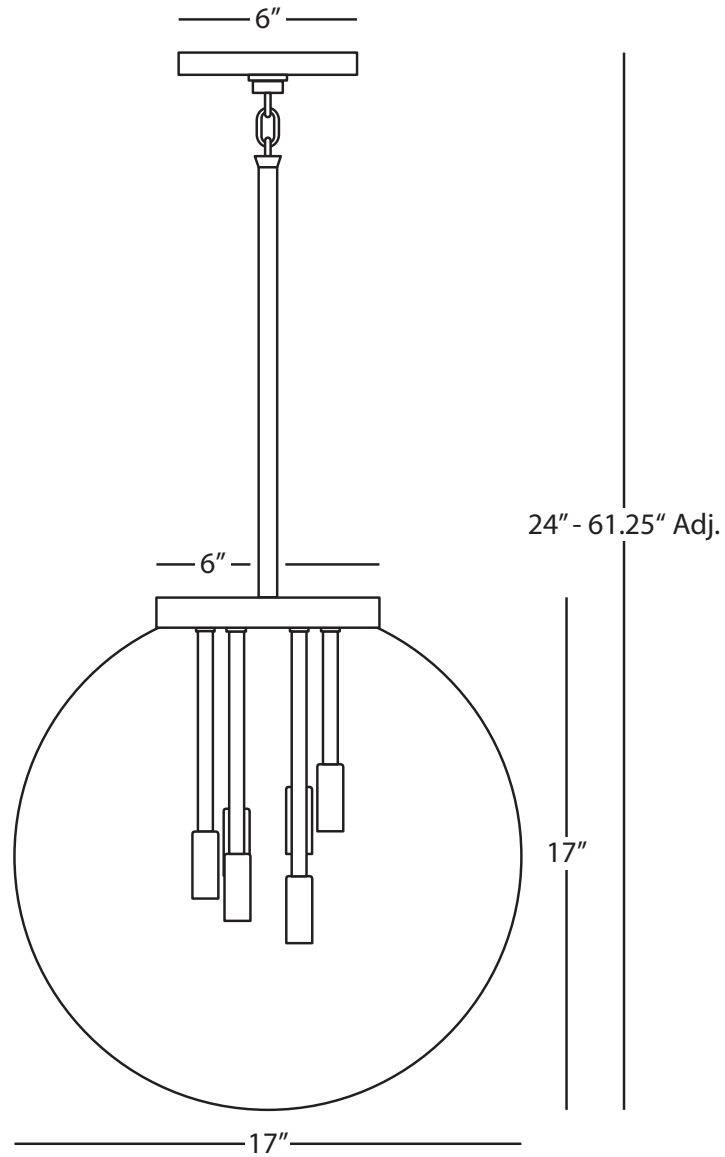

## RICO ESPINET

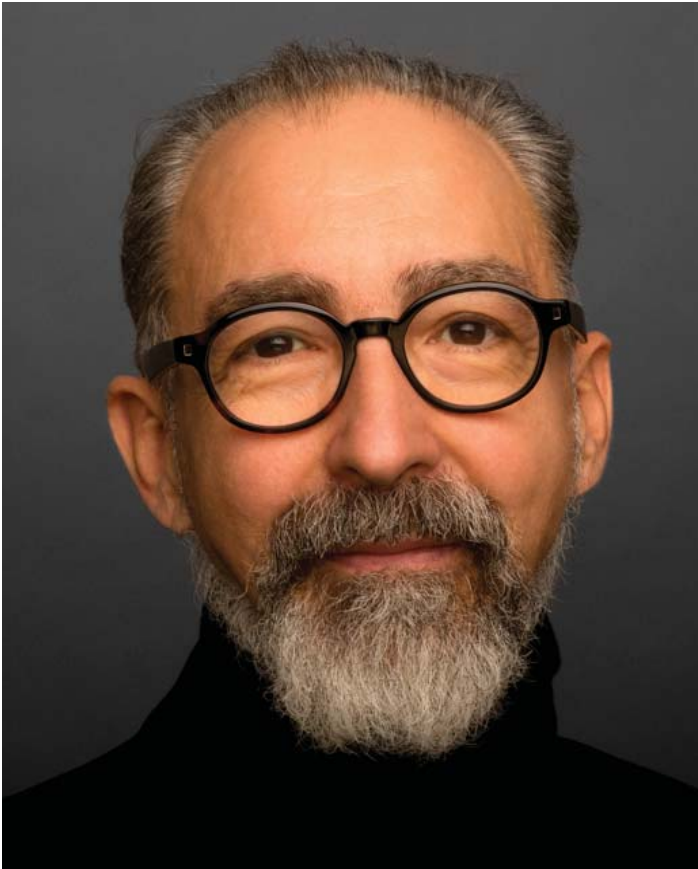

Photograph by Joe Gaffney

Rico Espinet is known for creating striking, poetic environments that combine clean lines and simple forms. Reflecting his training as a sculptor and a preoccupation with personal interiors, Rico's design sensibility is grounded in materials and values that endure. He mixes furnishings, lighting, accessories, industrial objects and fine art to create comfortable yet extraordinary spaces. His popular Robert Abbey Lighting collections feature warm, often atmospheric light inspired by the beauty of everyday objects.



1580W



2068

RICO ESPINET



615



1595



2058



615



Z614



S614

# Rico Espinet Arial

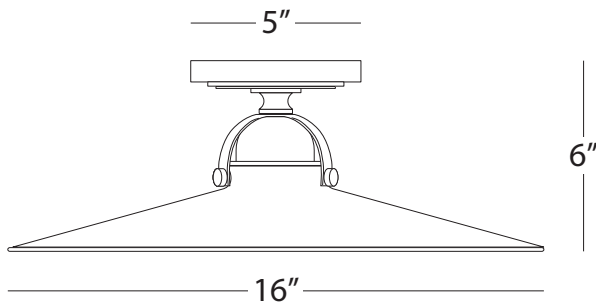

RICO ESPINET ARIAL

## S614

Flush Mount

1 - 100W Max.  
Bulb Type: A  
Direct Wire  
Antique Silver Finish  
White Glass Shade

FINISH OPTIONS:

**614** Warm Brass  
**Z614** Deep Patina Bronze

RICO ESPINET ARIAL

## 615

Pendant

1 - 100W Max.  
Bulb Type: A  
Direct Wire  
Warm Brass Finish  
White Glass Shade  
Susp. Hardware: 3 pcs. 5/8" x 12" &  
1 pc. 5/8" x 6" Extensions

FINISH OPTIONS:

**S615** Antique Silver  
**Z615** Deep Patina Bronze

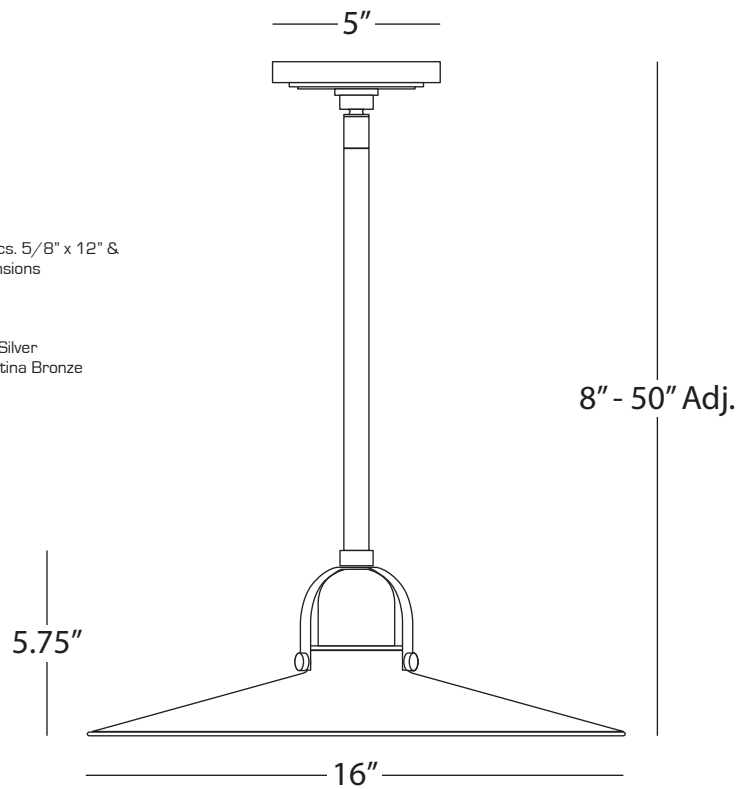

# Rico Espinet Bumper



610



D610



# Rico Espinet Bumper

RICO ESPINET BUMPER

**D610**

Pendant

1 - 150W Max.  
Bulb Type: G, Medium Base  
Direct Wire  
Dark Antique Nickel Finish w/  
Painted White Shade Interior  
Susp. Hardware: 1 pc. 5/8" x 6" &  
3 pcs. 5/8" x 12" Extensions

FINISH OPTIONS:

- 610** Warm Brass
- Z610** Deep Patina Bronze

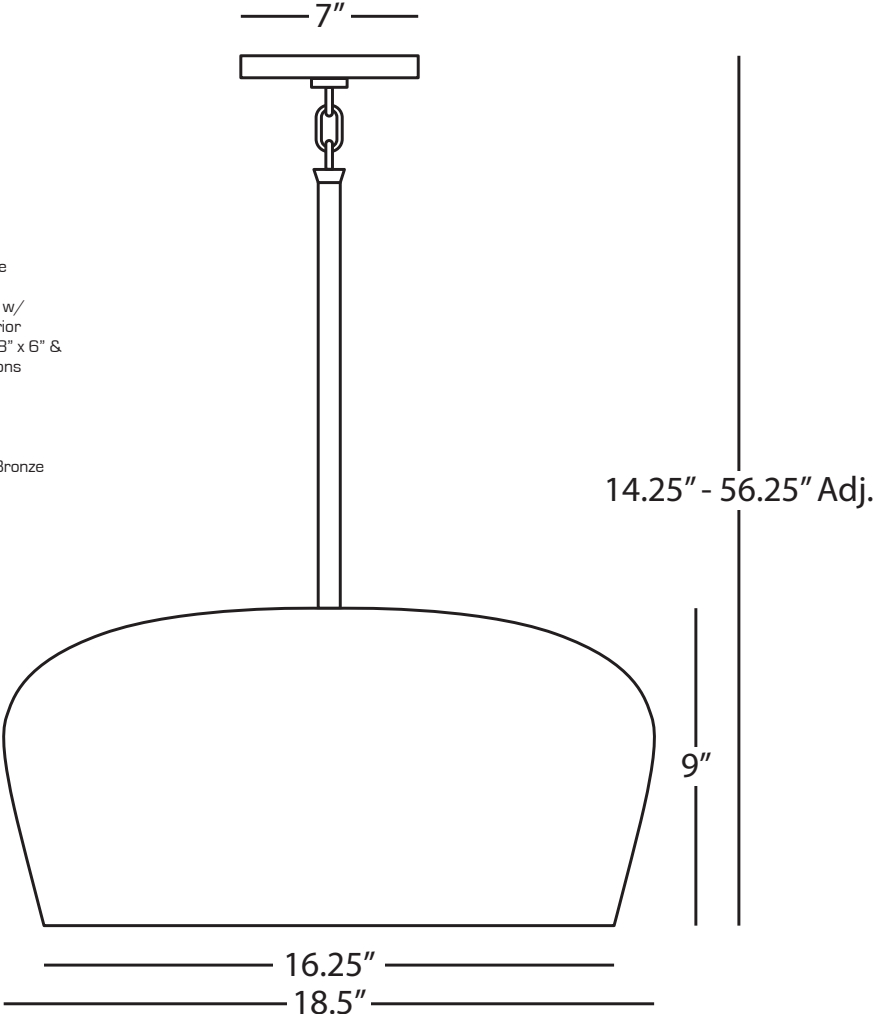

# Rico Espinet Buster



2083



2803W



2082



2056W



2075

# Rico Espinet Buster

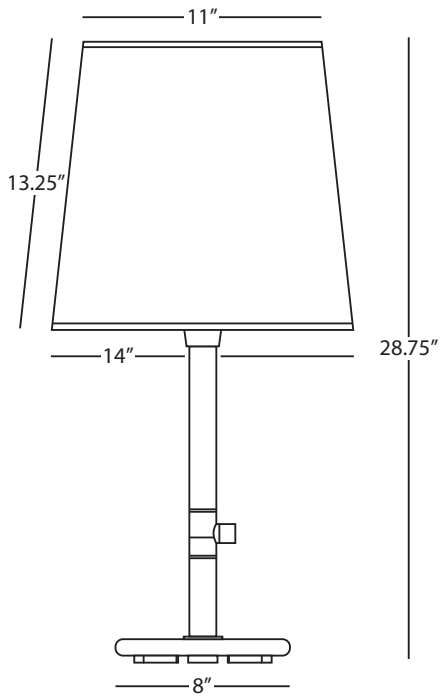

RICO ESPINET BUSTER

## 2083

### Accent Lamp

1 - 150W Max.  
 Bulb Type: A  
 Switch: Full Range Dimmer  
 Deep Patina Bronze Finish  
 Muslin Claiborne Fabric Shade

FINISH/SHADE OPTIONS:

- 2077** Polished Brass  
Smoke Gray Fabric
- 2077W** Polished Brass  
Ascot White Fabric
- 2082** Polished Nickel  
Taupe Claiborne Fabric
- 2082G** Polished Nickel  
Smoke Gray Fabric
- 2082W** Polished Nickel  
Fondine Fabric
- 2803** Aged Brass  
Smoke Gray Fabric
- 2803W** Aged Brass  
Fondine Fabric

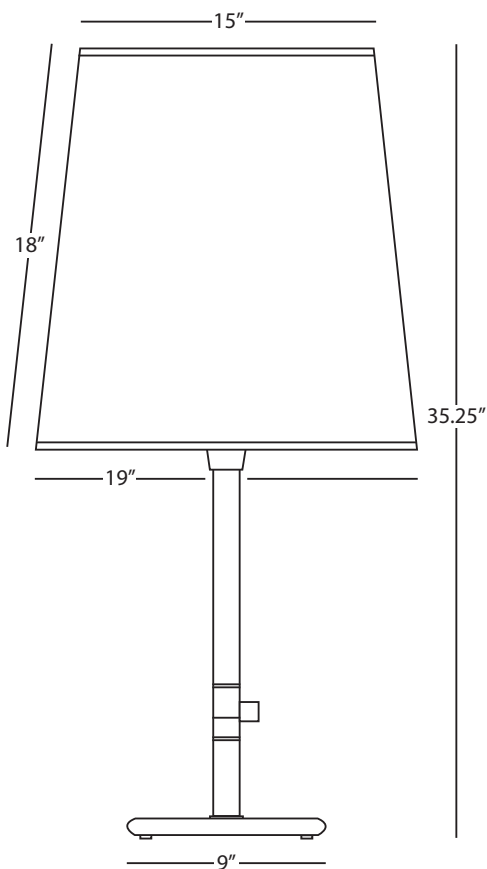

RICO ESPINET BUSTER

## 2056W

### Table Lamp

1 - 200W Max.  
 Bulb Type: A  
 Switch: Full Range Dimmer  
 Polished Nickel Finish  
 Fondine Fabric Shade

FINISH/SHADE OPTIONS:

- 2056** Polished Nickel  
Taupe Claiborne Fabric
- 2056G** Polished Nickel  
Smoke Gray Fabric
- 2075** Polished Brass  
Smoke Gray Fabric
- 2075W** Polished Brass  
Ascot White Fabric
- 2800** Aged Brass  
Smoke Gray Fabric
- 2800W** Aged Brass  
Fondine Fabric

# Rico Espinet Buster



2055G



Z2057



2804W



2079W

# Rico Espinet Buster

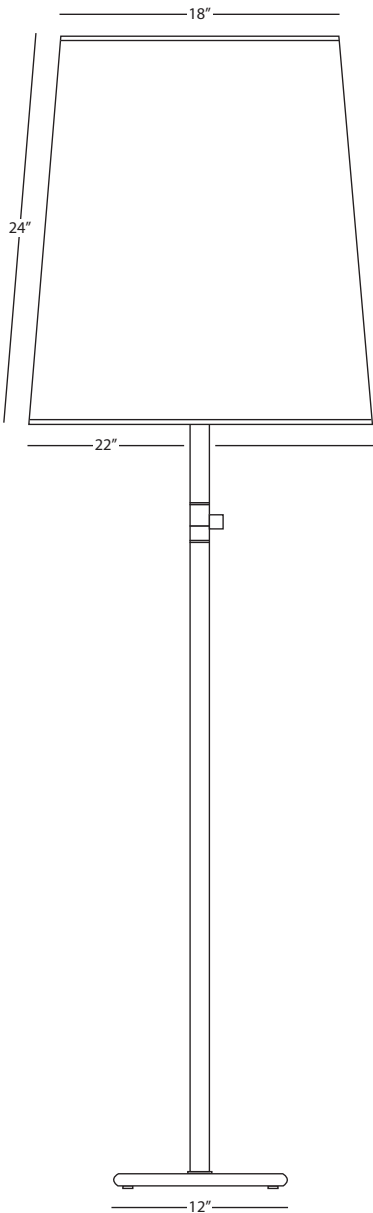

RICO ESPINET BUSTER

## Z2057 Floor Lamp

1 - 200W Max.  
Bulb Type: A  
Switch: Full Range Dimmer  
Deep Patina Bronze Finish  
Muslin Claiborne Fabric Shade

- FINISH/SHADE OPTIONS:
- 2057** Polished Nickel  
Taupe Claiborne Fabric
  - 2057G** Polished Nickel  
Smoke Gray Fabric
  - 2057W** Polished Nickel  
Fondine Fabric
  - 2076** Polished Brass  
Smoke Gray Fabric
  - 2076W** Polished Brass  
Ascot White Fabric
  - 2801** Aged Brass  
Smoke Gray Fabric
  - 2801W** Aged Brass  
Fondine Fabric

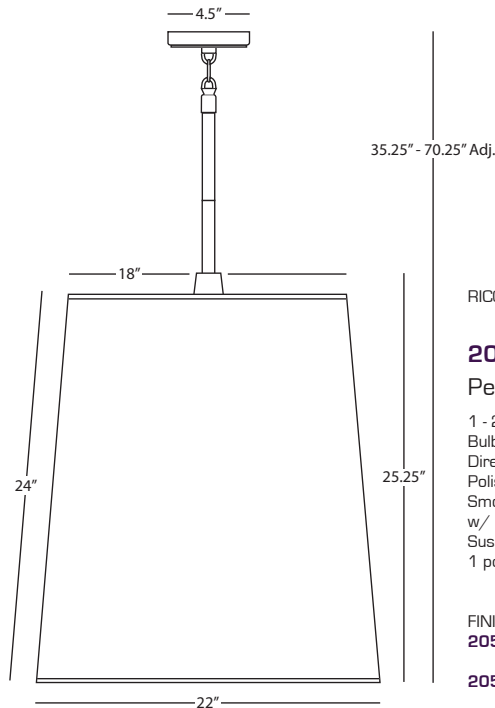

RICO ESPINET BUSTER

## 2055G Pendant

1 - 200W Max.  
Bulb Type: A  
Direct Wire  
Polished Nickel Finish  
Smoke Gray Fabric Shade  
w/ Self-Fabric Diffuser  
Susp. Hardware: 3 pcs. 5/8" x 12" &  
1 pc. 5/8" x 6" Extensions

- FINISH/SHADE OPTIONS:
- 2055** Polished Nickel  
Taupe Claiborne Fabric
  - 2055W** Polished Nickel  
Fondine Fabric
  - 2079** Polished Brass  
Smoke Gray Fabric
  - 2079W** Polished Brass  
Ascot White Fabric
  - 2802** Aged Brass  
Smoke Gray Fabric
  - 2802W** Aged Brass  
Fondine Fabric

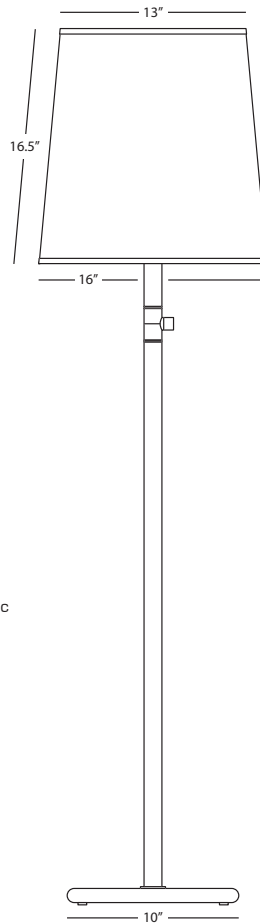

RICO ESPINET BUSTER

## 2804W Chica Floor Lamp

1 - 150W Max.  
Bulb Type: A  
Switch: Full Range Dimmer  
Aged Brass Finish  
Fondine Fabric Shade

- FINISH/SHADE OPTIONS:
- 2078** Polished Brass  
Smoke Gray Fabric
  - 2078W** Polished Brass  
Ascot White Fabric
  - 2080** Polished Nickel  
Taupe Claiborne Fabric
  - 2080G** Polished Nickel  
Smoke Gray Fabric
  - 2080W** Polished Nickel  
Fondine Fabric
  - 2081** Deep Patina Bronze  
Muslin Claiborne
  - 2804** Aged Brass  
Smoke Gray Fabric

# Rico Espinet Candelaria



Z2091



Z2099

# Rico Espinet Candelaria

RICO ESPINET CANDELARIA

## Z2099

### 2-Tier Chandelier

30 - 40W Max.  
Bulb Type: A  
Direct Wire Only  
Deep Patina Bronze Finish  
Susp. Hardware: 3 pcs. 5/8" x 12"  
& 1 pc. 5/8" x 6" Extensions

Photographed with Historical Bulbs  
SOLD SEPARATELY  
(BUL30 See Page 225)

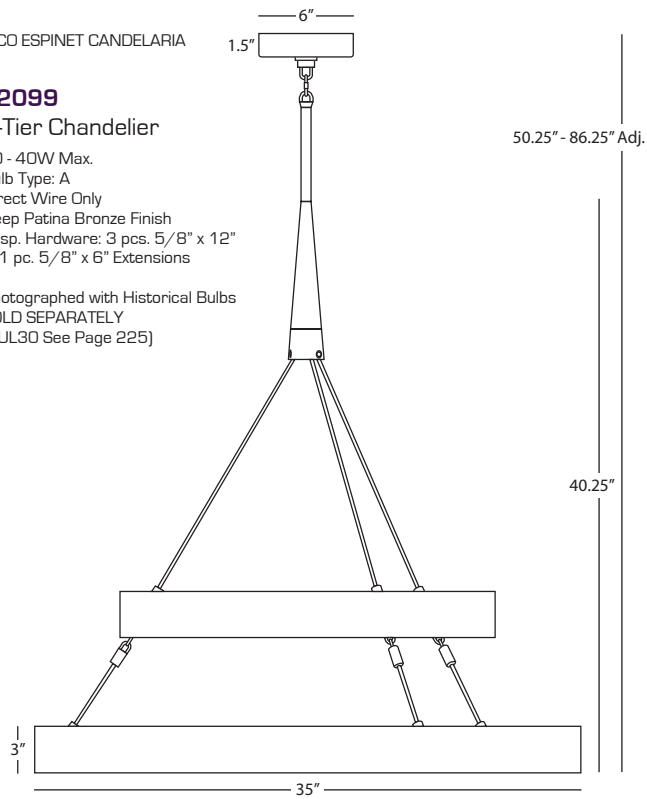

RICO ESPINET CANDELARIA

## Z2091

### Large Chandelier

18 - 40W Max.  
Bulb Type: A  
Direct Wire Only  
Deep Patina Bronze Finish  
Susp. Hardware: 3 pcs. 5/8" x 12"  
& 1 pc. 5/8" x 6" Extensions

Photographed with Historical Bulbs  
SOLD SEPARATELY  
(BUL18 See Page 225)

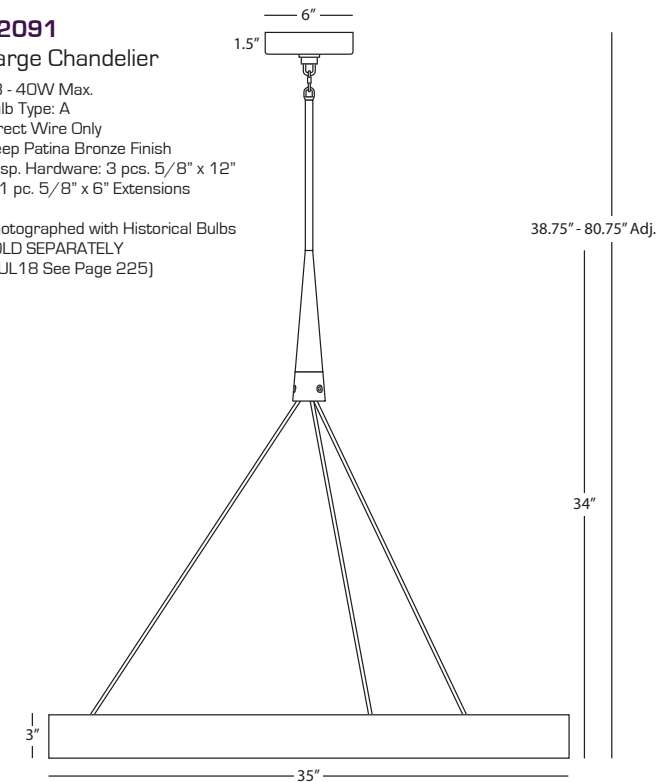

## Rico Espinet Lua Vessel

---



1595



# Rico Espinet Lua Vessel

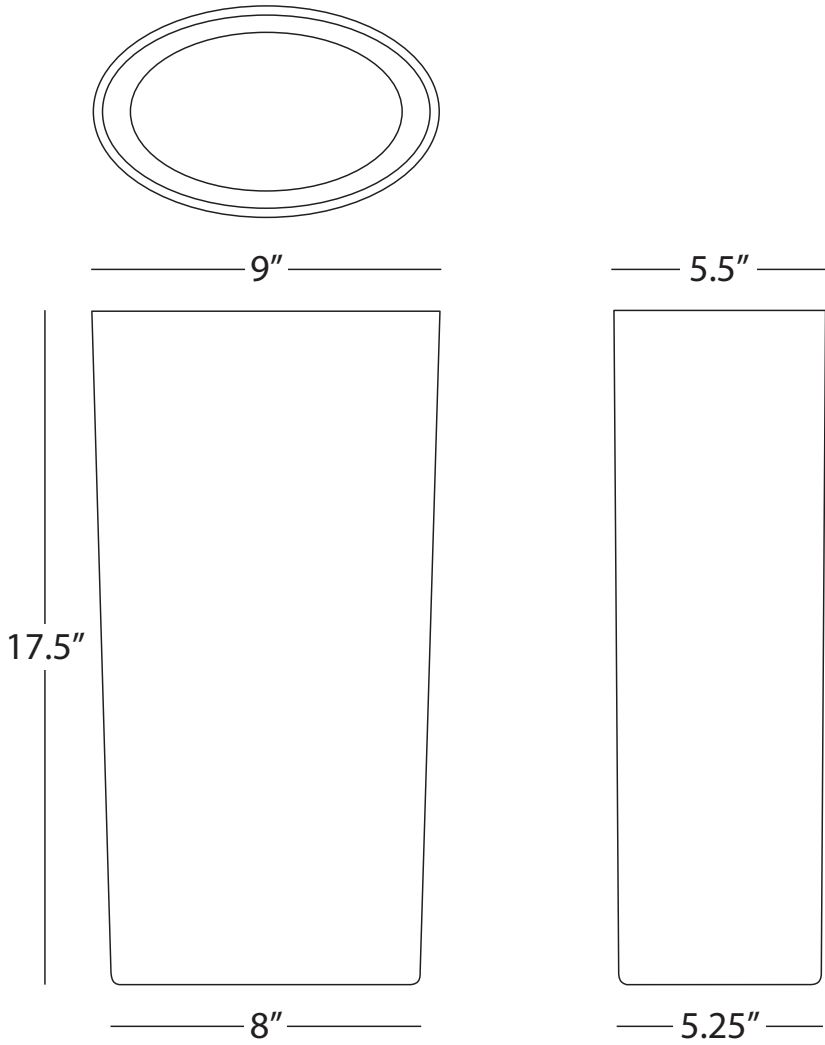

RICO ESPINET LUA VESSEL

**1595**

Accent Torchiere

- 1 - 150W Max.
- Bulb Type: A
- Switch: Hi-Lo Line Switch
- Oval White Cased Glass



1591

# Rico Espinet Marina

RICO ESPINET MARINA

**1591**  
Table Torchiere  
1 - 60W Max.  
Bulb Type: T10 Tubular  
Switch: Full Range Line Dimmer  
Frosted White Cased Glass

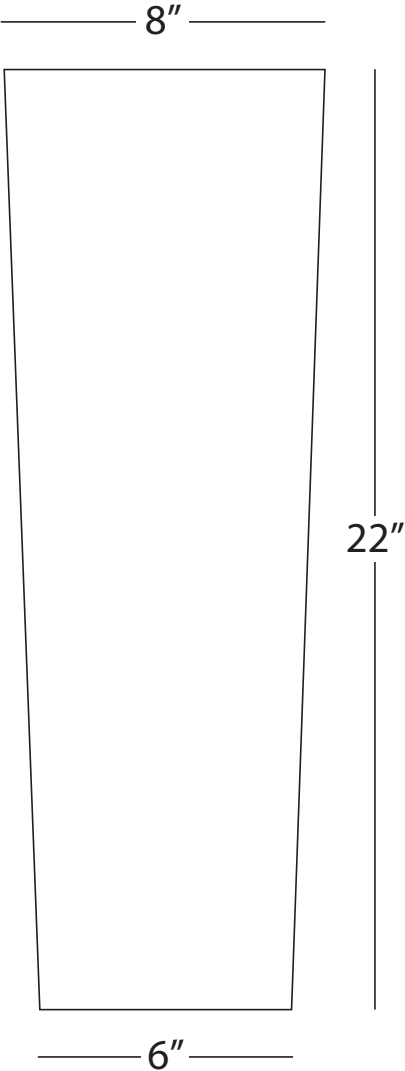



B2097

B2098

# Rico Espinet Miles

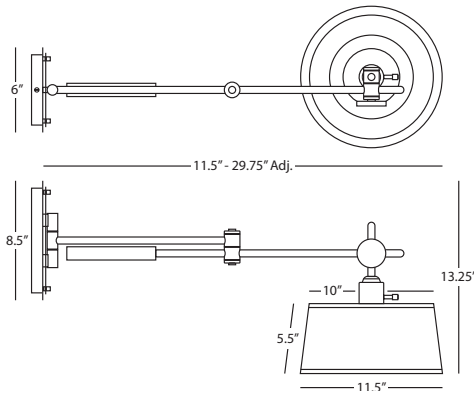

RICO ESPINET MILES

## B2098 Wall Mounted Boom Lamp

1 - 100W Max.  
Bulb Type: A  
Switch: Hi-Lo Dimming  
24" Cord Cover/Direct Wire  
Brushed Nickel Finish  
Concrete Painted Finish over Iron Base  
Open Weave White Linen Shade w/  
Self-Fabric Diffuser

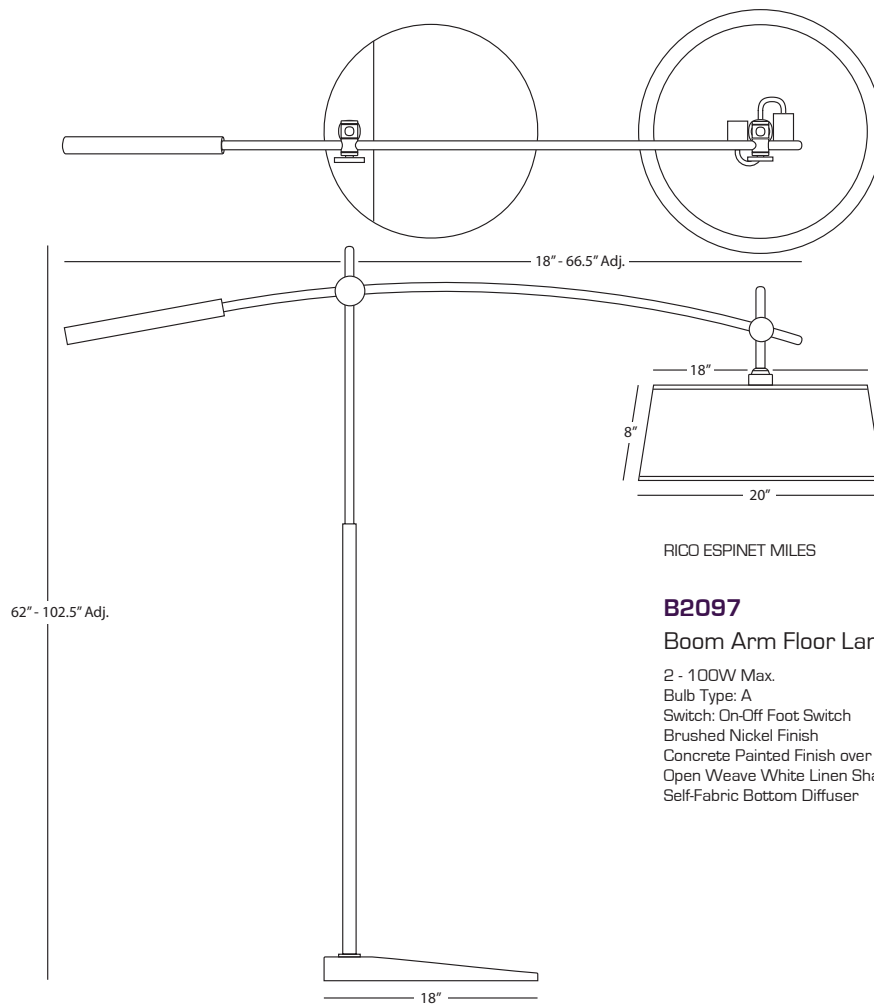

RICO ESPINET MILES

## B2097 Boom Arm Floor Lamp

2 - 100W Max.  
Bulb Type: A  
Switch: On-Off Foot Switch  
Brushed Nickel Finish  
Concrete Painted Finish over Iron Base  
Open Weave White Linen Shade w/  
Self-Fabric Bottom Diffuser

# Rico Espinet Nina



Z2068



Z2058



2043



2069

# Rico Espinet Nina

RICO ESPINET NINA

## 2043 Flush Mount

1 - 100W Max.  
Bulb Type: A  
Direct Wire Only  
Polished Nickel Finish  
Frosted White Cased Glass Shade

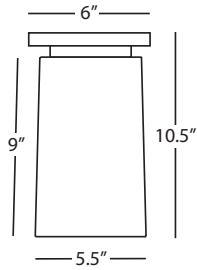

FINISH OPTION:

**22043** Deep Patina Bronze

RICO ESPINET NINA

## 22058 Corta Flush Mount

1 - 60W Max.  
Bulb Type: B11 Torpedo  
Direct Wire Only  
Deep Patina Bronze Finish  
Frosted White Cased Glass Shade

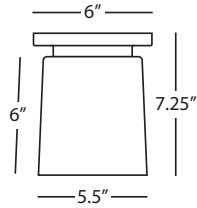

FINISH OPTION:

**2058** Polished Nickel

RICO ESPINET NINA

## 2069 Table Torchiere

1 - 150W Max.  
Bulb Type: A  
Switch: Full Range Dimmer  
Polished Nickel Finish  
White Frosted Cased Glass Shade

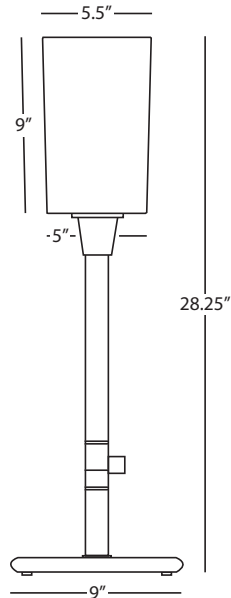

RICO ESPINET NINA

## 22068 Floor Torchiere

1 - 150W Max.  
Bulb Type: A  
Switch: Full Range Dimmer  
Deep Patina Bronze Finish  
White Frosted Cased Glass Shade

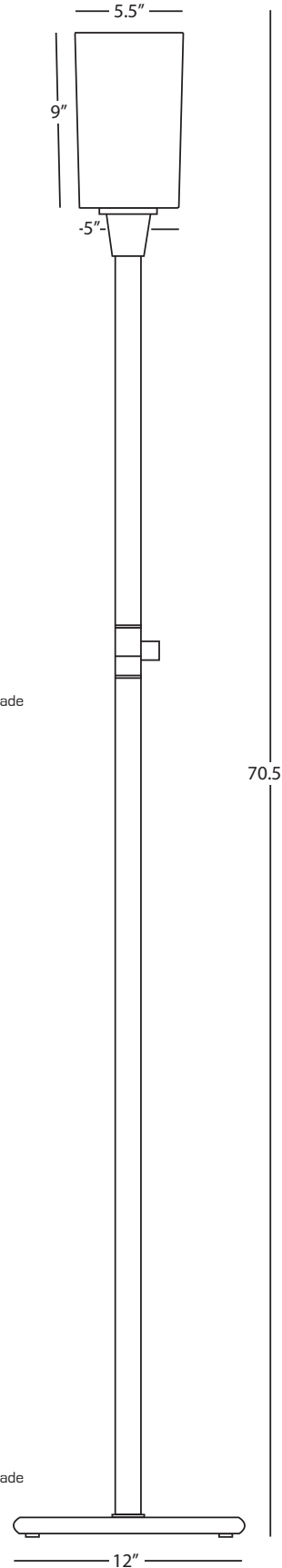

FINISH OPTION:

**2068** Polished Nickel

# Rico Espinet Olinda



1580W



1581B



1578B



1578W



# Rico Espinet Olinda

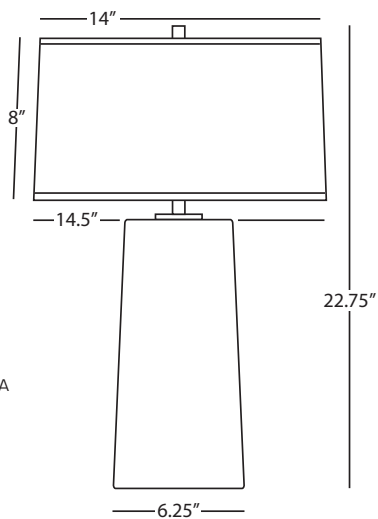

RICO ESPINET OLINDA

## 1580W Accent Lamp

1 - 100W Max  
Bulb Type: A  
1 - 7.5W Max. for Night Light Feature  
Bulb Type: 7C7 Candelabra  
Switch: 4-Way  
Frosted White Cased Glass Base w/  
Night Light  
White Organza Fabric Shade w/  
Self-Fabric Top Diffuser

SHADE OPTION:  
**1580B** Black Organza

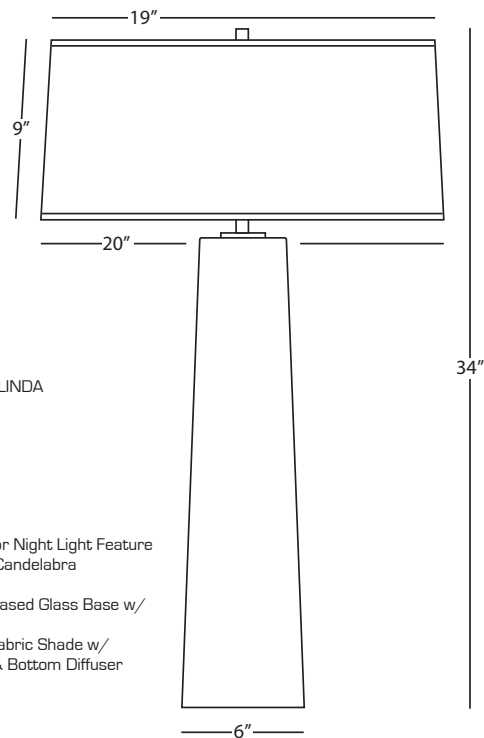

RICO ESPINET OLINDA

## 1578B Table Lamp

1 - 100W Max  
Bulb Type: A  
1 - 7.5W Max. for Night Light Feature  
Bulb Type: 7C7 Candelabra  
Switch: 4-Way  
Frosted White Cased Glass Base w/  
Night Light  
Black Organza Fabric Shade w/  
Self-Fabric Top & Bottom Diffuser

SHADE OPTION:  
**1578W** White Organza

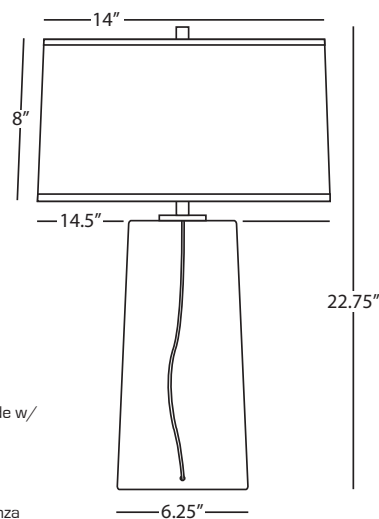

RICO ESPINET OLINDA

## 1581B Accent Lamp

1 - 100W Max  
Bulb Type: A  
Switch: Hi-Lo Dimming  
Clear Glass Base  
Black Organza Fabric Shade w/  
Self-Fabric Top Diffuser

SHADE OPTION:  
**1581W** White Organza

# Rico Espinet Ovo



Z2045



2044

# Rico Espinet Ovo

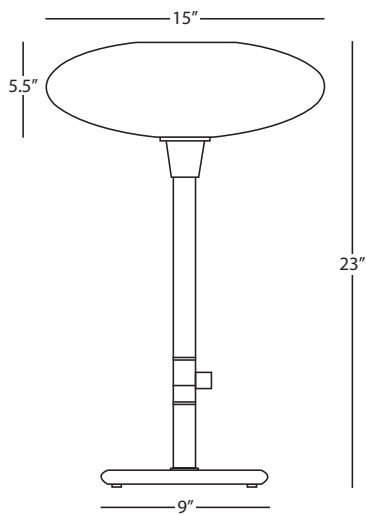

RICO ESPINET OVO

## 2044

### Table Lamp

1 - 150W Max.  
Bulb Type: A  
Switch: Full Range Dimmer  
Polished Nickel Finish  
Frosted White Cased Glass Shade

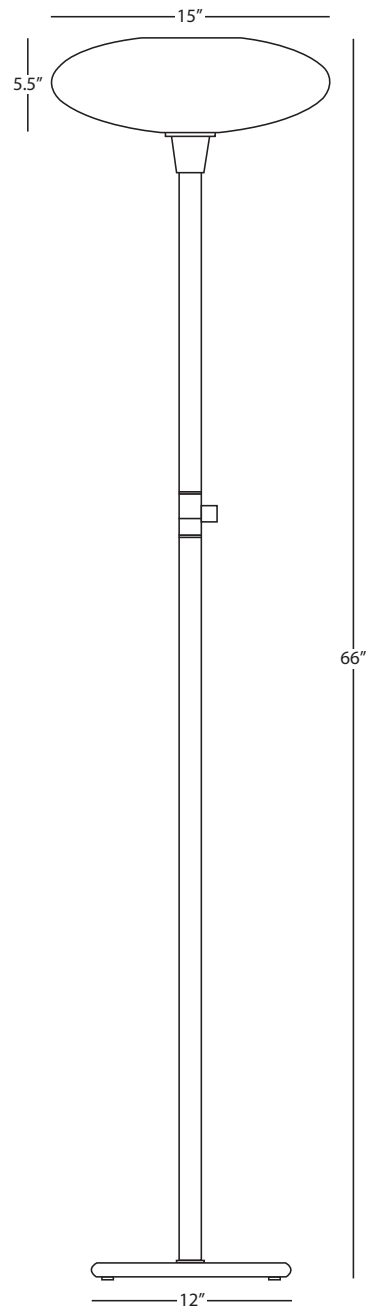

RICO ESPINET OVO

## Z2045

### Floor Torchiere

1 - 150W Max.  
Bulb Type: A  
Switch: Full Range Dimmer  
Deep Patina Bronze  
Frosted White Cased Glass Shade

FINISH OPTION:

**2045** Polished Nickel

# Rico Espinet Racer



1522

# Rico Espinet Racer

RICO ESPINET RACER

**1522**

Chandelier

5 - 100W Max.

Bulb Type: A

Direct Wire

Modern Brass Finish

Matte Black Adjustable Shades

Susp. Hardware: 1 pc. 5/8" x 6" & 3 pcs.

5/8" x 12" Extensions

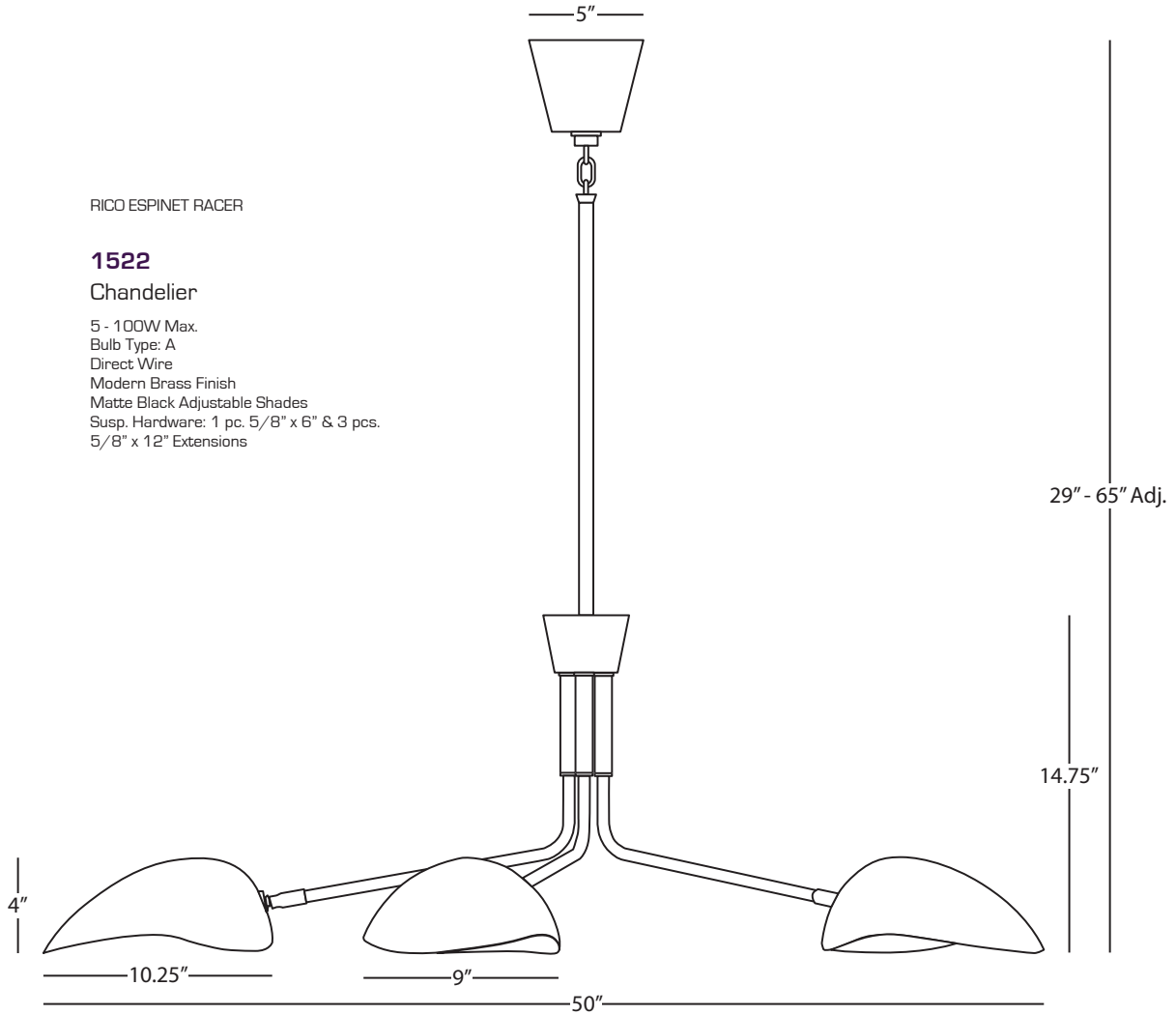

# Rico Espinet Scout



S248



248

# Rico Espinet Scout

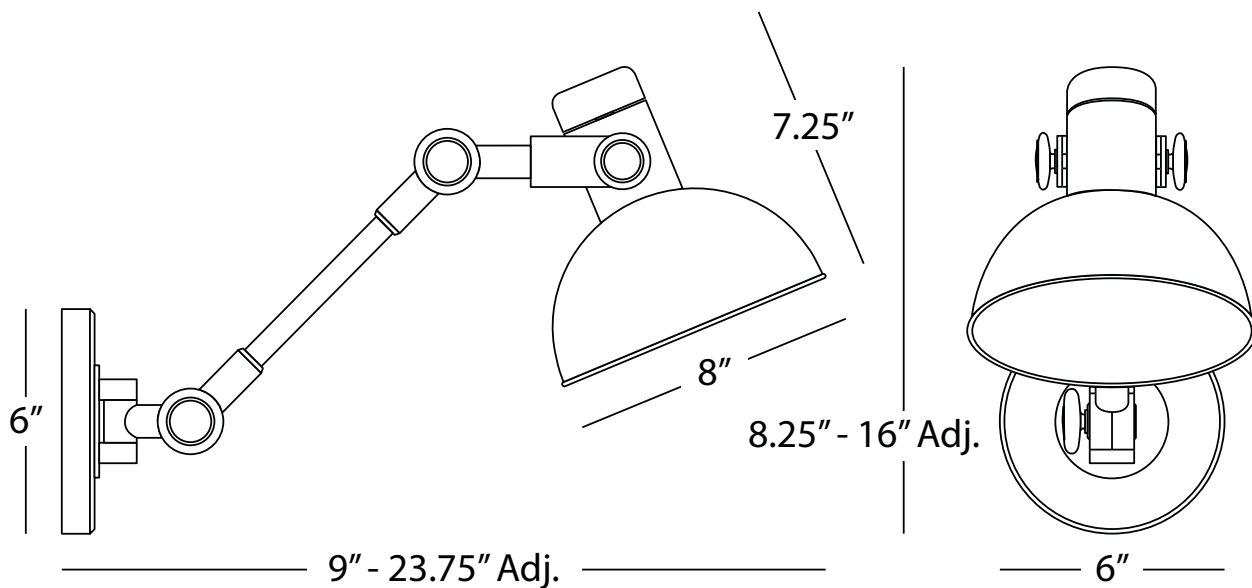

RICO ESPINET SCOUT

**248**

Adjustable Wall Sconce

1 - 60W Max.  
Bulb Type: A  
Switch: Hi-Lo Dimming  
24" Cord Cover/Direct Wire  
Antique Brass Finish  
Adjustable Metal Shade

FINISH OPTION:

**S248** Polished Nickel

# Rico Espinet Shinto



2171



# Rico Espinet Shinto

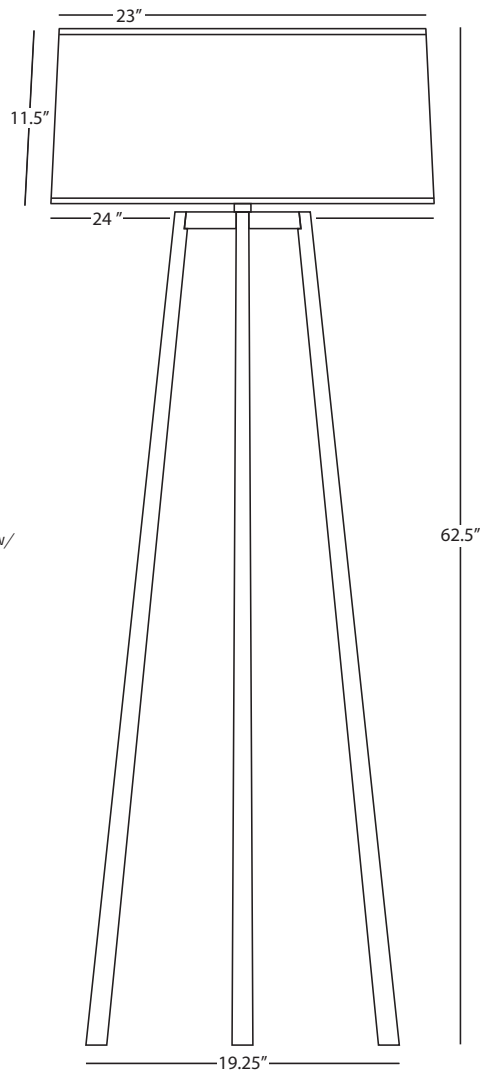
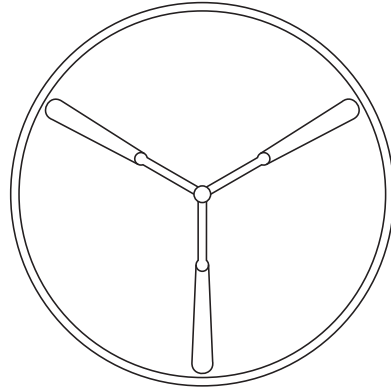

RICO ESPINET SHINTO

## 2171

### Tripod Floor Lamp

1 - 150W Max.  
Bulb Type: A  
Switch: 3-Way  
Wrought Iron Finish  
Ascot White Fabric Shade w/  
Black Contrast Trim

# JONATHAN ADLER



Potter, designer, and author Jonathan Adler launched his namesake brand after leaving his day job to pursue his first love: pottery. In 1993, Barneys bought his collection, and five years later, he opened his first store in Soho.

Today his offerings span furniture, lighting, home décor, and more, plus countless iconic interior projects, and retail locations worldwide, all dedicated to bringing Modern American Glamour to your life.

Jonathan's design work can be found in top restaurants, hotels, and homes around the world.

The Jonathan Adler brand now has retail locations worldwide, a thriving e-commerce site, a full slate of residential and commercial projects, and a wholesale business boasting over 1,000 locations globally.



851B



687

# JONATHAN ADLER



902



S157



676



L911B



S475

476

BL475

# Jonathan Alder Biarritz

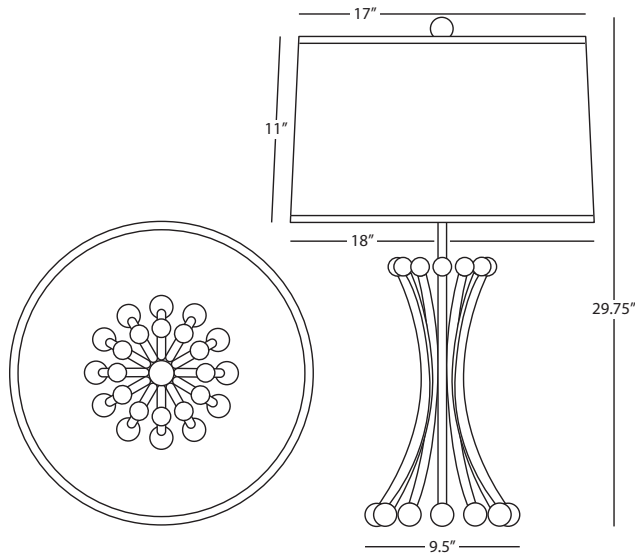

JONATHAN ADLER BIARRITZ

## BL475 Table Lamp

1 - 150W Max.  
Bulb Type: A  
Switch: Full Range Dimmer  
Blackened Metal Finish w/  
Polished Brass Accents  
Ascot White Fabric Shade

FINISH OPTIONS:

**475** Polished Brass  
**S475** Polished Nickel

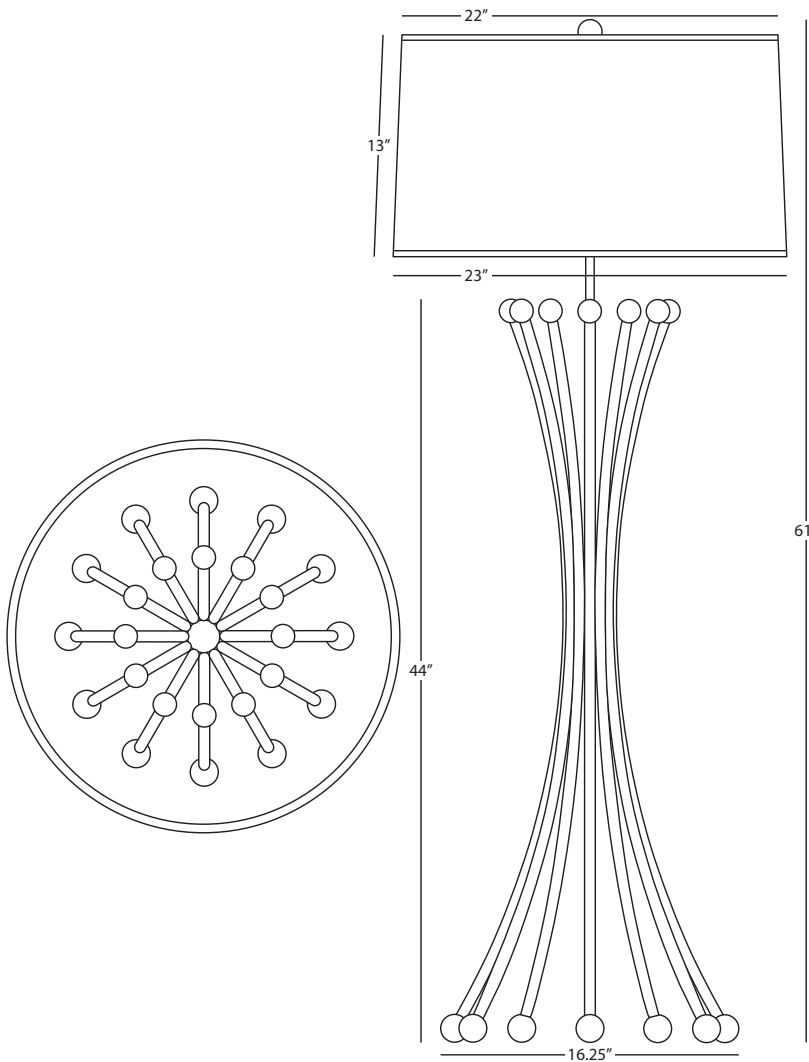

JONATHAN ADLER BIARRITZ

## 476 Floor Lamp

1 - 150W Max.  
Bulb Type: A  
Switch: Full Range Dimmer  
Polished Brass Finish  
Ascot White Fabric Shade

FINISH OPTIONS:

**BL476** Blackened Metal w/  
Polished Brass Accents  
**S476** Polished Nickel

# Jonathan Adler Bristol



S875



706

robertabbey.com



S707



707

# Jonathan Adler Bristol

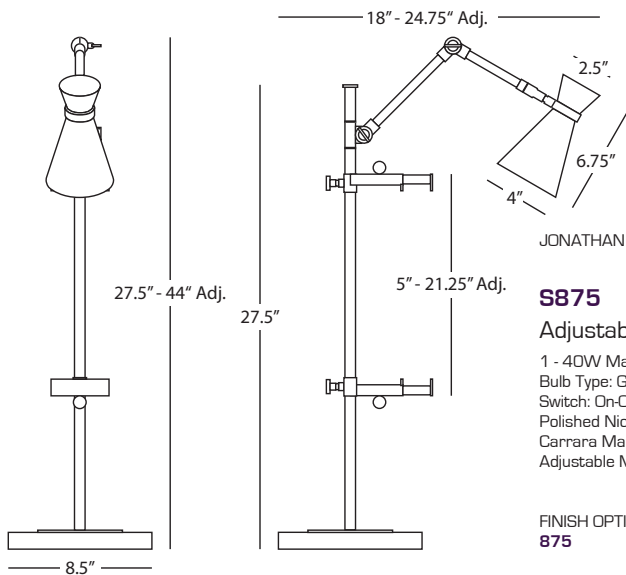

JONATHAN ADLER BRISTOL

## S875

### Adjustable Table Easel w/ Lamp

1 - 40W Max.  
 Bulb Type: G16.5, Candelabra Base  
 Switch: On-Off Line Switch  
 Polished Nickel Finish  
 Carrara Marble Base  
 Adjustable Metal Shade

#### FINISH OPTION:

**875** Antique Brass  
 Honed Travertine Base

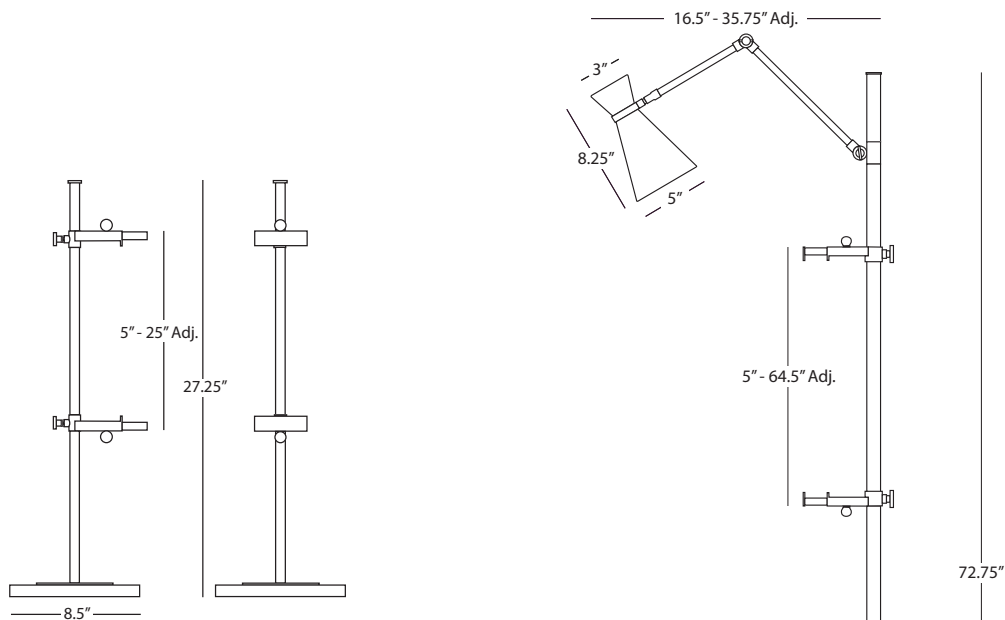

JONATHAN ADLER BRISTOL

## 707

### Adjustable Table Easel

Antique Brass Finish  
 Honed Travertine Base

#### FINISH OPTION:

**S707** Polished Nickel  
 Carrara Marble Base

JONATHAN ADLER BRISTOL

## 706

### Adjustable Floor Easel

1 - 60W Max.  
 Bulb Type: B11 Torpedo  
 Switch: Hi-Lo  
 Antique Brass Finish  
 Honed Travertine Base  
 Adjustable Metal Shade

#### FINISH OPTION:

**S706** Polished Nickel  
 Carrara Marble Base

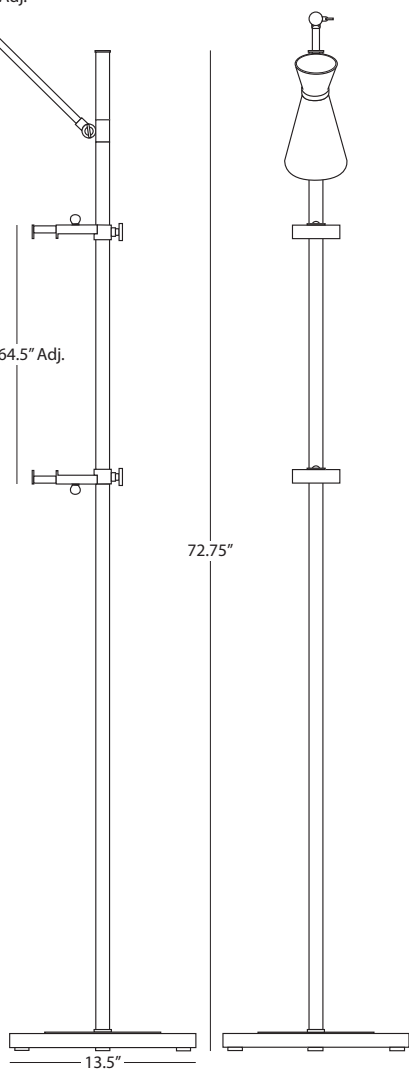

# Jonathan Adler Canaan



795X



B796X



796



# Jonathan Adler Canaan

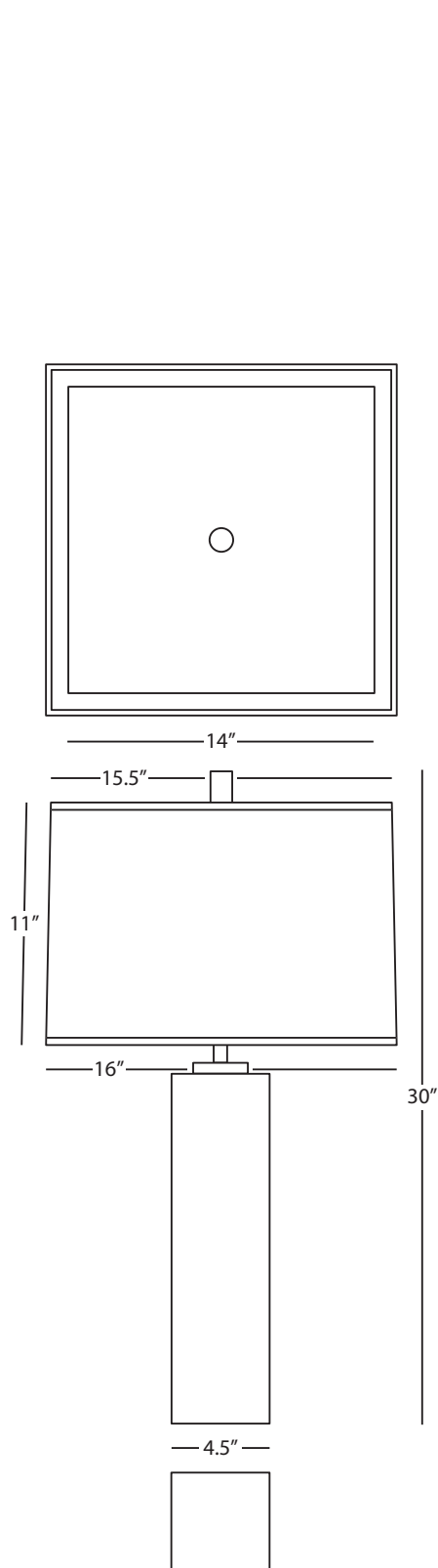

JONATHAN ADLER CANAAN

## 796

### Table Lamp

1 - 150W Max.  
 Bulb Type: A  
 Switch: Hi-Lo Dimming  
 Carrara Marble Base  
 Antique Brass Accents  
 Square Oyster Linen Shade w/  
 Perforated Metal Top Diffuser  
 Black Fabric Wrapped Cord

#### FINISH/SHADE OPTIONS:

**796X** Carrara Marble  
 Smoke Gray Fabric  
**B796** Black Marble  
 White Brussels Linen  
**B796X** Black Marble  
 Black Opaque Parchment  
 w/ White Lining

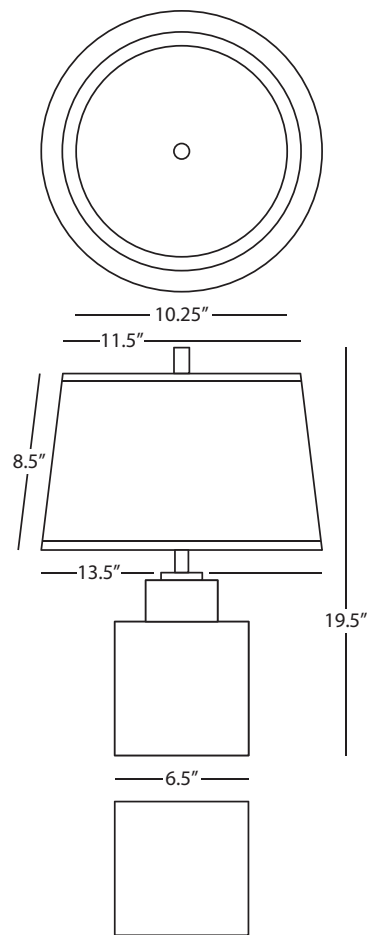

JONATHAN ADLER CANAAN

## 795X

### Accent Lamp

1 - 100W Max.  
 Bulb Type: A  
 Switch: Hi-Lo Dimming  
 Carrara Marble Base  
 Antique Brass Accents  
 Smoke Gray Fabric Shade w/  
 Perforated Metal Top Diffuser  
 Black Fabric Wrapped Cord

#### SHADE OPTION:

**795** Oyster Linen

Jonathan Adler Canaan



680



889



851B

# Jonathan Adler Canaan

JONATHAN ADLER CANAAN

## 889 Shift Table Lamp

1 - 150W Max.  
 Bulb Type: A  
 Switch: Hi-Lo Dimming  
 Carrara and Black Marble Base  
 Antique Brass Accents  
 Oyster Linen Fabric Shade  
 Perforated Metal Top Diffuser  
 Black Fabric Wrapped Cord

SHADE OPTION:

**889B** Black Opaque Parchment  
 w/ White Lining

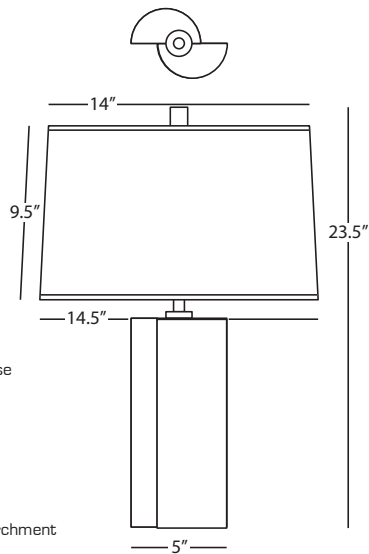

JONATHAN ADLER CANAAN

## 851B Tapered Table Lamp

1 - 150W Max.  
 Bulb Type: A  
 Switch: Hi-Lo Dimming Line Switch  
 Carrara and Black Marble Base  
 Antique Brass Accents  
 Black Opaque Parchment Shade w/  
 White Lining  
 Black Fabric Wrapped Cord

SHADE OPTION:

**851** Oyster Linen

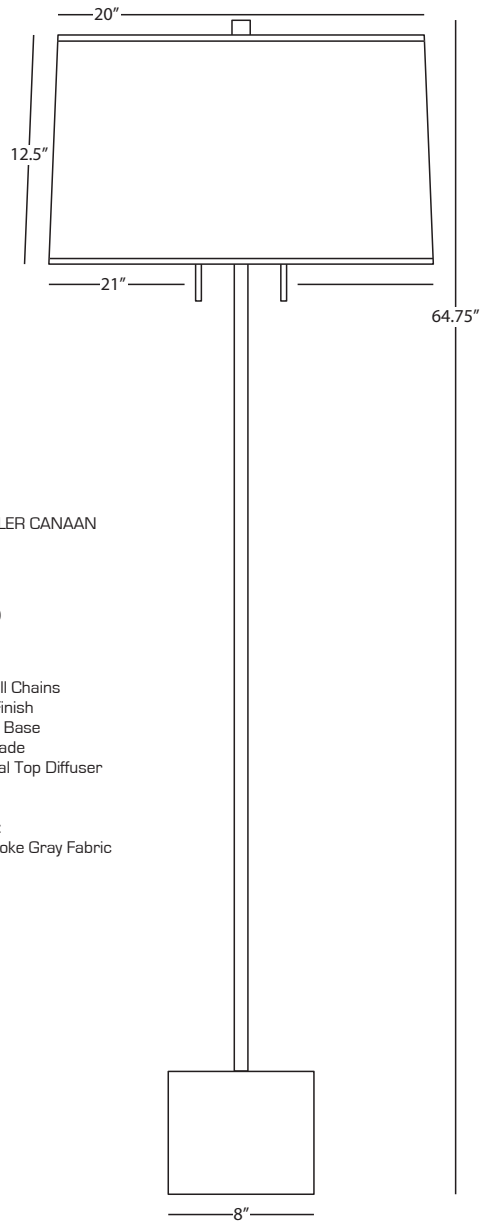
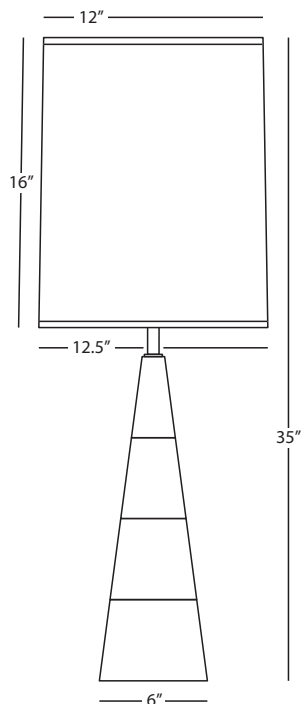

JONATHAN ADLER CANAAN

## 680 Floor Lamp

2 - 150W Max.  
 Bulb Type: A  
 Switch: Hi-Lo Pull Chains  
 Antique Brass Finish  
 Carrara Marble Base  
 Oyster Linen Shade  
 Perforated Metal Top Diffuser

SHADE OPTION:

**680G** Smoke Gray Fabric

# Jonathan Adler Capri



WH734



WH737



WH738



WH730



WH736

# Jonathan Adler Capri

JONATHAN ADLER CAPRI

## WH736

### Accent Lamp

1 - 150W Max.  
 Bulb Type: A  
 Switch: 3-Way  
 White Cased Glass w/  
 Polished Nickel Accents  
 Translucent Ceramiko Blanco  
 Parchment Shade

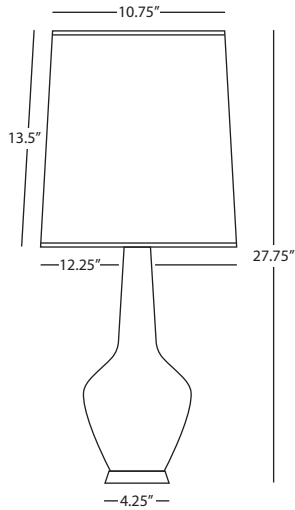

JONATHAN ADLER CAPRI

## WH734

### Pendant

1 - 100W Max.  
 Bulb Type: A  
 Direct Wire Only  
 White Cased Glass w/  
 Polished Nickel Accents  
 Susp. Hardware: 11 Ft. White Cord

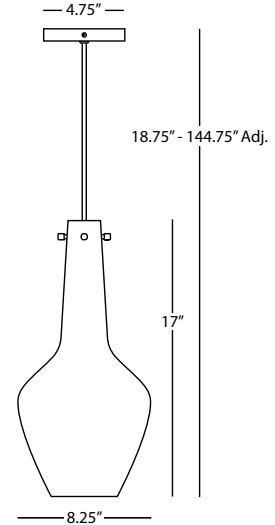

JONATHAN ADLER CAPRI

## WH737

### Accent Torchiere

1 - 150W Max.  
 Bulb Type: A  
 Switch: 3-Way  
 Walnut Finished Wood Base w/  
 Polished Nickel Accents  
 White Cased Glass Shade

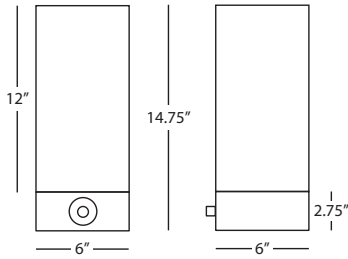

JONATHAN ADLER CAPRI

## WH738

### Torchiere

1 - 150W Max.  
 Bulb Type: A  
 Switch: 3-Way  
 Walnut Finished Wood Base w/  
 Polished Nickel Accents  
 White Cased Glass Shade

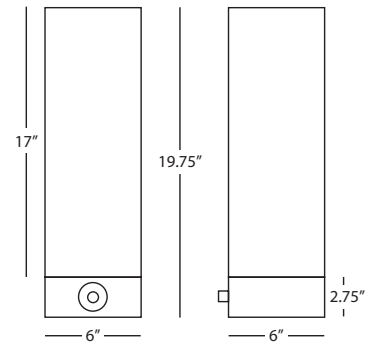

JONATHAN ADLER CAPRI

## WH730

### Tall Table Lamp

1 - 150W Max.  
 Bulb Type: A  
 Switch: Full Range Dimmer  
 White Cased Glass w/  
 Polished Nickel Accents  
 Translucent Ceramiko Blanco  
 Parchment Shade

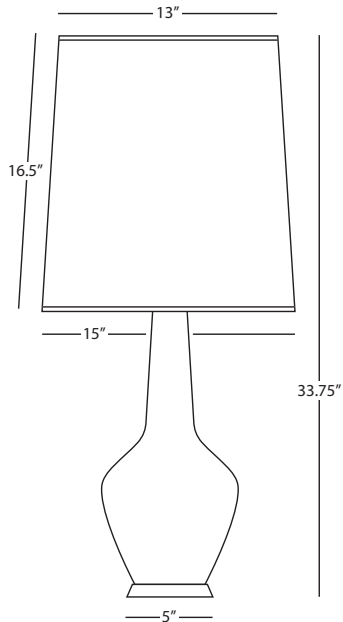



732



730L



730R

# Jonathan Adler Ceramic

JONATHAN ADLER CERAMIC

**732**

Lantern Wall Sconce

1 - 60W Max.  
 Bulb Type: A  
 Direct Wire Only  
 Ceramic w/ White Glaze Finish  
 White Linen Fabric Shade w/  
 Rolled Edge Hem  
 ADA Compliant

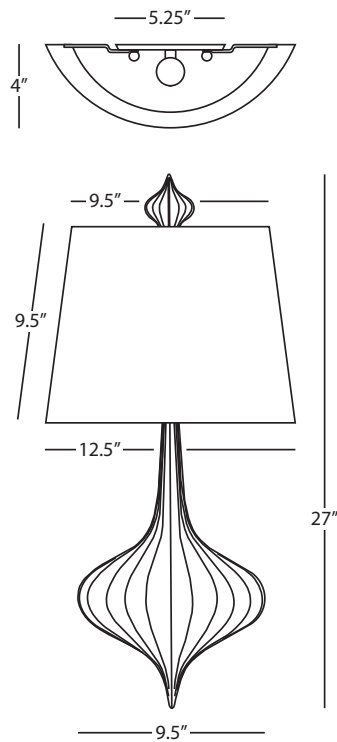

JONATHAN ADLER CERAMIC

**730L**

Giraffe Wall Sconce (Left Facing)

1 - 60W Max.  
 Bulb Type: A  
 Direct Wire Only  
 Ceramic w/ White Glaze Finish  
 White Linen Fabric Shade w/  
 Rolled Edge Hem  
 ADA Compliant

OPTION:

**730R** Giraffe Wall Sconce (Right Facing)

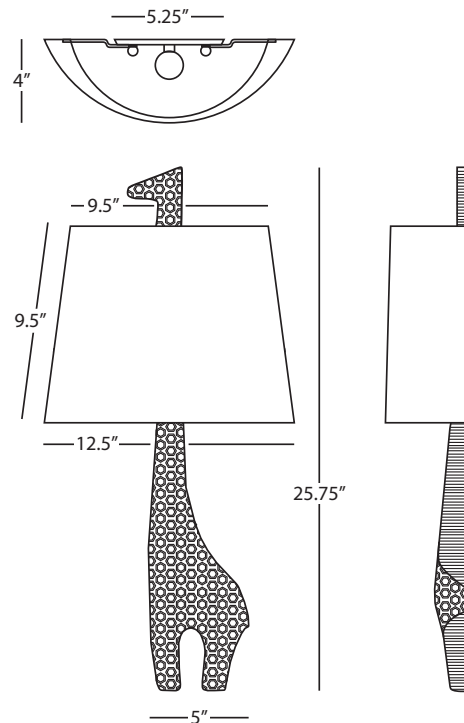



677



676



684B



# Jonathan Adler Claridge

JONATHAN ADLER CLARIDGE

## 684B

### Mini Tear Drop Accent Lamp

1 - 40W Max.  
 Bulb Type: B, Candelabra  
 Switch: Hi-Lo Line Switch  
 Lead Crystal w/ Polished Nickel Accents  
 Black Silk Dupioni Shade w/ Rolled Edge Hem

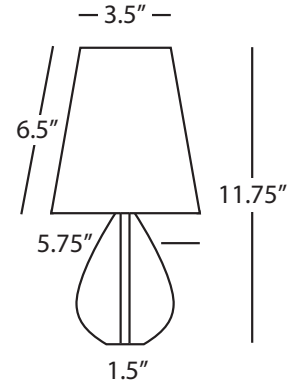

SHADE OPTION:

**684** Oyster Gray Silk Dupioni w/ Rolled Edge Hem

JONATHAN ADLER CLARIDGE

## 677

### Component Table Lamp

1 - 100W Max.  
 Bulb Type: A  
 Switch: Full Range Dimmer  
 Lead Crystal w/ Polished Nickel Accents  
 Oyster Gray Silk Dupioni Shade w/ Rolled Edge Hem

SHADE OPTION:

**677B** Black Silk Dupioni w/ Rolled Edge Hem

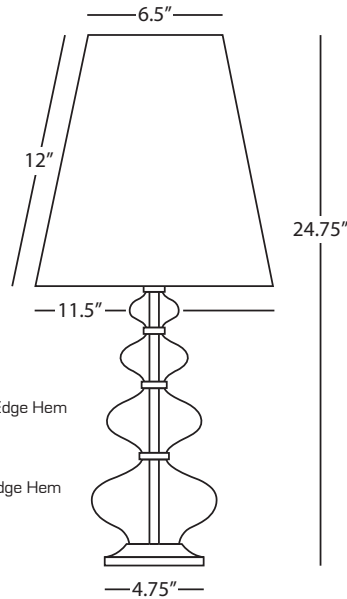

JONATHAN ADLER CLARIDGE

## 676

### Tear Drop Table Lamp

1 - 100W Max.  
 Bulb Type: A  
 Switch: Full Range Dimmer  
 Lead Crystal w/ Polished Nickel Accents  
 Oyster Gray Silk Dupioni Shade w/  
 Rolled Edge Hem

SHADE OPTION:

**676B** Black Silk Dupioni w/ Rolled Edge Hem

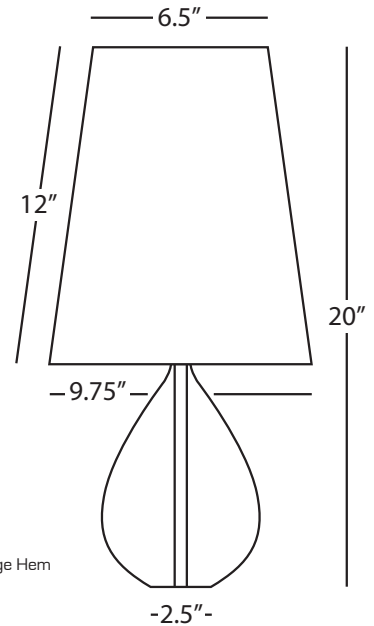

# Jonathan Adler Geneva



925



S925

# Jonathan Adler Geneva

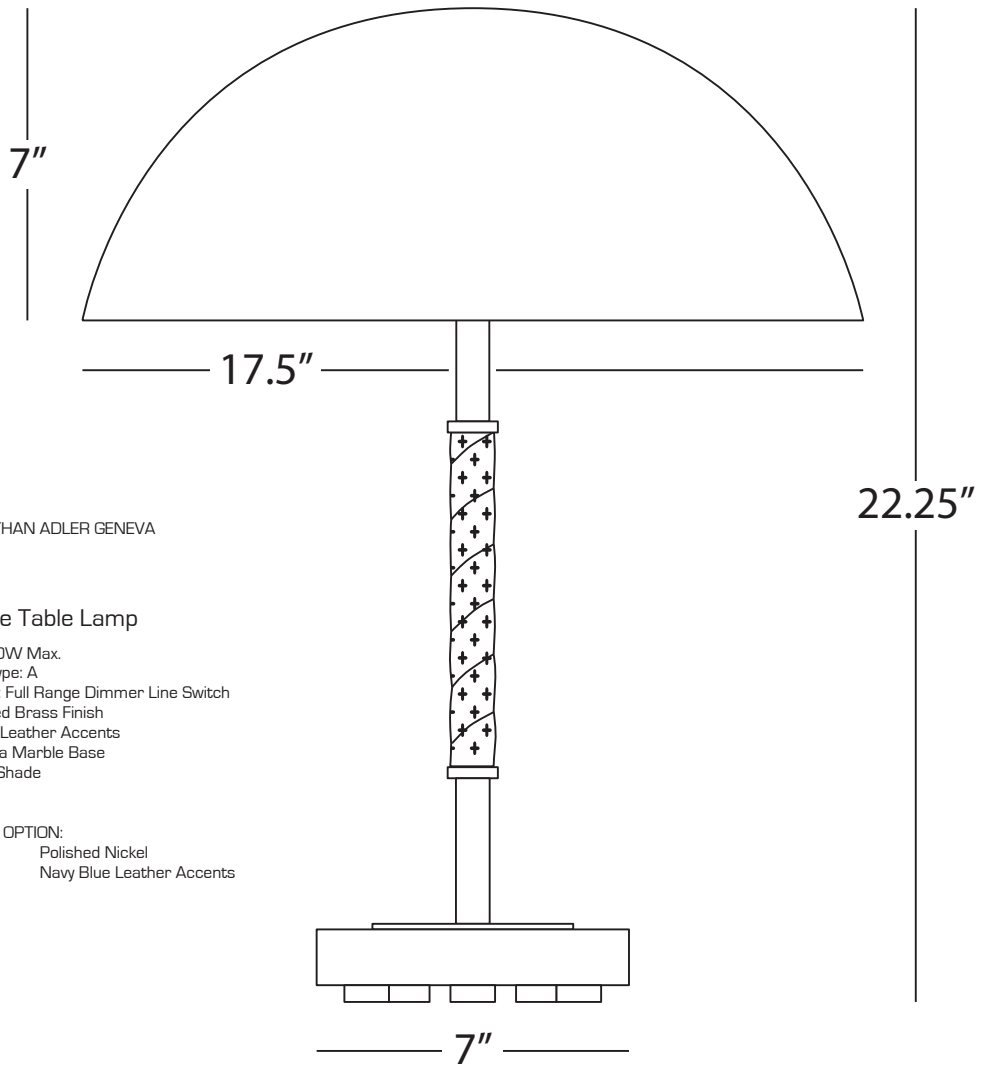

JONATHAN ADLER GENEVA

**925**

Dome Table Lamp

2 - 100W Max.

Bulb Type: A

Switch: Full Range Dimmer Line Switch

Polished Brass Finish

Camel Leather Accents

Carrara Marble Base

Metal Shade

FINISH OPTION:

**S925** Polished Nickel

Navy Blue Leather Accents

# Jonathan Adler Harlequin



787



786



S786



S787

# Jonathan Adler Harlequin

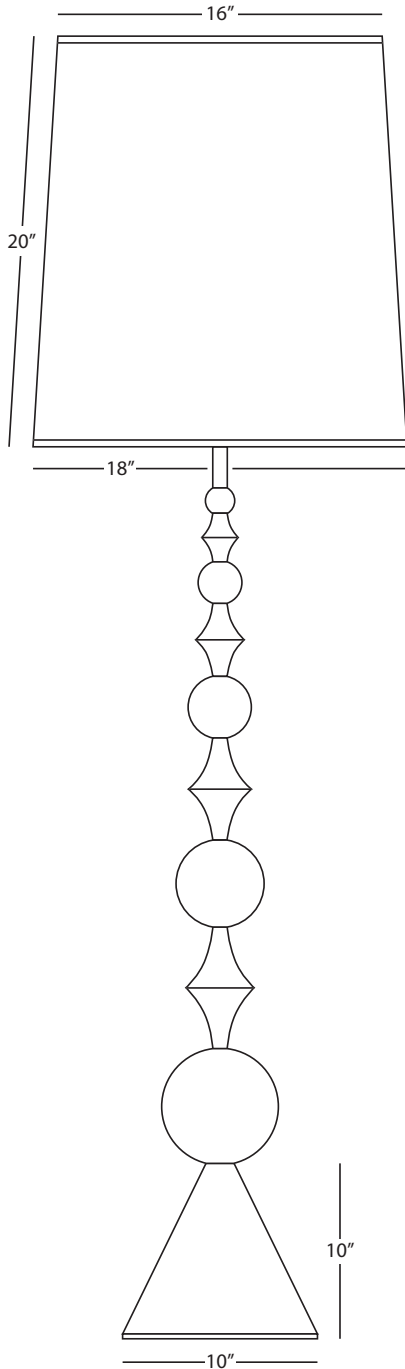

JONATHAN ADLER HARLEQUIN

**787**

Floor Lamp

1 - 150W Max.  
Bulb Type: A  
Switch: Hi-Lo Dimming  
Antique Brass Finish  
Oyster Linen Shade

FINISH OPTION:

**S787** Polished Nickel

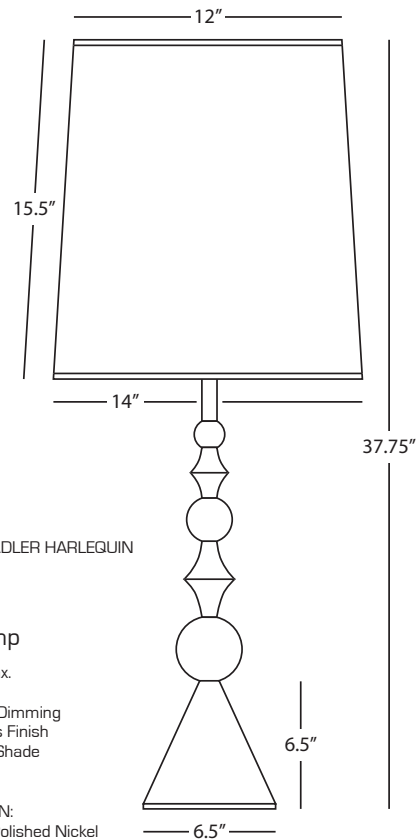

JONATHAN ADLER HARLEQUIN

**786**

Table Lamp

1 - 150W Max.  
Bulb Type: A  
Switch: Hi-Lo Dimming  
Antique Brass Finish  
Oyster Linen Shade

FINISH OPTION:

**S786** Polished Nickel

# Jonathan Adler Havana



W695



W698



W697



W708

# Jonathan Adler Havana

JONATHAN ADLER HAVANA

## W708

### Double Sconce

2 - 60W Max.  
 Bulb Type: A  
 Switch: Hi-Lo Line Switch  
 24" Cord Cover/Direct Wire  
 Polished Nickel Finish  
 Powder Coat White Metal Shades w/  
 Perforated Design

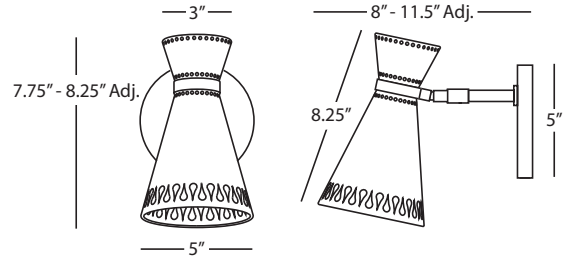
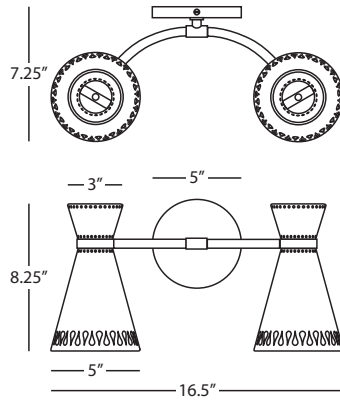

JONATHAN ADLER HAVANA

## W697

### Wall Sconce

1 - 60W Max.  
 Bulb Type: A  
 Switch: Hi-Lo Dimming  
 24" Cord Cover/Direct Wire  
 Polished Nickel Finish  
 Adjustable, Powder Coat White Metal Shade  
 w/ Perforated Design

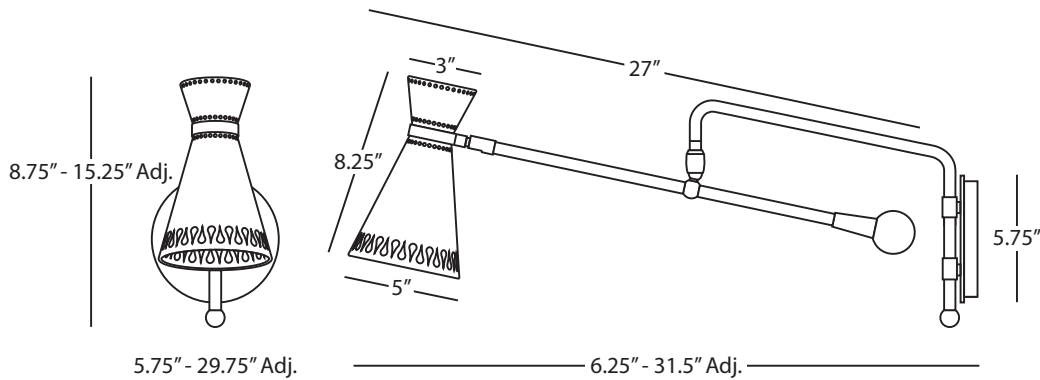

JONATHAN ADLER HAVANA

## W695

### Wall Boom Lamp

1 - 60W Max.  
 Bulb Type: A  
 Switch: Hi-Lo Rotary  
 24" Cord Cover/Direct Wire  
 Polished Nickel Finish  
 Adjustable, Powder Coat White Metal Shade w/  
 Perforated Design

JONATHAN ADLER HAVANA

## W698

### Double Shaded Half Round Sconce

2 - 60W Max.  
 Bulb Type: B, Candelabra  
 Direct Wire Only  
 Polished Nickel Finish  
 Powder Coat White Metal Shades w/ Perforated Design  
 ADA Compliant  
 \*Can Be Mounted Horizontally or Vertically\*

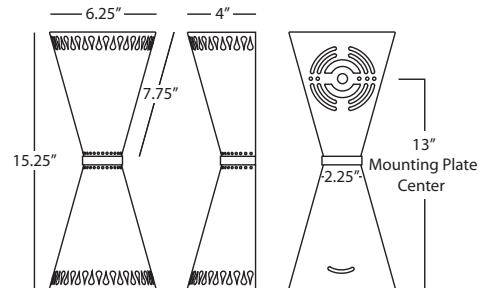



287



448



445



# Jonathan Adler Hollywood

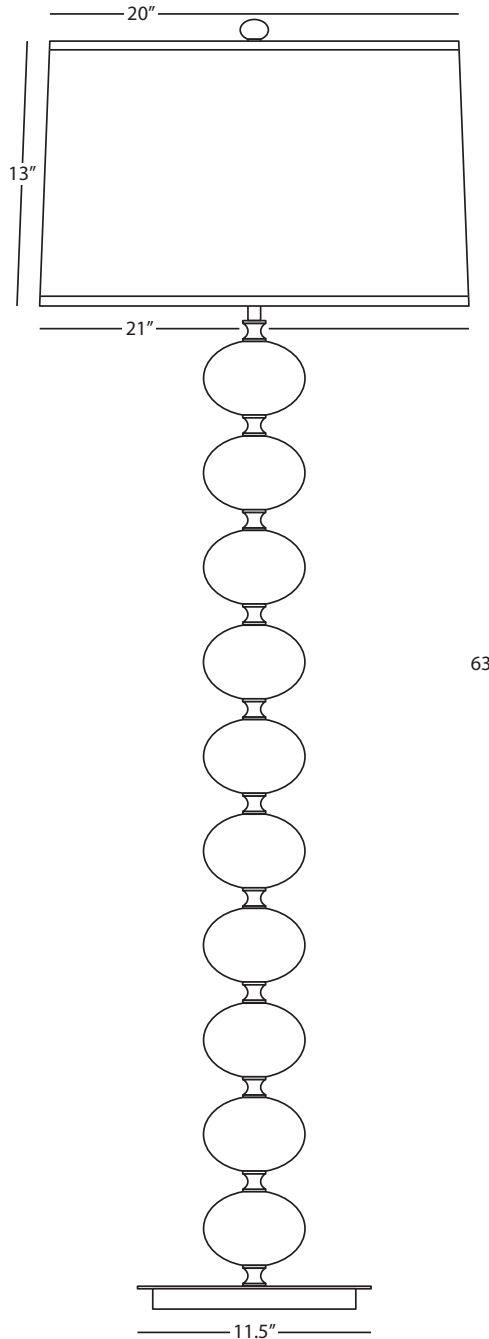

JONATHAN ADLER HOLLYWOOD

**445**

Havenhurst Table Lamp

1 - 150W Max.  
Bulb Type: A  
Switch: Full Range Dimmer  
Polished Brass Finish  
Oyster Linen Shade

FINISH OPTION:

**446** Polished Nickel

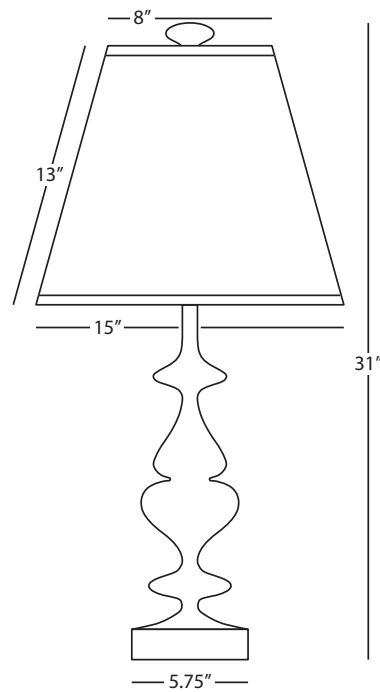

JONATHAN ADLER HOLLYWOOD

**448**

Floor Lamp

1 - 150W Max.  
Bulb Type: A  
Switch: Full Range Dimmer  
Polished Nickel Finish  
Oyster Linen Shade

FINISH OPTION:

**447** Polished Brass

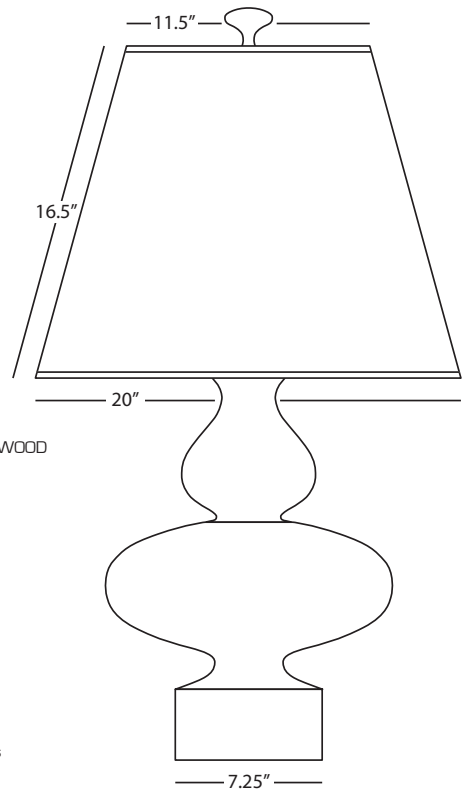

JONATHAN ADLER HOLLYWOOD

**286**

Bel Air Table Lamp

1 - 150W Max.  
Bulb Type: A  
Switch: Full Range Dimmer  
Polished Nickel Finish  
Oyster Linen Shade

FINISH OPTION:

**287** Polished Brass

# Jonathan Adler Jupiter



3542

# Jonathan Adler Jupiter

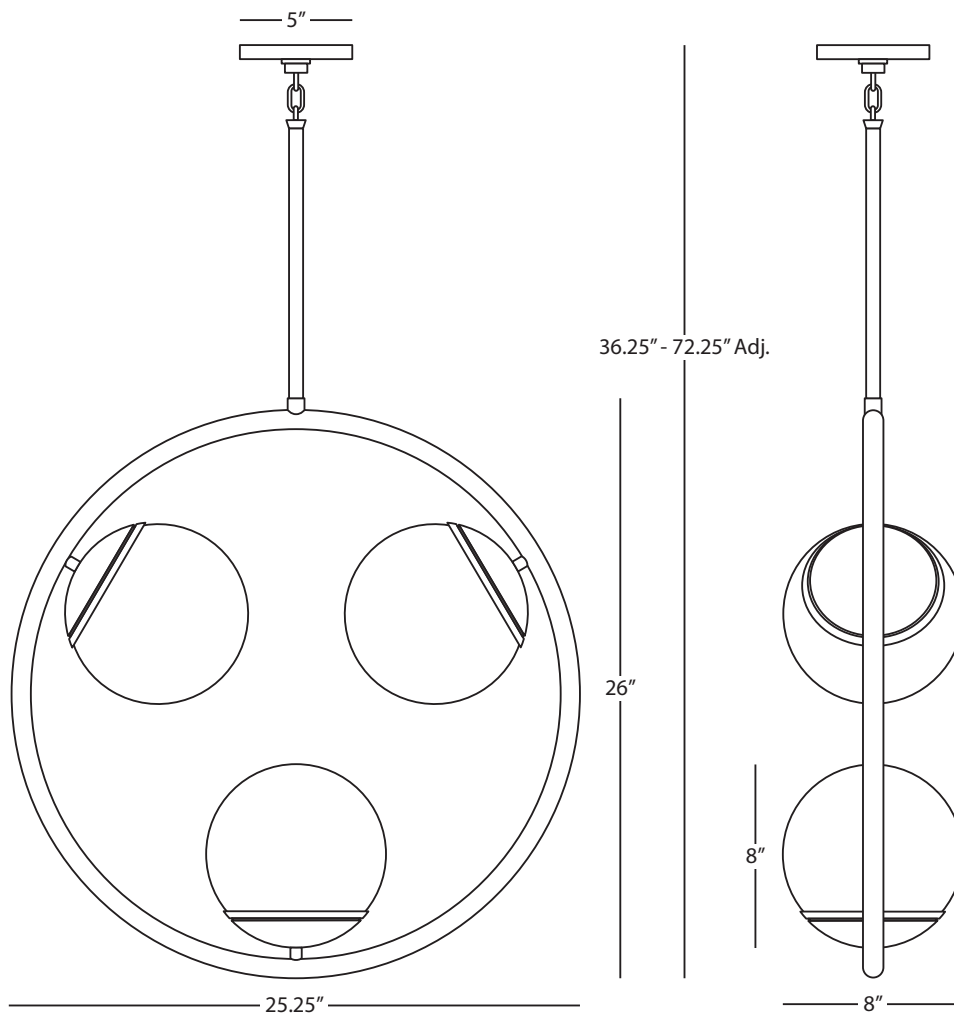

JONATHAN ADLER JUPITER

## 3542

### Chandelier

3 - 60W Max.  
Bulb Type: A  
Direct Wire  
Modern Brass Finish  
Cased White Glass Globe Shades  
Susp. Hardware: 1 pc. 5/8" x 6" & 3 pcs.  
5/8" x 12" Extensions

#### FINISH OPTION:

**S3542** Polished Nickel

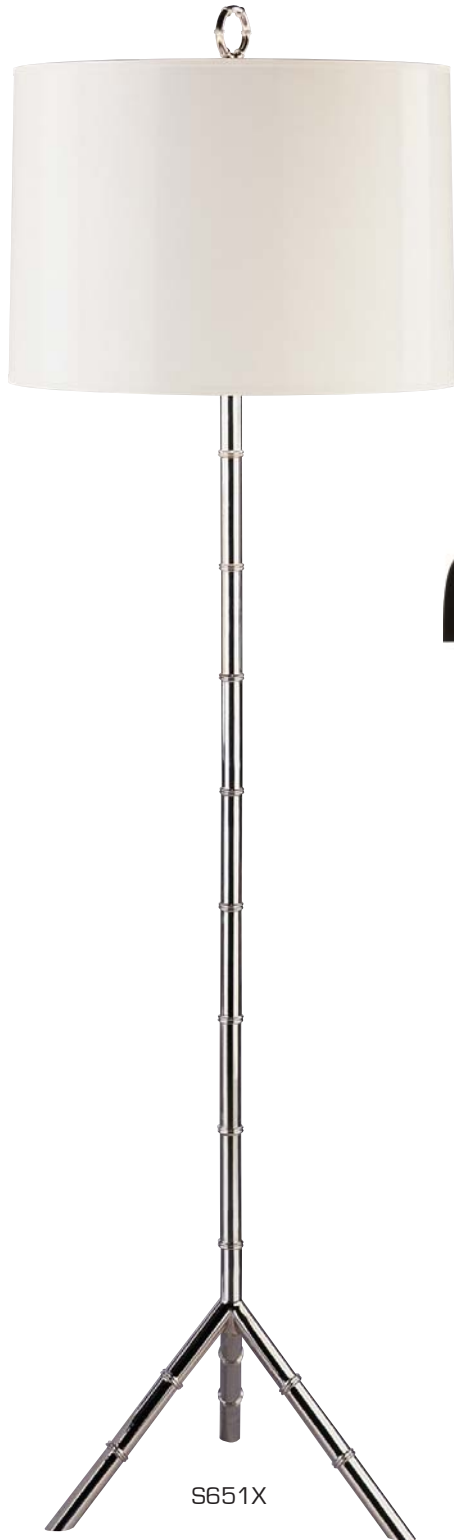

S651X



Z647

# Jonathan Adler Meurice

JONATHAN ADLER MEURICE

## Z647

### Adjustable Task Floor Lamp

1 - 60W Max.  
 Bulb Type: A  
 Switch: Full Range Foot Dimmer  
 Deep Patina Bronze Finish  
 Metal Shade

FINISH OPTIONS:

**647** Modern Brass  
**S647** Polished Nickel

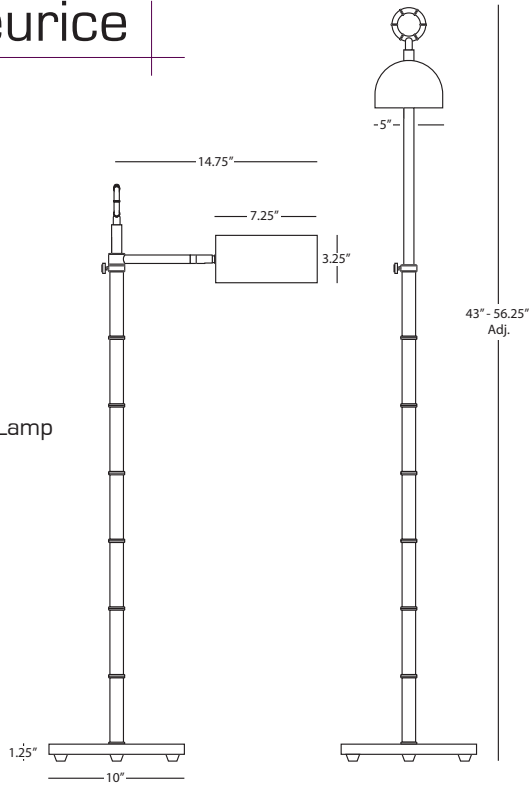

JONATHAN ADLER MEURICE

## S651X

### Club Floor Lamp

1 - 150W Max.  
 Bulb Type: A  
 Switch: Full Range Dimmer  
 Polished Nickel Finish  
 White Parchment Shade w/  
 Matte Silver Lining

FINISH/SHADE OPTIONS:

**651** Modern Brass  
 Off-White Linen Shade  
 w/ Rolled Edge Hem  
**651B** Modern Brass  
 Black Parchment Shade  
 w/ Matte Gold Lining  
**S651** Polished Nickel  
 Off-White Linen Shade  
 w/ Rolled Edge Hem

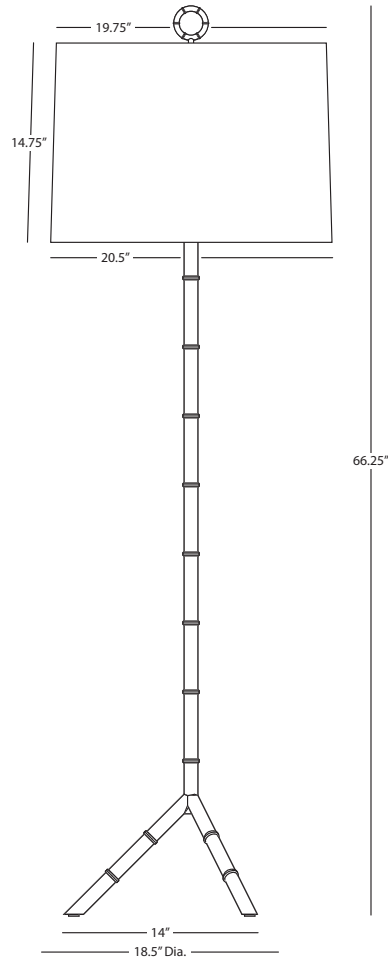



Z657



S654



764

# Jonathan Adler Meurice

JONATHAN ADLER MEURICE

## Z657

### Large Pendant

3 - 100W Max.  
 Bulb Type: A  
 Direct Wire Only  
 Deep Patina Bronze Finish  
 Off-White Linen Shade w/ Rolled Edge Hem  
 24" Acrylic Diffuser  
 Susp. Hardware: 3 Ft. Chain

FINISH OPTIONS:

**657** Modern Brass  
**S657** Polished Nickel

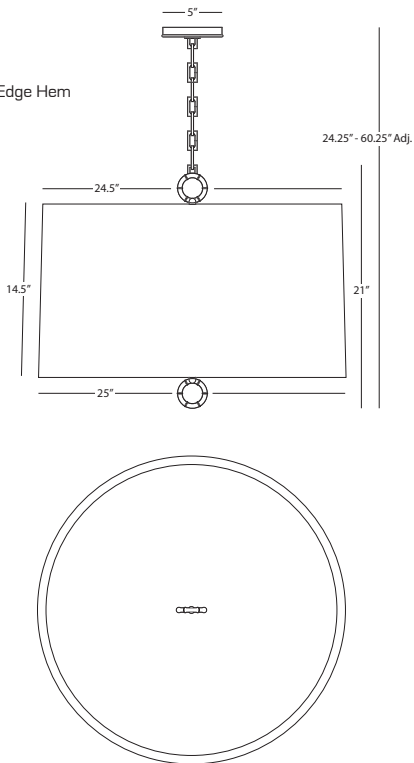

JONATHAN ADLER MEURICE

## S654

### 30-Light Chandelier

30 - 25W Max.  
 Bulb Type: G16.5 Candelabra  
 Direct Wire Only  
 Polished Nickel Finish  
 Susp. Hardware: 3 pcs. 5/8" x 12"  
 & 1 pc. 5/8" x 6" Extensions

FINISH OPTIONS:

**654** Modern Brass  
**Z654** Deep Patina Bronze

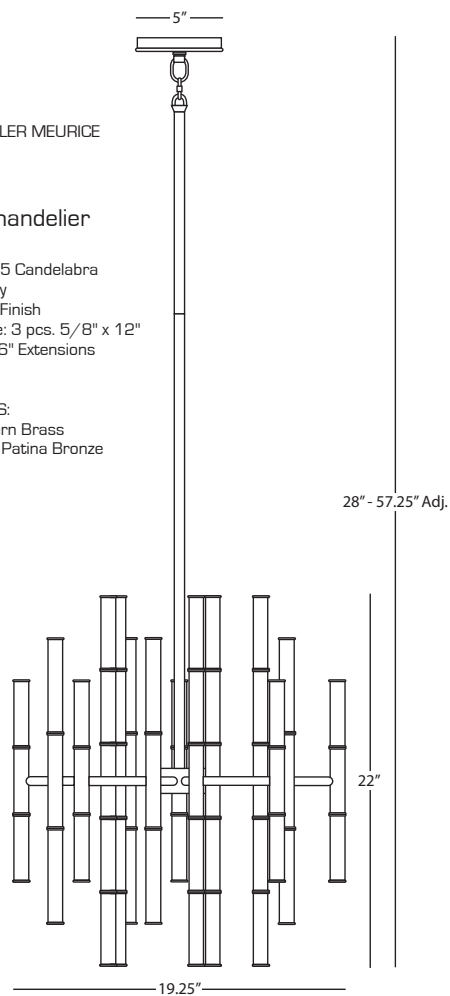

JONATHAN ADLER MEURICE

## 764

### Half Round Wall Sconce

2 - 40W Max.  
 Bulb Type: B, Medium Base  
 Direct Wire Only  
 Modern Brass Finish  
 ADA Compliant

FINISH OPTIONS:

**S764** Polished Nickel  
**Z764** Deep Patina Bronze

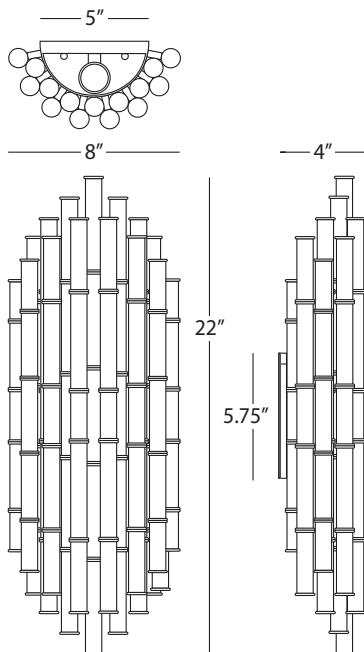



686



Z686



S687



# Jonathan Adler Meurice

JONATHAN ADLER MEURICE

## 686 5-Arm Sconce

10 - 25W Max.  
Bulb Type: G16.5 Candelabra  
24" Cord Cover/Direct Wire  
Modern Brass Finish

FINISH OPTIONS:

- S686** Polished Nickel
- Z686** Deep Patina Bronze

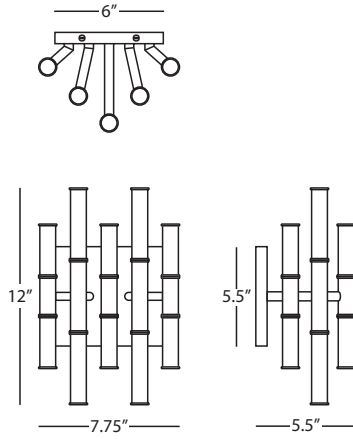

JONATHAN ADLER MEURICE

## S687 Rectangular Chandelier

42 - 25W Max.  
Bulb Type: G16.5 Candelabra  
Direct Wire Only  
Polished Nickel Finish  
Susp. Hardware: 6 pcs. 5/8" x 12" &  
2 pcs. 5/8" x 6" Extensions

FINISH OPTIONS:

- 687** Modern Brass
- Z687** Deep Patina Bronze

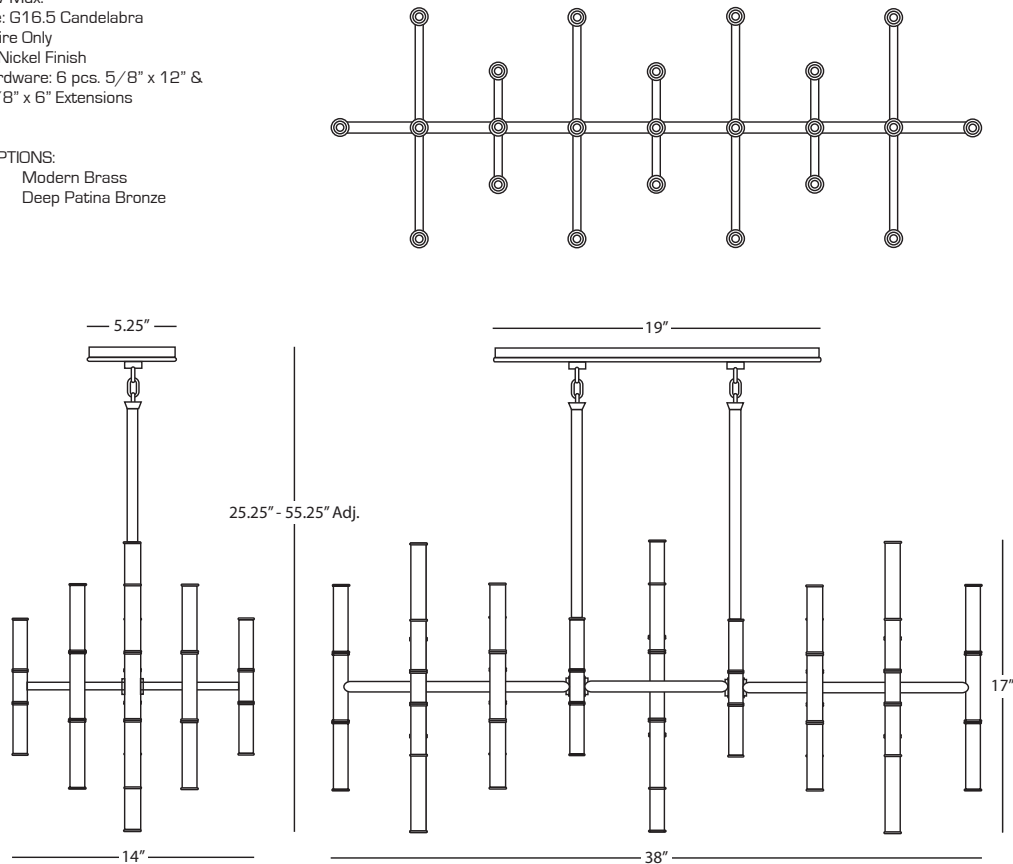



S689



763



Z761



S760

# Jonathan Adler Meurice

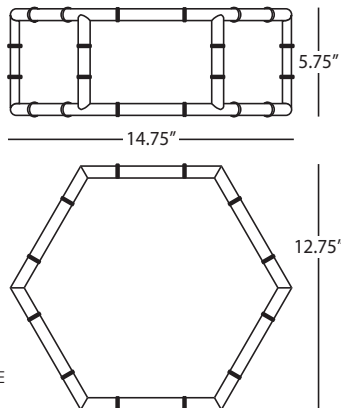

JONATHAN ADLER MEURICE

## 763 Hexagonal Flush Mount

3 - 40W Max.  
Bulb Type: A  
Direct Wire  
Modern Brass Finish  
Frosted White Glass Shade

FINISH OPTIONS:  
**S763** Polished Nickel  
**Z763** Deep Patina Bronze

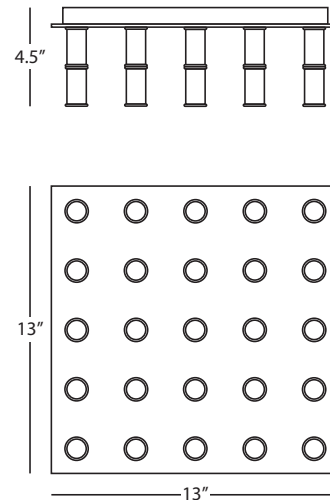

JONATHAN ADLER MEURICE

## 689 25-Light Flush Mount

25 - 15W Max.  
Bulb Type: G16.5, Candelabra  
Direct Wire Only  
Modern Brass Finish

FINISH OPTIONS:  
**S689** Polished Nickel  
**Z689** Deep Patina Bronze



JONATHAN ADLER MEURICE

## Z761 Medium Wall Sconce

3 - 60W Max.  
Bulb Type: B11 Torpedo  
Direct Wire Only  
Deep Patina Bronze Finish  
Frosted White Glass Shade  
ADA Compliant

FINISH OPTION:  
**S761** Polished Nickel

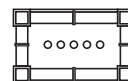
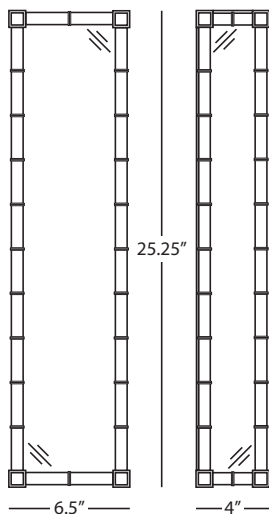

JONATHAN ADLER MEURICE

## S760 Small Wall Sconce

2 - 60W Max.  
Bulb Type: B11 Torpedo  
Direct Wire Only  
Polished Nickel Finish  
Frosted White Glass Shade  
ADA Compliant

FINISH OPTION:  
**Z760** Deep Patina Bronze

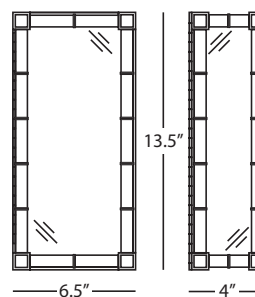

# Jonathan Adler Milano



# Jonathan Adler Milano

---

Click photo above to watch Jonathan Adler Milano Video

One of our favorite collections by designer Jonathan Adler, Milano is architecturally dynamic but also graceful, light, and airy. We're introducing an over-sized linear chandelier to the Milano collection this market, measuring 60" in length. This piece makes a grand and distinguishing statement.

---



S905



803



WB754

# Jonathan Adler Milano

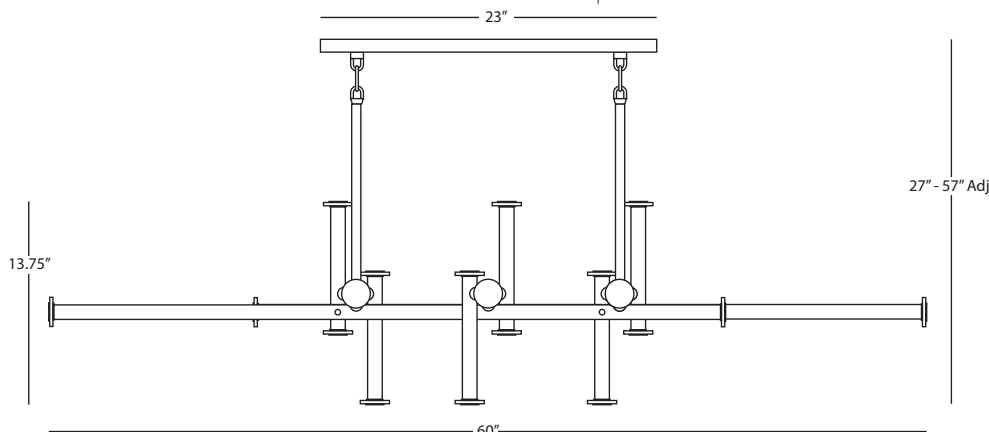

JONATHAN ADLER MILANO

## S905 Linear Chandelier

22 - 40W Max.  
Bulb Type: G, Candelabra  
Direct Wire  
Polished Nickel Finish w/  
Lucite Accents  
Susp. Hardware: 6 pcs. 5/8" x 12" &  
2 pcs. 5/8" x 6" Extensions

FINISH OPTIONS:  
**905** Polished Brass  
**WB905** Warm Brass  
**Z905** Deep Patina Bronze

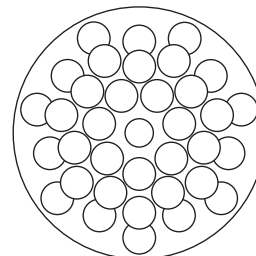
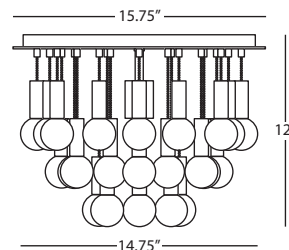
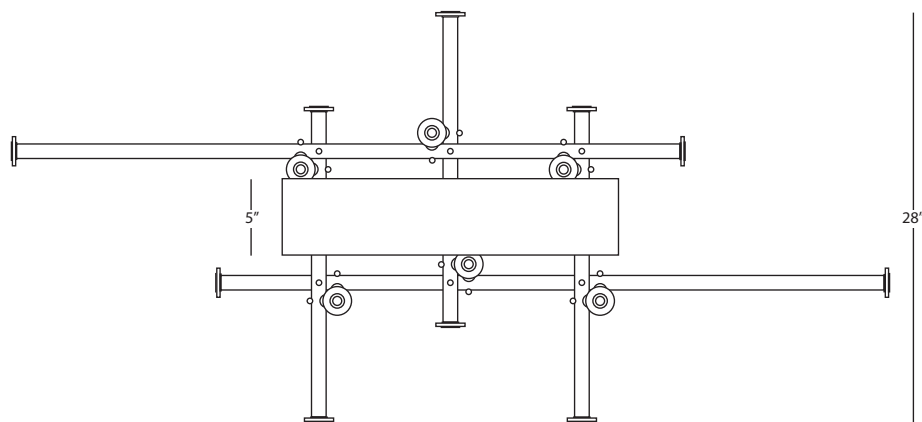

JONATHAN ADLER MILANO

## WB754 Flush Mount

1 - 60W Max.  
Bulb Type: A  
Direct Wire  
Warm Brass Finish  
Crystal Accents

Ships with Silver Tip Bulb  
[BUL01 See page 272]

FINISH OPTIONS:  
**754** Polished Brass  
**S754** Polished Nickel  
**Z754** Deep Patina Bronze

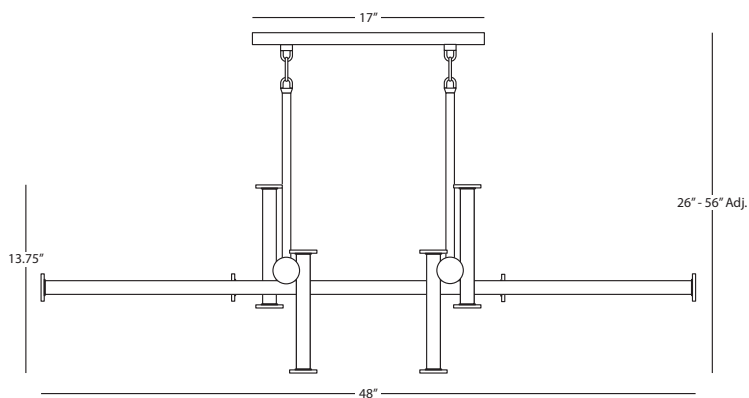

JONATHAN ADLER MILANO

## 803 Linear Chandelier

16 - 40W Max.  
Bulb Type: G, Candelabra  
Direct Wire  
Polished Brass Finish w/  
Lucite Accents  
Susp. Hardware: 6 pcs. 5/8" x 12" &  
2 pcs. 5/8" x 6" Extensions

FINISH OPTIONS:  
**S803** Polished Nickel  
**WB803** Warm Brass  
**Z803** Deep Patina Bronze

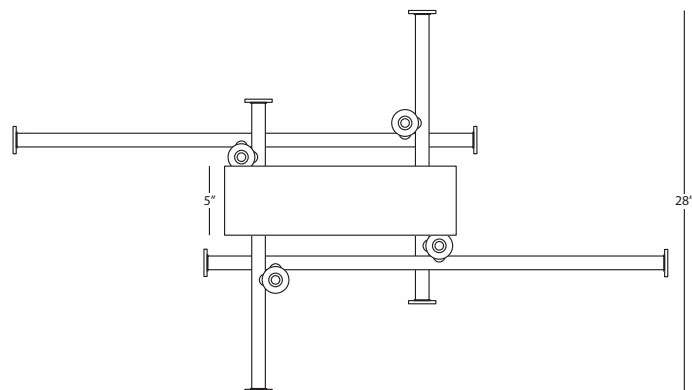



WB399



902



Z901



# Jonathan Adler Milano

JONATHAN ADLER MILANO

## WB399

### Component Chandelier

30 - 40W Max.  
 Bulb Type: G, Candelabra  
 Direct Wire  
 Warm Brass Finish  
 Susp. Hardware: 6 pcs. 5/8" x 12"  
 & 2 pcs. 5/8" x 6" Extensions

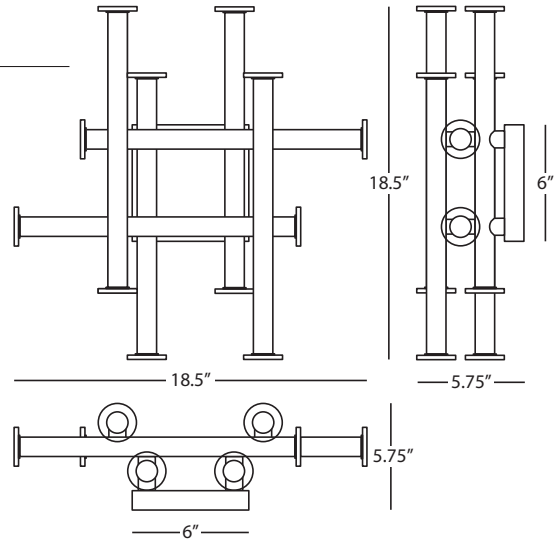
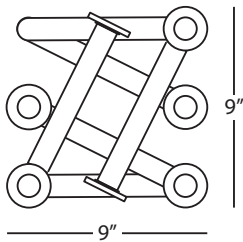
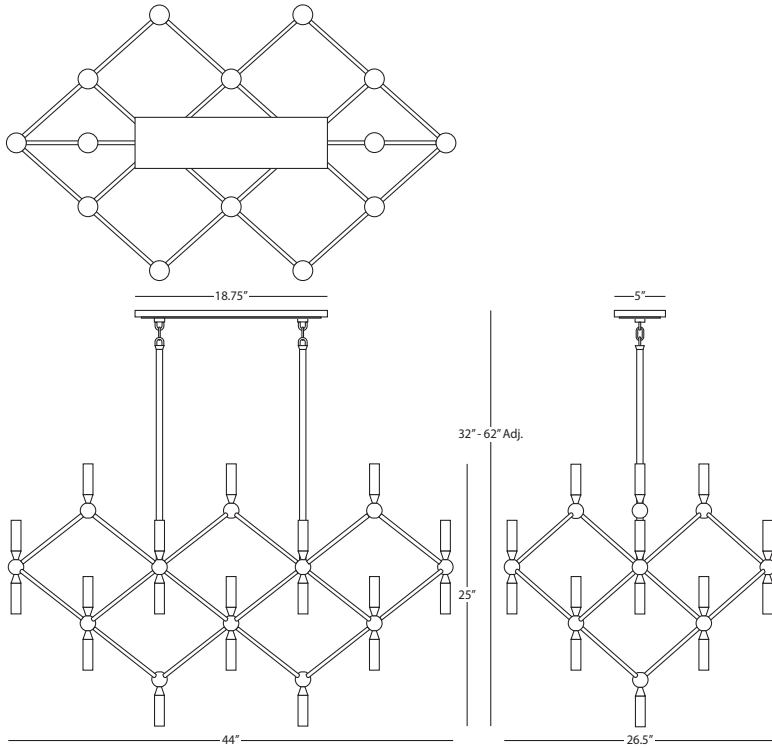

JONATHAN ADLER MILANO

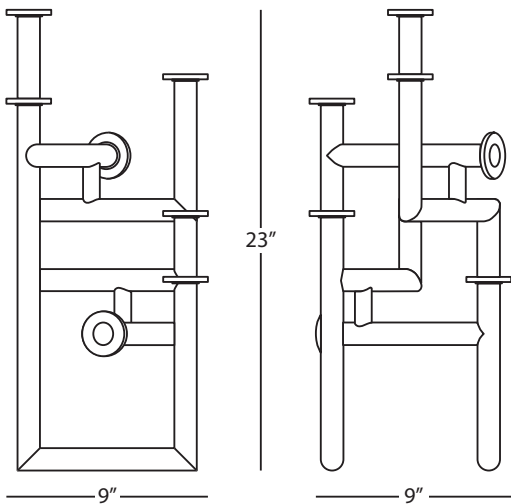

JONATHAN ADLER MILANO

## 902

### Modernist Table Lamp

7 - 40W Max.  
 Bulb Type: G, Candelabra  
 Switch: Full Range Dimmer Line Switch  
 Polished Brass Finish w/  
 Lucite Accents

FINISH OPTIONS:  
**S902** Polished Nickel  
**WB902** Warm Brass  
**Z902** Deep Patina Bronze

## S901

### Linear Wall Sconce

12 - 25W Max.  
 Bulb Type: G, Candelabra  
 Direct Wire Only  
 Polished Nickel Finish w/  
 Lucite Accents

FINISH OPTIONS:  
**901** Polished Brass  
**WB901** Warm Brass  
**Z901** Deep Patina Bronze



WB804



S906



903

# Jonathan Adler Milano

JONATHAN ADLER MILANO

## S906 Kinetic Chandelier

8 - 60W Max.  
Bulb Type: G, Medium Base  
Direct Wire  
Polished Nickel Finish  
Susp. Hardware: 1 pc. 5/8" x 6" & 3 pcs.  
5/8" x 12" Extensions

Photographed with Silver Tip Bulbs  
SOLD SEPARATELY  
(BULS1 [x 8] See Page 225)

FINISH OPTIONS:  
**906** Polished Brass  
**WB906** Warm Brass  
**Z906** Deep Patina Bronze

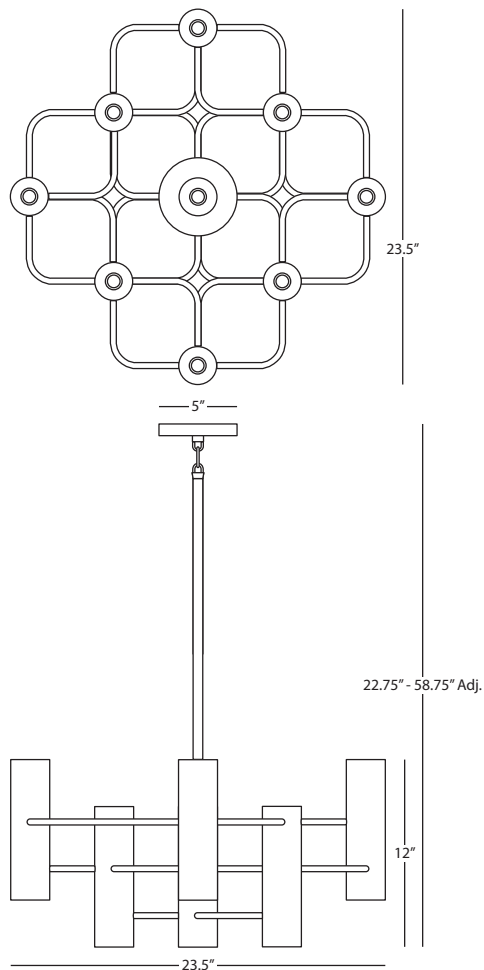
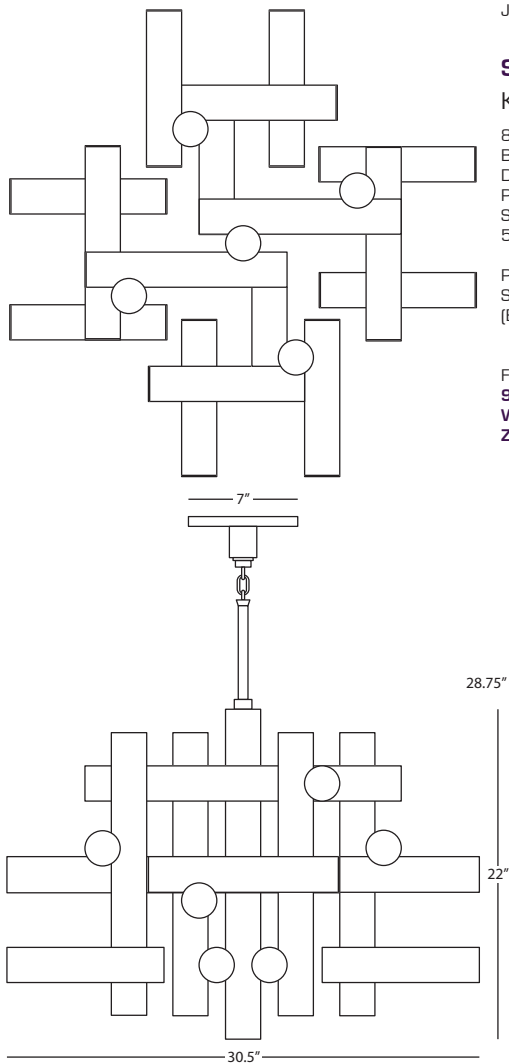

JONATHAN ADLER MILANO

## 903 Square Pendant

17 - 40W Max.  
Bulb Type: G, Medium Base  
Direct Wire  
Polished Brass Finish  
Susp. Hardware: 1 pc. 5/8" x 6" & 3 pcs.  
5/8" x 12" Extensions

FINISH OPTIONS:  
**S903** Polished Nickel  
**WB903** Warm Brass  
**Z903** Deep Patina Bronze

JONATHAN ADLER MILANO

## WB804 Square Flush Mount

9 - 60W Max.  
Bulb Type: G, Candelabra  
Direct Wire  
Warm Brass Finish

FINISH OPTIONS:  
**804** Polished Brass  
**S804** Polished Nickel  
**Z804** Deep Patina Bronze

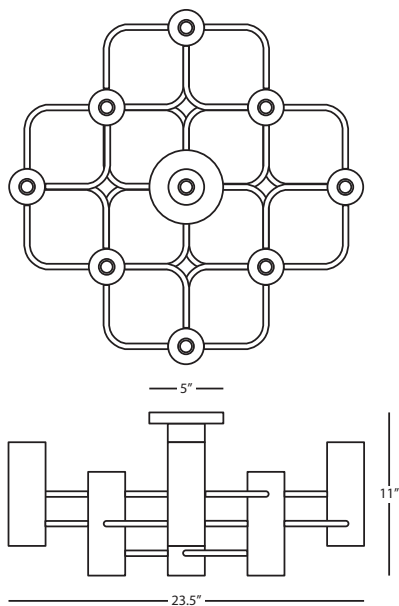

# Jonathan Adler Monaco

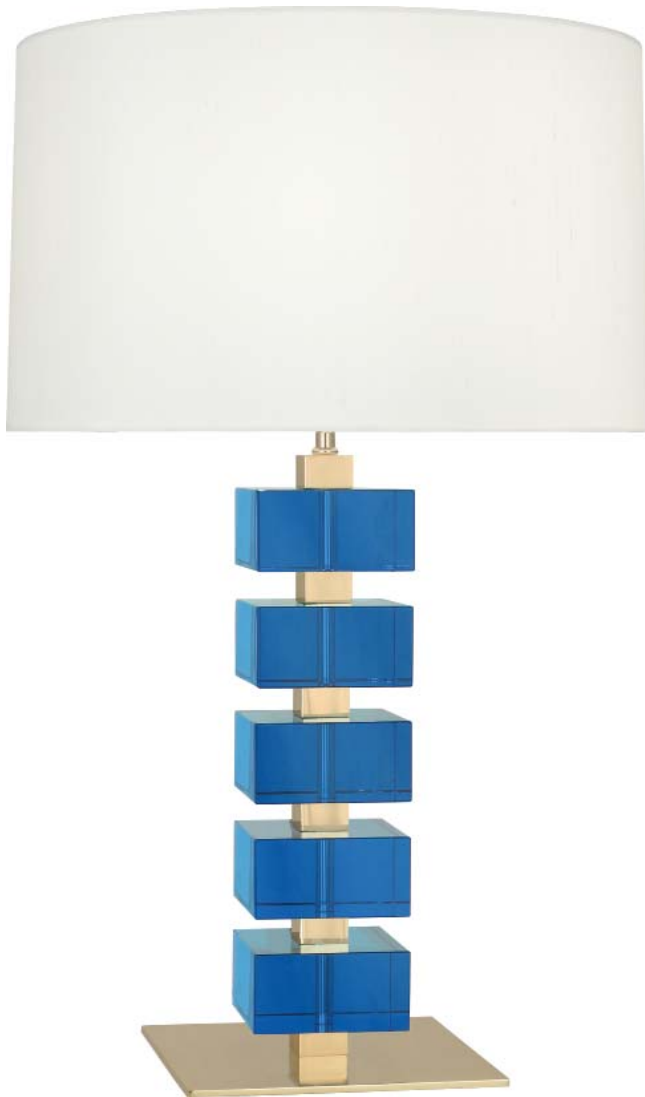

176X



175

# Jonathan Adler Monaco

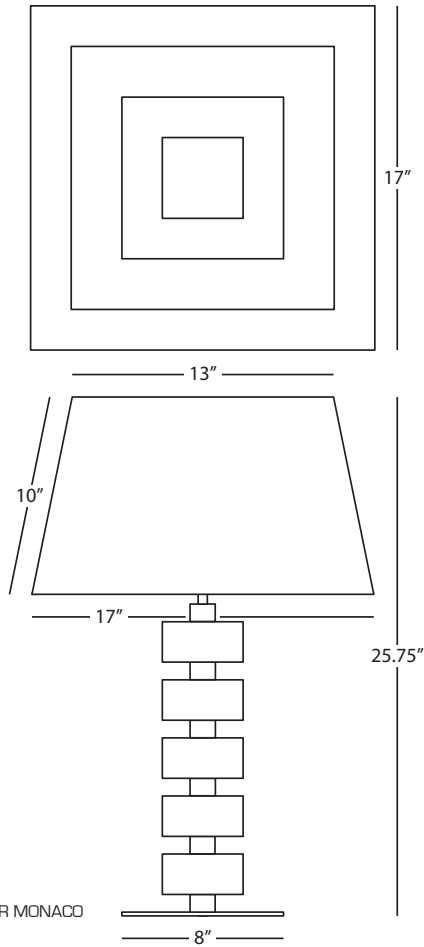

JONATHAN ADLER MONACO

## 175

### Table Lamp

1 - 150W Max.  
 Bulb Type: A  
 Switch: Full Range Dimmer  
 Polished Nickel Finish  
 Clear Crystal Blocks  
 Square, White Silk Shade

#### FINISH OPTIONS:

**176** Lacquered, Natural Brass  
 Turquoise Crystal  
 Square, Off-White Silk Shade

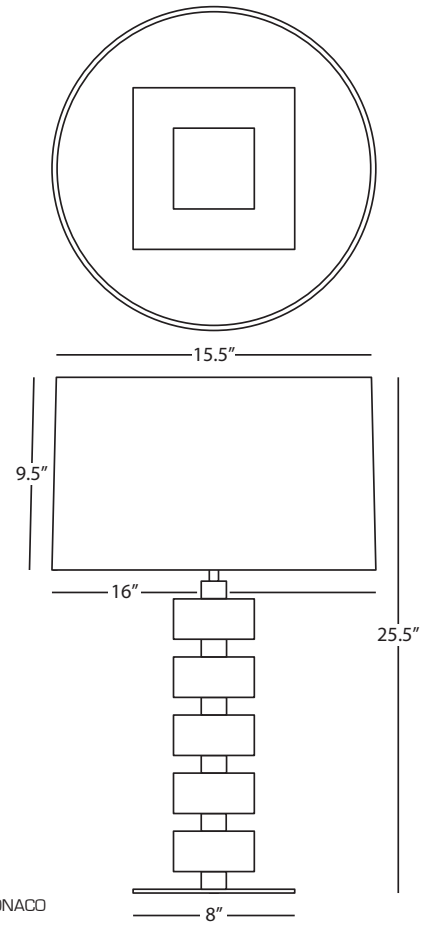

JONATHAN ADLER MONACO

## 176X

### Table Lamp

1 - 150W Max.  
 Bulb Type: A  
 Switch: Full Range Dimmer  
 Lacquered, Natural Brass  
 Turquoise Crystal Blocks  
 Round, Off-White Silk Shade w/  
 Rolled Edge Hem

#### FINISH OPTIONS:

**175X** Polished Nickel  
 Clear Crystal  
 Round, White Silk Shade w/  
 Rolled Edge Hem

# Jonathan Adler Mykonos



157



S157

# Jonathan Alder Mykonos

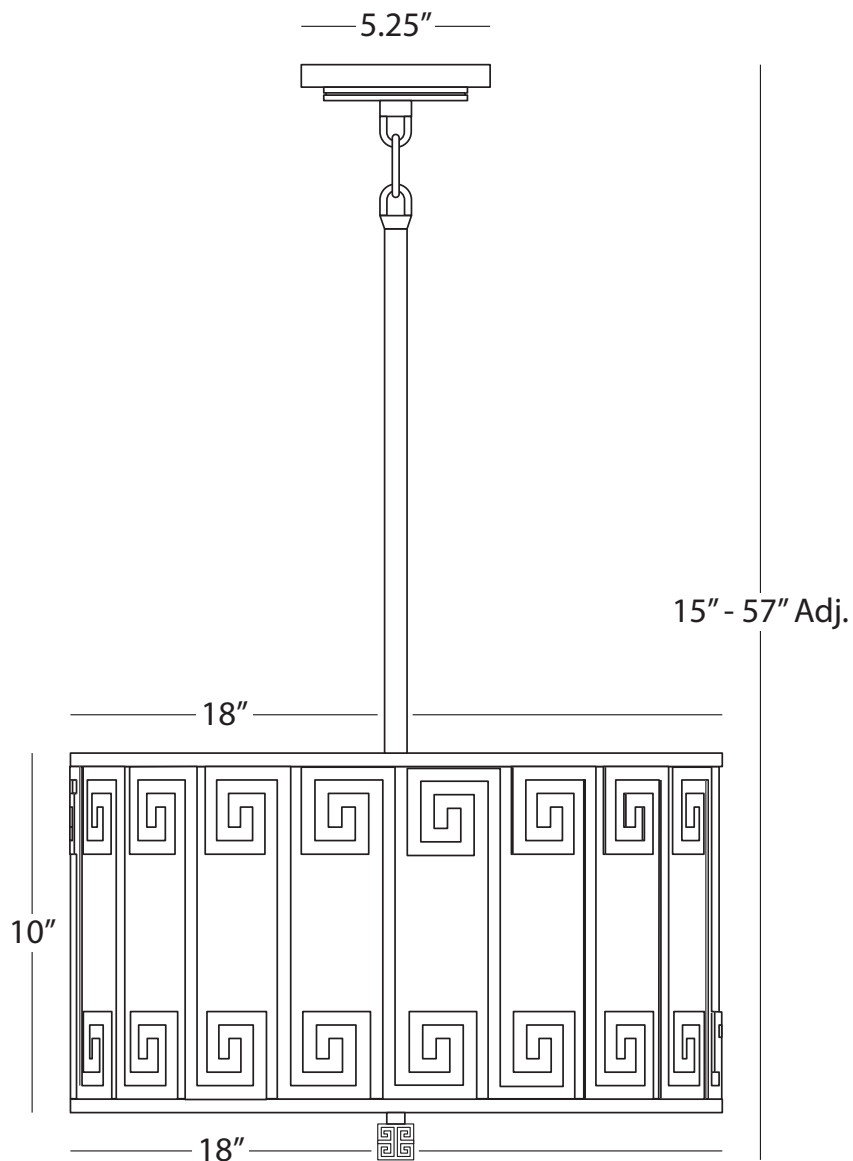

JONATHAN ADLER MYKONOS

## 157

### Pendant

2 - 100W Max.  
Bulb Type: A  
Direct Wire  
Modern Brass Finish  
White Cotton Fabric Shade w/  
White Acrylic Polished Diffuser  
Susp. Hardware: 1 pc. 5/8" x 6" & 3 pcs.  
5/8" x 12" Extensions

#### FINISH OPTION:

**S157** Polished Nickel



639



Z639



S660



# Jonathan Adler Parker

JONATHAN ADLER PARKER

## 639

### Adjustable Wall Sconce

1 - 60W Max.  
 Bulb Type: G16.5 Candelabra  
 24" Cord Cover/Direct Wire  
 Antique Brass Finish  
 Frosted White Cased Glass Shade w/  
 Perforated Metal Detail

FINISH OPTIONS:

**S639** Polished Nickel  
**Z639** Deep Patina Bronze

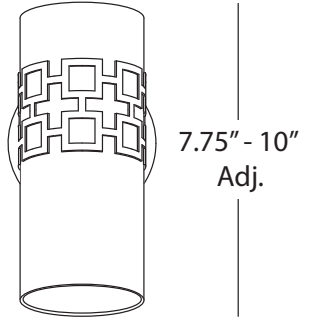
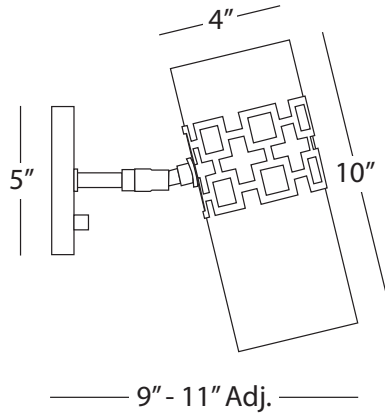

JONATHAN ADLER PARKER

## S660

### Table Torchiere

1 - 60W Max.  
 Bulb Type: A  
 Switch: Full Range Dimmer Line Switch  
 Polished Nickel Finish  
 White Carrara Marble Base  
 Frosted White Cased Glass Shade  
 Perforated Metal Outer Shade

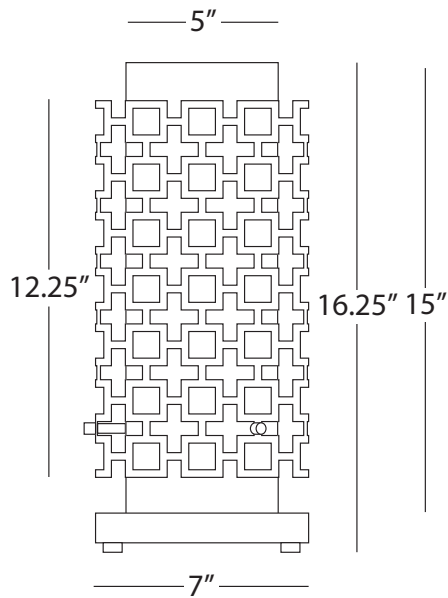
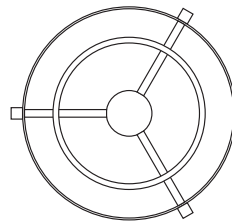



S663



S664



Z662



667

# Jonathan Adler Parker

JONATHAN ADLER PARKER

## S664 Flush Mount

3 - 75W Max.  
Bulb Type: A  
Direct Wire Only  
Polished Nickel Finish  
Frosted White Cased Glass Shade  
Perforated Metal Outer Shade

FINISH OPTIONS:

**664** Antique Brass  
**Z664** Deep Patina Bronze

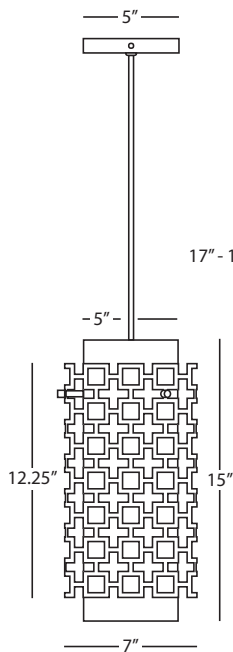
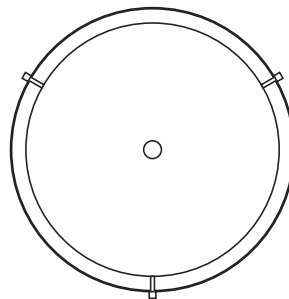
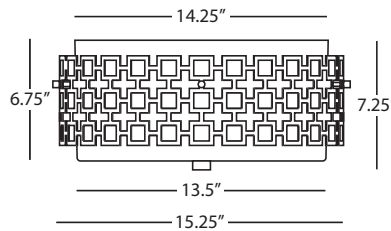

JONATHAN ADLER PARKER

## S663 Pendant

1 - 60W Max.  
Bulb Type: A  
Direct Wire Only  
Polished Nickel Finish  
Frosted White Cased Glass Shade  
Perforated Metal Outer Shade  
Susp. Hardware: 12 Ft. Cord

FINISH OPTION:

**663** Antique Brass

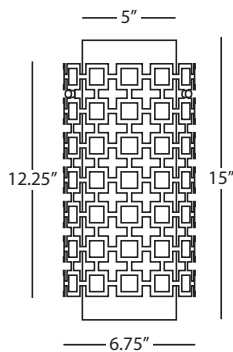

JONATHAN ADLER PARKER

## Z662 Half Round Wall Sconce

1 - 60W Max.  
Bulb Type: B, Candelabra  
Direct Wire Only  
Deep Patina Bronze Finish  
Frosted White Cased Glass Shade  
Perforated Metal Outer Shade  
ADA Compliant

FINISH OPTIONS:

**662** Antique Brass  
**S662** Polished Nickel

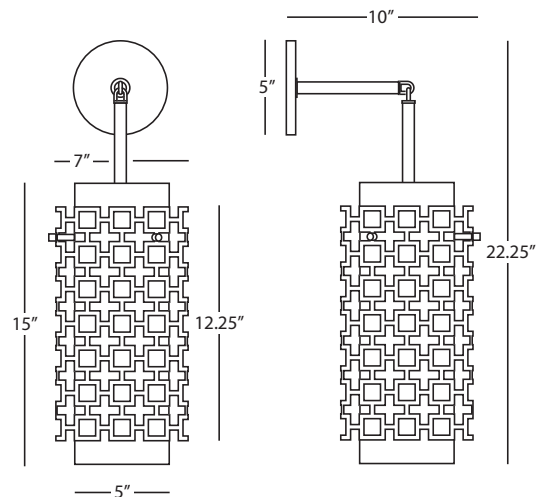

JONATHAN ADLER PARKER

## 667 Pendant Sconce

1 - 60W Max.  
Bulb Type: A  
Direct Wire Only  
Antique Brass Finish  
Frosted White Cased Glass Shade  
Perforated Metal Outer Shade

FINISH OPTION:

**S667** Polished Nickel

# Jonathan Adler Rio



788



Z779



S792



792



777



S777



Z777

# Jonathan Adler Rio

JONATHAN ADLER RIO

## 777 Wall Sconce

2 - 13W Max.  
Bulb Type: GU24 CFL  
Direct Wire Only  
Antique Brass Finish  
White Glass Shades  
UL Rated for Wet Locations

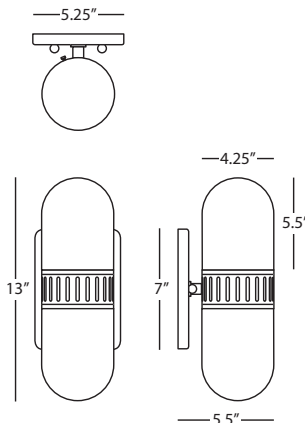

FINISH OPTIONS:  
**S777** Polished Nickel  
**Z777** Deep Patina Bronze

JONATHAN ADLER RIO

## Z779 Pendant

1 - 13W Max.  
Bulb Type: GU24 CFL  
Direct Wire  
Deep Patina Bronze Finish  
White Glass Shade  
Susp. Hardware: 12 Ft. Black Cord  
UL Rated for Damp Locations

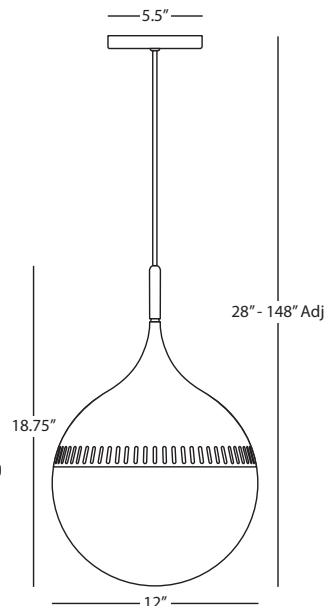

FINISH OPTIONS:  
**779** Antique Brass  
**S779** Polished Nickel

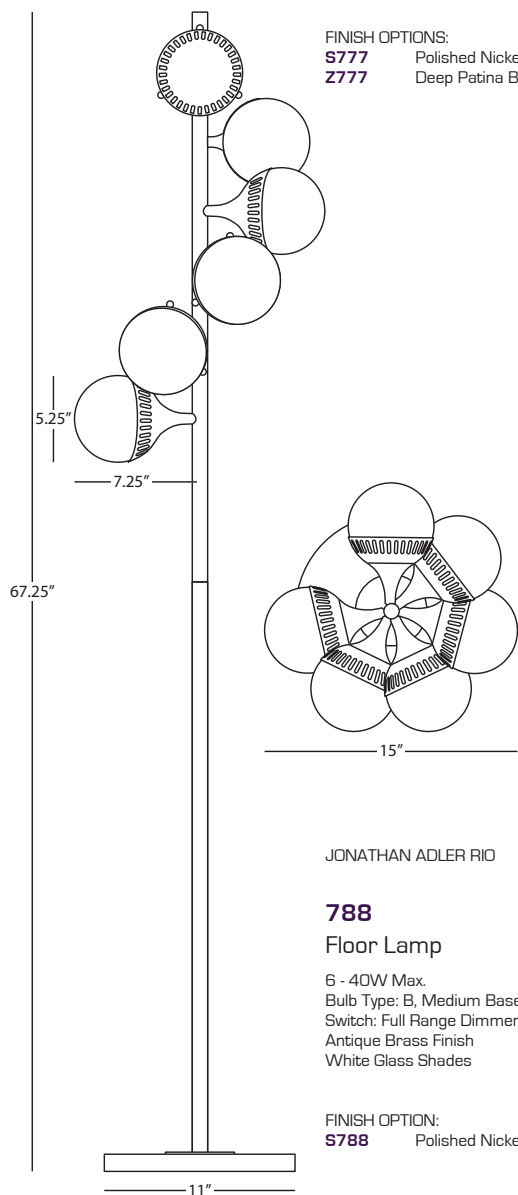

JONATHAN ADLER RIO

## 788 Floor Lamp

6 - 40W Max.  
Bulb Type: B, Medium Base  
Switch: Full Range Dimmer Line Switch  
Antique Brass Finish  
White Glass Shades

FINISH OPTION:  
**S788** Polished Nickel

JONATHAN ADLER RIO

## 792 Small Pendant

1 - 40W Max.  
Bulb Type: A  
Direct Wire  
Antique Brass Finish  
White Glass Shade  
Susp. Hardware: 12 Ft. Black Fabric  
Wrapped Cord

FINISH OPTIONS:  
**S792** Polished Nickel  
**Z792** Deep Patina Bronze

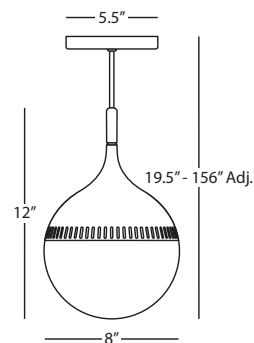



791

# Jonathan Adler Rio

JONATHAN ADLER RIO

**791**

**Multi-Globe Chandelier**

3 - 40W Max. & 2 - 60W Max.  
Bulb Type: A  
Direct Wire  
Antique Brass Finish  
White Glass Shades  
Susp. Hardware: 5 pcs. 11 Ft. Black  
Fabric Wrapped Cord

NOTE: Globes can be arranged in any configuration the customer desires. The shortest drop possible is 30". The greatest drop possible is 136".

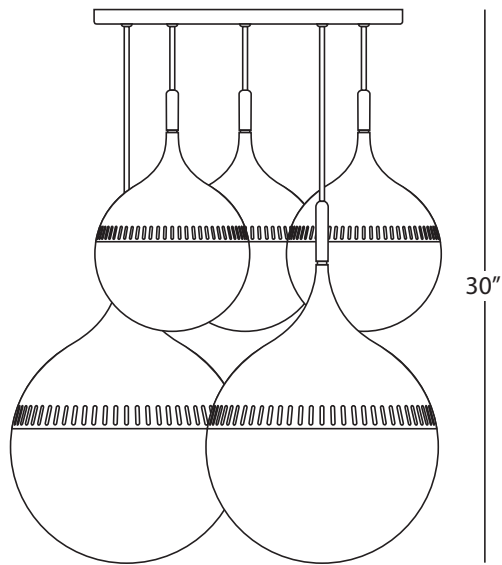

MINIMUM DROP GLOBE CONFIGURATION

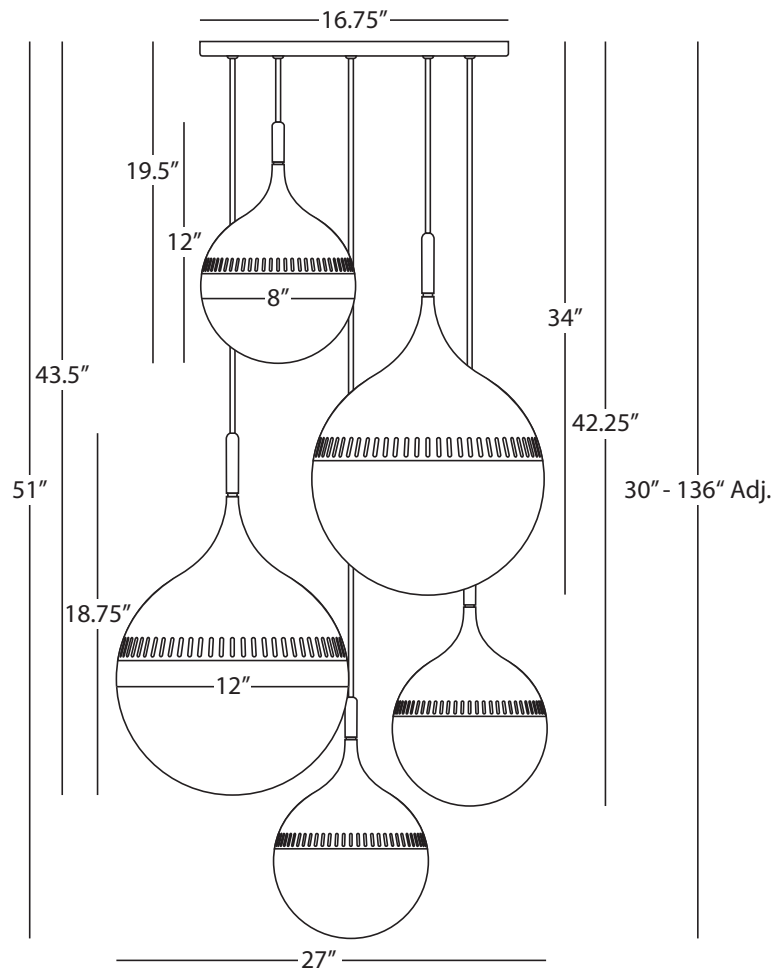

AS PHOTOGRAPHED

# Jonathan Adler Saturn



R911



L910



R910G



L911B



# Jonathan Adler Saturn

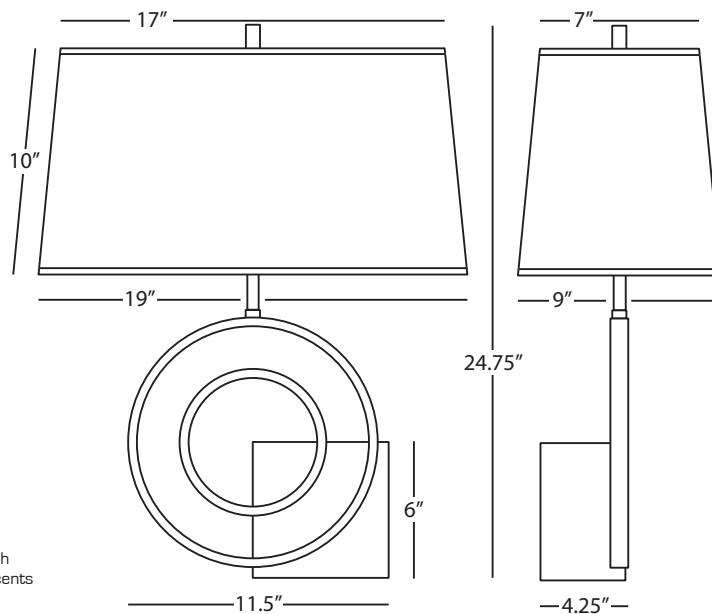

JONATHAN ADLER SATURN

## L910

### Left Facing Table Lamp

2 - 100W Max.  
 Bulb Type: A  
 Switch: Full Range Dimmer Line Switch  
 White Marble w/ Polished Nickel Accents  
 Rectangular Oyster Linen Shade

#### FINISH/SHADE OPTIONS:

- L910G** White Marble/Polished Nickel w/ Smoke Gray Shade
- L911** Black Marble/Antique Brass w/ Oyster Linen Shade
- L911B** Black Marble/Antique Brass w/ Black Parchment Shade w/ White Lining

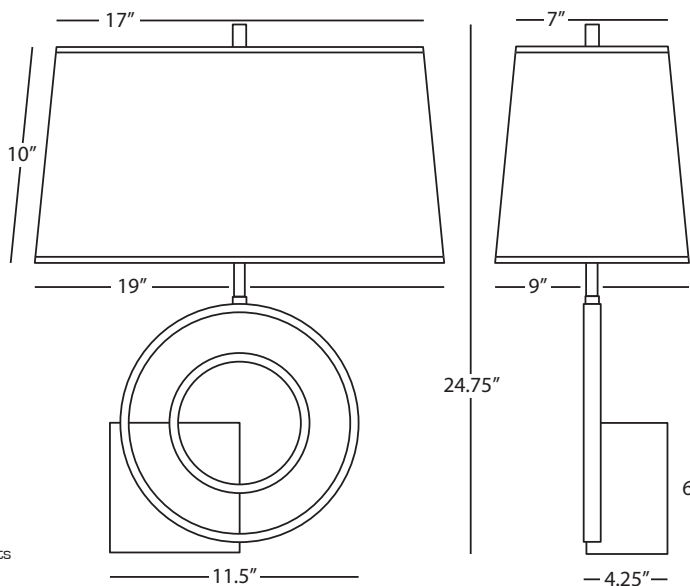

JONATHAN ADLER SATURN

## R910G

### Right Facing Table Lamp

2 - 100W Max.  
 Bulb Type: A  
 Switch: Full Range Dimmer Line Switch  
 White Marble w/ Polished Nickel Accents  
 Rectangular Smoke Gray Fabric Shade

#### FINISH/SHADE OPTIONS:

- R910** White Marble/Polished Nickel w/ Oyster Linen Shade
- R911** Black Marble/Antique Brass w/ Oyster Linen Shade
- R911B** Black Marble/Antique Brass w/ Black Parchment Shade w/ White Lining

# Jonathan Adler Sputnik



S710



711



714

# Jonathan Adler Sputnik

JONATHAN ADLER SPUTNIK

## S710

### Chandelier

24 - 40W Max.  
 Bulb Type: G16.5 Candelabra  
 Direct Wire  
 Polished Nickel Finish w/  
 Crystal Accents  
 Susp. Hardware: 3 pcs. 1/2" x  
 12" & 1 pc. 1/2" x 6" Extensions

FINISH OPTION:

**710** Antique Brass

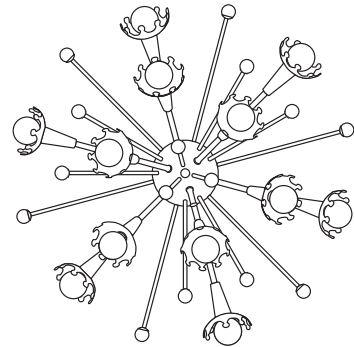
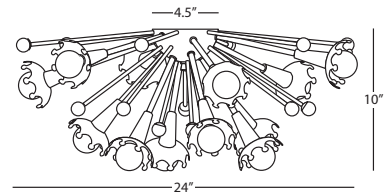
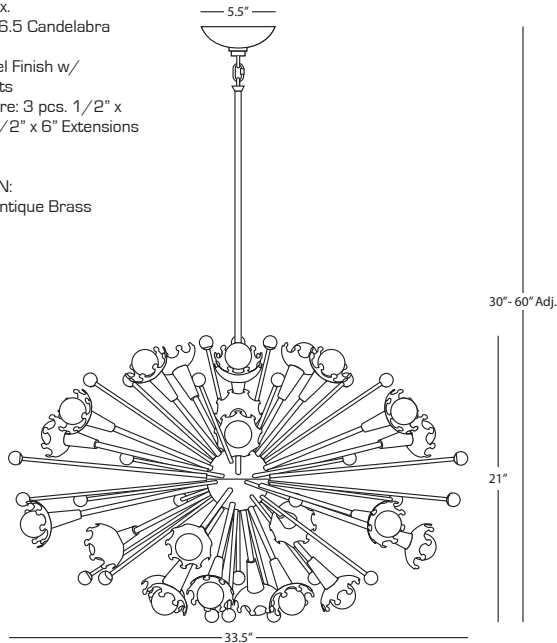

JONATHAN ADLER SPUTNIK

## 711

### Flush Mount/Scence

12 - 40W Max.  
 Bulb Type: G16.5 Candelabra  
 Direct Wire Only  
 Antique Brass Finish w/  
 Crystal Accents

FINISH OPTION:

**S711** Polished Nickel

JONATHAN ADLER SPUTNIK

## 714

### Large Chandelier

24 - 40W Max.  
 Bulb Type: G16.5 Candelabra  
 Direct Wire  
 Antique Brass Finish w/  
 Clear Crystal Accents  
 Susp. Hardware: 3 pcs. 5/8" x 12"  
 & 1 pc. 5/8" x 6" Extensions

FINISH OPTION:

**S714** Polished Nickel

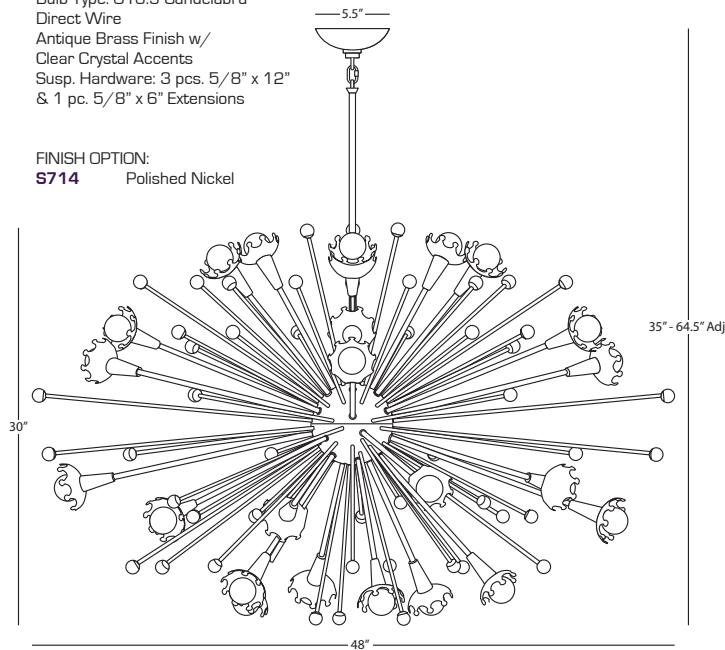

# Jonathan Adler Totem



237G



237



238



238B

# Jonathan Adler Totem

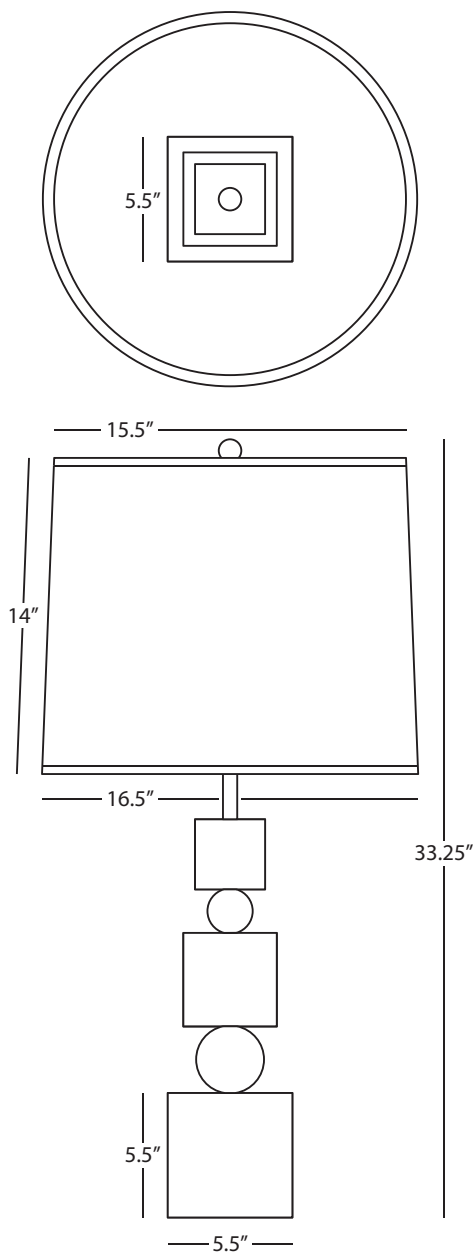

JONATHAN ADLER TOTEM

**237**

Table Lamp

1 - 150W Max.

Bulb Type: A

Switch: Full Range Dimmer

White Marble w/ Modern Brass Accents

Oyster Linen Fabric Shade

FINISH/SHADE OPTIONS:

**237G** White Marble/Smoke Gray Fabric

**238** Black Marble/Oyster Linen

**238B** Black Marble/Black Opaque Parchment w/ White Lining



PN671



672



WH672



WH770



AW771

# Jonathan Adler Ventana

JONATHAN ADLER VENTANA

## 672

### Wall Sconce

1 - 60W Max.  
 Bulb Type: G16.5 Candelabra  
 Switch: Hi-Lo Dimming  
 24" Cord Cover/Direct Wire  
 Ebony Finished Wood w/  
 Antique Brass Accents  
 Oval, Natural Linen Shade w/ Rolled Edge Hem

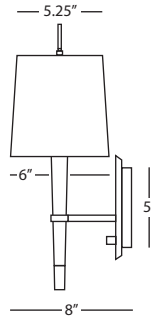
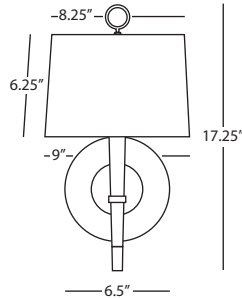

FINISH/SHADE OPTIONS:

- AW672** White Wood w/ Polished Nickel Accents  
Ascot White
- PN672** Ebony Wood w/ Polished Nickel Accents  
Natural Linen w/ Rolled Edge Hem
- WH672** White Wood w/ Polished Nickel Accents  
Dark Gray Cotton w/ Rolled Edge Hem

JONATHAN ADLER VENTANA

## AW771

### Double Sconce

2 - 60W Max.  
 Bulb Type: B, Candelabra  
 Switch: Hi-Lo Dimming  
 24" Cord Cover/Direct Wire  
 White Finished Wood w/ Polished Nickel Accents  
 Ascot White Shades

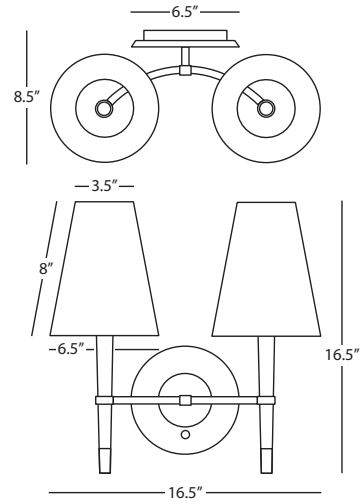

FINISH/SHADE OPTIONS:

- 771** Ebony Wood w/ Antique Brass Accents  
Natural Linen w/ Rolled Edge Hem
- PN771** Ebony Wood w/ Polished Nickel Accents  
Natural Linen w/ Rolled Edge Hem
- WH771** White Wood w/ Polished Nickel Accents  
Dark Gray Cotton w/ Rolled Edge Hem

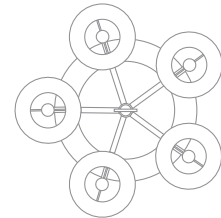

JONATHAN ADLER VENTANA

## PN671

### Tripod Floor Lamp

1 - 150W Max.  
 Bulb Type: A  
 Switch: 3-Way Pull Chain  
 Ebony Finished Wood w/  
 Polished Nickel Accents  
 Natural Linen Shade w/  
 Rolled Edge Hem

FINISH/SHADE OPTIONS:

- 671** Ebony Wood w/ Antique Brass Accents  
Natural Linen w/ Rolled Edge Hem
- AW671** White Wood w/ Polished Nickel Accents  
Ascot White
- WH671** White Wood w/ Polished Nickel Accents  
Dark Gray Cotton w/ Rolled Edge Hem

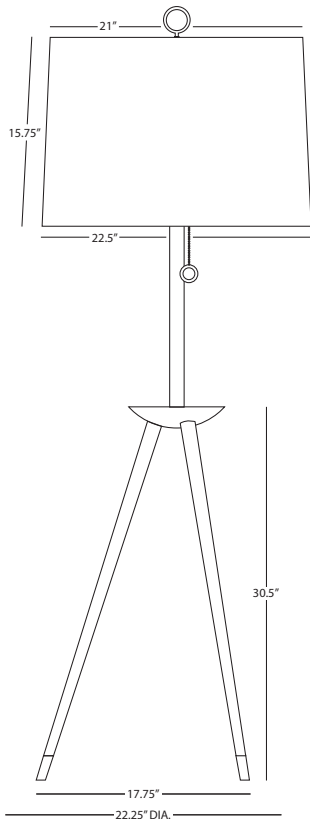

JONATHAN ADLER VENTANA

## WH770

### Spiral Floor Lamp

5 - 40W Max.  
 Bulb Type: B10 Candelabra  
 Switch: On-Off Foot Switch  
 White Finished Wood w/  
 Polished Nickel Accents  
 Dark Gray Cotton Shades w/  
 Rolled Edge Hem

FINISH/SHADE OPTION:

- AW770** White Wood w/ Polished Nickel Accents  
Ascot White

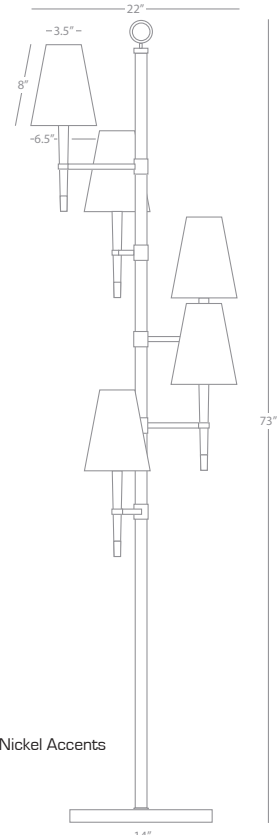

# Jonathan Adler Ventana



673



WH674



# Jonathan Adler Ventana

JONATHAN ADLER VENTANA

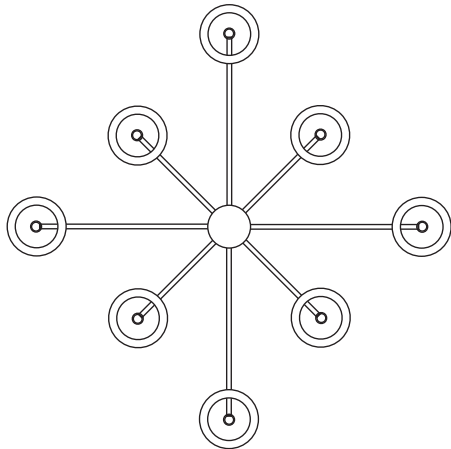

## 673 2-Tier, 8-Light Chandelier

8 - 25W Max.  
Bulb Type: B, Candelabra  
Direct Wire Only  
Ebony Finished Wood w/  
Antique Brass Finished Accents  
Natural Linen Shades w/ Rolled Edge Hem  
Susp. Hardware: 3 pcs. 5/8" x 12"  
& 1 pc. 5/8" x 6" Extensions

### FINISH/SHADE OPTIONS:

- AW673** White Wood w/ Polished Nickel Accents  
Ascot White
- PN673** Ebony Wood w/ Polished Nickel Accents  
Natural Linen w/ Rolled Edge Hem
- WH673** White Wood w/ Polished Nickel Accents  
Dark Gray Cotton w/ Rolled Edge Hem

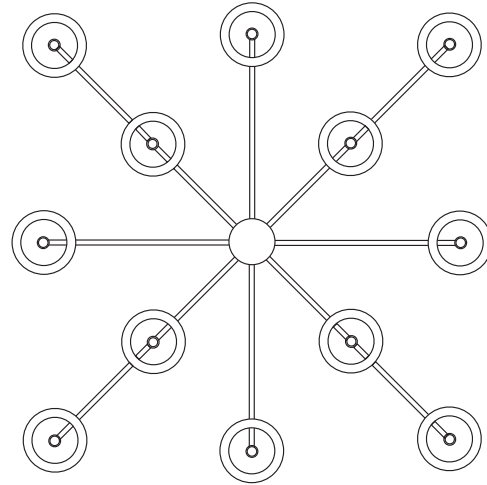
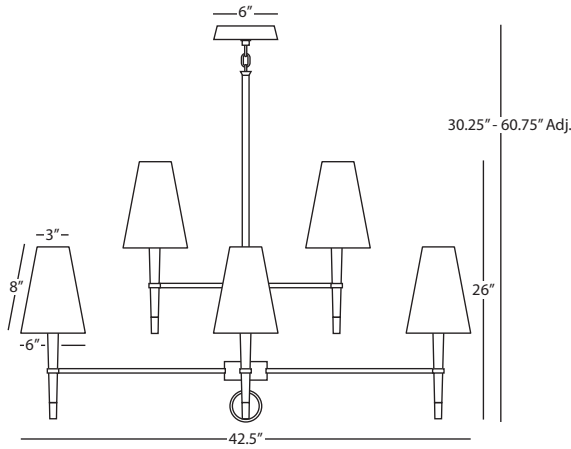

JONATHAN ADLER VENTANA

## WH674 3-Tier, 12-Light Chandelier

12 - 25W Max.  
Bulb Type: B, Candelabra  
Direct Wire Only  
White Finished Wood w/ Polished Nickel Finished Accents  
Dark Gray Cotton Shades w/ Rolled Edge Hem  
Susp. Hardware: 3 pcs. 5/8" x 12"  
& 1 pc. 5/8" x 6" Extensions

### FINISH/SHADE OPTIONS:

- 674** Ebony Wood w/ Antique Brass Accents  
Natural Linen w/ Rolled Edge Hem
- AW674** White Wood w/ Polished Nickel Accents  
Ascot White
- PN674** Ebony Wood w/ Polished Nickel Accents  
Natural Linen w/ Rolled Edge Hem

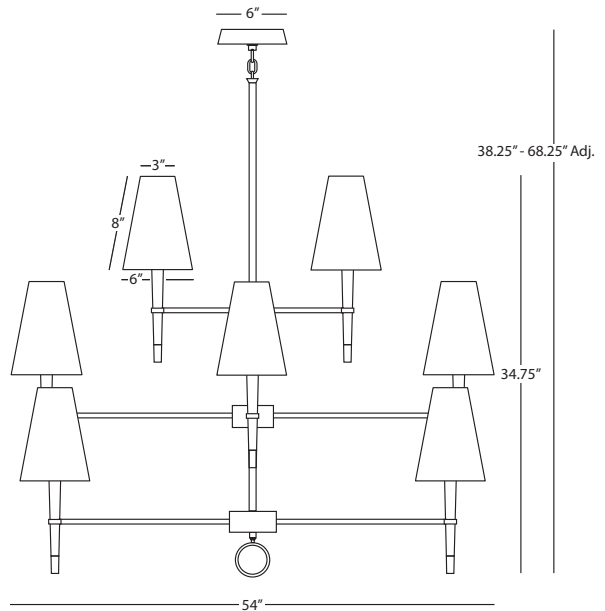

# Jonathan Adler Ventana



PN685



AW718

# Jonathan Adler Ventana

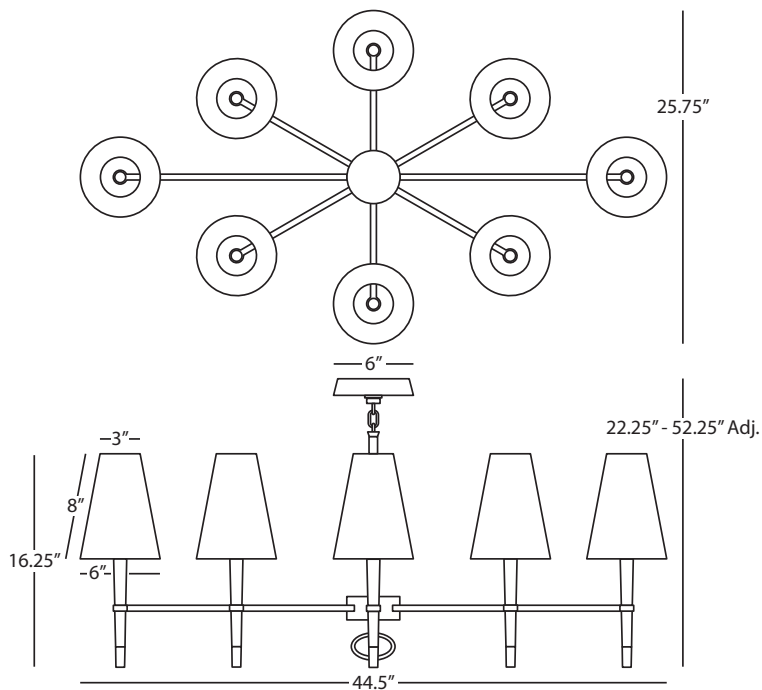

JONATHAN ADLER VENTANA

## AW718 Oval Chandelier

8 - 25W Max.  
Bulb Type: B, Candelabra  
Direct Wire  
White Finished Wood w/ Polished Finished Accents  
Ascot White Shades  
Susp. Hardware: 3 pcs. 5/8" x 12" &  
1 pc. 5/8" x 6" Extensions

FINISH/SHADE OPTIONS:

- 718** Ebony Wood w/ Antique Brass Accents  
Natural Linen w/ Rolled Edge Hem
- PN718** Ebony Wood w/ Polished Nickel Accents  
Natural Linen w/ Rolled Edge Hem
- WH718** White Wood w/ Polished Nickel Accents  
Dark Gray Cotton Shades w/ Rolled Edge Hem

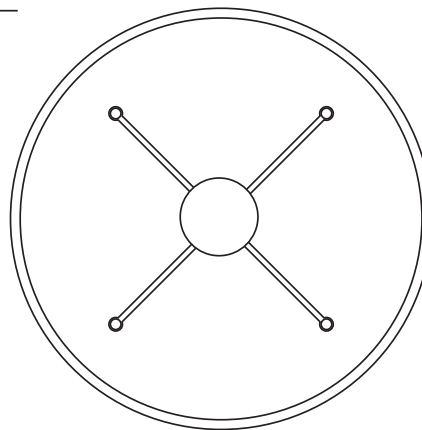

JONATHAN ADLER VENTANA

## PN685 Single Shade Chandelier

4 - 60W Max.  
Bulb Type: B, Candelabra  
Direct Wire Only  
Ebony Finished Wood w/  
Polished Nickel Accents  
Natural Linen Shade w/ Rolled Edge Hem  
Susp. Hardware: 3 pcs. 5/8" x 12"  
& 1 pc. 5/8" x 6" Extensions

FINISH/SHADE OPTIONS:

- 685** Antique Brass Accents

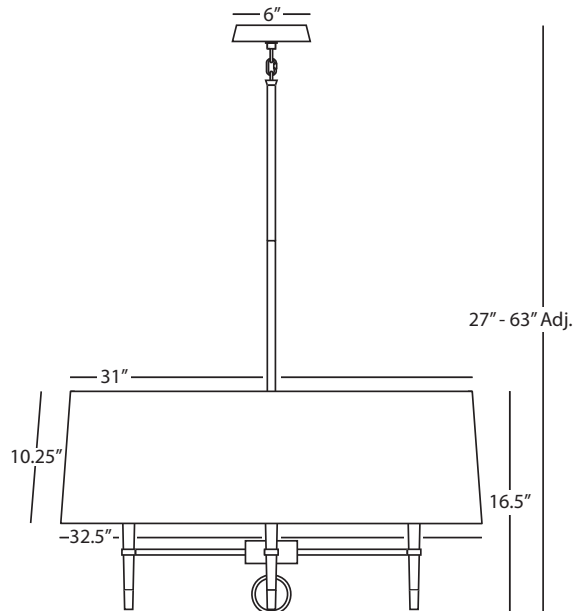

# Jonathan Adler Versailles



C901



W900



B901



A900X



G900X

# Jonathan Adler Versailles

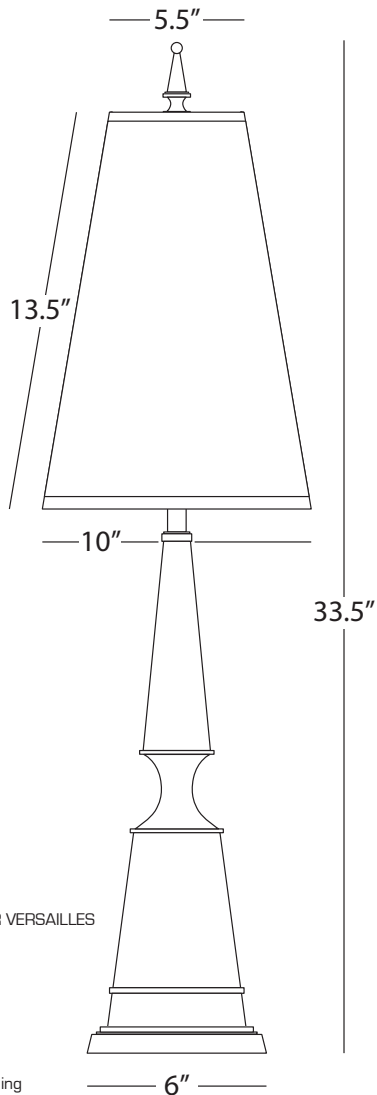

JONATHAN ADLER VERSAILLES

## C901

### Table Lamp

1 - 100W Max.  
Bulb Type: A  
Switch: Hi-Lo Dimming  
Navy Lacquered Paint  
Modern Brass Accents  
Navy Painted Opaque Parchment Shade  
w/ Matte Gold Lining

#### FINISH/SHADE OPTIONS:

<b>A901</b>	Ash Lacquer/Modern Brass Ash Painted Parchment w/ Matte Gold Lining
<b>A901X</b>	Ash Lacquer/Modern Brass Fondine Fabric
<b>B901</b>	Black Lacquer/Modern Brass Black Painted Parchment w/ Matte Gold Lining
<b>B901X</b>	Black Lacquer/Modern Brass Fondine Fabric
<b>C901X</b>	Navy Lacquer/Modern Brass Fondine Fabric
<b>G901</b>	Emerald Lacquer/Modern Brass Emerald Painted Parchment w/ Matte Gold Lining
<b>G901X</b>	Emerald Lacquer/Modern Brass Fondine Fabric
<b>W901</b>	Lily Lacquer/Modern Brass Lily Painted Parchment w/ Matte Gold Lining
<b>W901X</b>	Lily Lacquer/Modern Brass Fondine Fabric

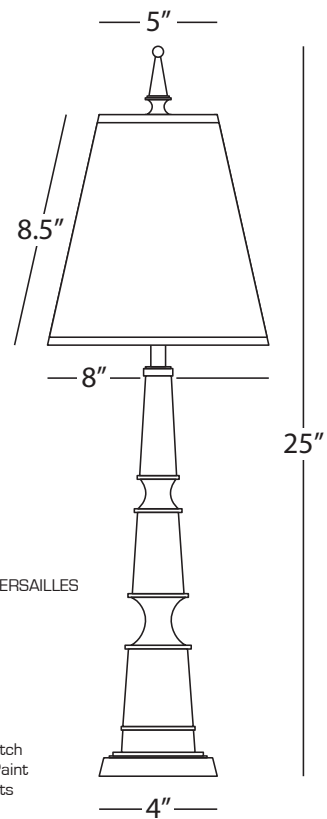

JONATHAN ADLER VERSAILLES

## G900X

### Buffet Lamp

1 - 60W Max.  
Bulb Type: A  
Switch: Hi-Lo Line Switch  
Emerald Lacquered Paint  
Modern Brass Accents  
Fondine Fabric Shade

#### FINISH/SHADE OPTIONS:

<b>A900</b>	Ash Lacquer/Modern Brass Ash Painted Parchment w/ Matte Gold Lining
<b>A900X</b>	Ash Lacquer/Modern Brass Fondine Fabric
<b>B900</b>	Black Lacquer/Modern Brass Black Painted Parchment w/ Matte Gold Lining
<b>B900X</b>	Black Lacquer/Modern Brass Fondine Fabric
<b>C900</b>	Navy Lacquer/Modern Brass Navy Painted Parchment w/ Matte Gold Lining
<b>C900X</b>	Navy Lacquer/Modern Brass Fondine Fabric
<b>G900</b>	Emerald Lacquer/Modern Brass Emerald Painted Parchment w/ Matte Gold Lining
<b>W900</b>	Lily Lacquer/Modern Brass Lily Painted Parchment w/ Matte Gold Lining
<b>W900X</b>	Lily Lacquer/Modern Brass Fondine Fabric

# Jonathan Adler Versailles



W904



A604X



B904



C604X

# Jonathan Adler Versailles

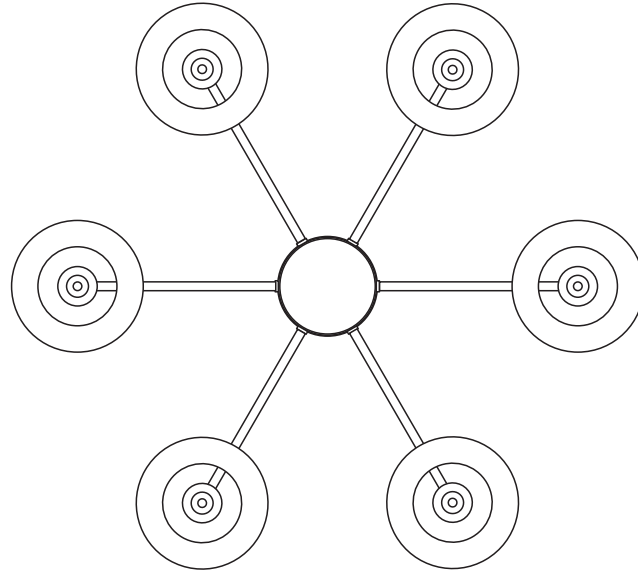

JONATHAN ADLER VERSAILLES

## W904 Chandelier

6 - 60W Max.  
Bulb Type: B, Candelabra  
Direct Wire  
Lily Lacquered Paint  
Modern Brass Accents  
Lily Painted Opaque Parchment Shades  
w/ Matte Gold Lining  
Susp. Hardware: 1 pc. 5/8" x 6" & 3 pcs. 5/8" x 12" Extensions

### FINISH/SHADE OPTIONS:

- A604** Ash Lacquer/Polished Nickel
- Ash Painted Parchment w/ Matte Silver Lining
- A604X** Ash Lacquer/Polished Nickel
- Fondine Fabric
- A904** Ash Lacquer/Modern Brass
- Ash Painted Parchment w/ Matte Gold Lining
- A904X** Ash Lacquer/Modern Brass
- Fondine Fabric
- B604** Black Lacquer/Polished Nickel
- Black Painted Parchment w/ Matte Silver Lining
- B604X** Black Lacquer/Polished Nickel
- Fondine Fabric
- B904** Black Lacquer/Modern Brass
- Black Painted Parchment w/ Matte Gold Lining
- B904X** Black Lacquer/Modern Brass
- Fondine Fabric
- C604** Navy Lacquer/Polished Nickel
- Navy Painted Parchment w/ Matte Silver Lining
- C604X** Navy Lacquer/Polished Nickel
- Fondine Fabric
- C904** Navy Lacquer/Modern Brass
- Navy Painted Parchment w/ Matte Gold Lining
- C904X** Navy Lacquer/Modern Brass
- Fondine Fabric
- G604** Emerald Lacquer/Polished Nickel
- Emerald Painted Parchment w/ Matte Silver Lining
- G604X** Emerald Lacquer/Polished Nickel
- Fondine Fabric
- G904** Emerald Lacquer/Modern Brass
- Emerald Painted Parchment w/ Matte Gold Lining
- G904X** Emerald Lacquer/Modern Brass
- Fondine Fabric
- W604** Lily Lacquer/Polished Nickel
- Lily Painted Parchment w/ Matte Silver Lining
- W604X** Lily Lacquer/Polished Nickel
- Fondine Fabric
- W904X** Lily Lacquer/Modern Brass
- Fondine Fabric

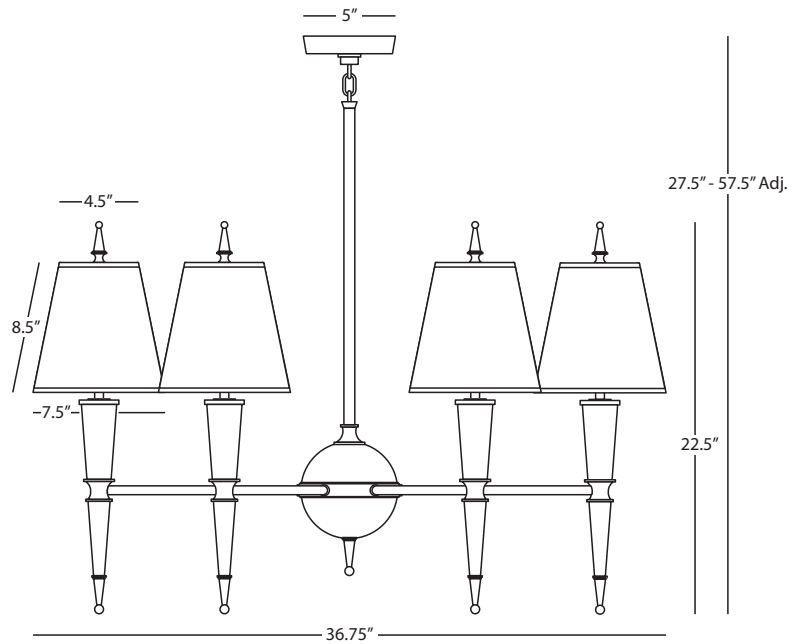

# Jonathan Adler Versailles



A902X



B903



W603



G902



# Jonathan Adler Versailles

JONATHAN ADLER VERSAILLES

## B903

### Wall Sconce

1 - 60W Max.  
 Bulb Type: B, Candelabra  
 Switch: Hi-Lo Dimming  
 24" Cord Cover/Direct Wire  
 Black Lacquered Paint  
 Modern Brass Accents  
 Black Painted Opaque Parchment Shade  
 w/ Matte Gold Lining

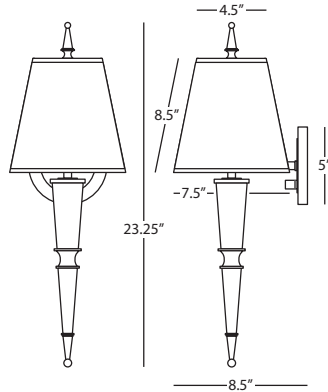

#### FINISH/SHADE OPTIONS:

- A603** Ash Lacquer/Polished Nickel  
Ash Painted Parchment w/ Matte Silver Lining
- A603X** Ash Lacquer/Polished Nickel  
Fondine Fabric
- A903** Ash Lacquer/Modern Brass  
Ash Painted Parchment w/ Matte Gold Lining
- A903X** Ash Lacquer/Modern Brass  
Fondine Fabric
- B603** Black Lacquer/Polished Nickel  
Black Painted Parchment w/ Matte Silver Lining
- B603X** Black Lacquer/Polished Nickel  
Fondine Fabric
- B903X** Black Lacquer/Modern Brass  
Fondine Fabric
- C603** Navy Lacquer/Polished Nickel  
Navy Painted Parchment w/ Matte Silver Lining
- C603X** Navy Lacquer/Polished Nickel  
Fondine Fabric
- C903** Navy Lacquer/Modern Brass  
Navy Painted Parchment w/ Matte Gold Lining
- C903X** Navy Lacquer/Modern Brass  
Fondine Fabric
- G603** Emerald Lacquer/Polished Nickel  
Emerald Painted Parchment w/ Matte Silver Lining
- G603X** Emerald Lacquer/Polished Nickel  
Fondine Fabric
- G903** Emerald Lacquer/Modern Brass  
Emerald Painted Parchment w/ Matte Gold Lining
- G903X** Emerald Lacquer/Modern Brass  
Fondine Fabric
- W603** Lily Lacquer/Polished Nickel  
Lily Painted Parchment w/ Matte Silver Lining
- W603X** Lily Lacquer/Polished Nickel  
Fondine Fabric
- W903** Lily Lacquer/Modern Brass  
Lily Painted Parchment w/ Matte Gold Lining
- W903X** Lily Lacquer/Modern Brass  
Fondine Fabric

JONATHAN ADLER VERSAILLES

## A902X

### Floor Lamp

1 - 150W Max.  
 Bulb Type: A  
 Switch: Hi-Lo Dimming  
 Ash Lacquered Paint  
 Modern Brass Accents  
 Fondine Fabric Shade

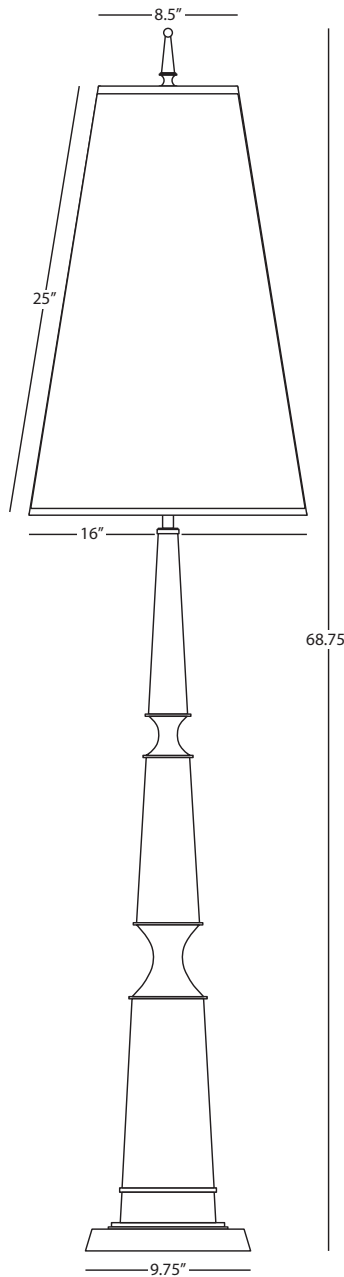

#### FINISH/SHADE OPTIONS:

- A902** Ash Lacquer/Modern Brass  
Ash Painted Parchment w/ Matte Gold Lining
- B902** Black Lacquer/Modern Brass  
Black Painted Parchment w/ Matte Gold Lining
- B902X** Black Lacquer/Modern Brass  
Fondine Fabric
- C902** Navy Lacquer/Modern Brass  
Navy Painted Parchment w/ Matte Gold Lining
- C902X** Navy Lacquer/Modern Brass  
Fondine Fabric
- G902** Emerald Lacquer/Modern Brass  
Emerald Painted Parchment w/ Matte Gold Lining
- G902X** Emerald Lacquer/Modern Brass  
Fondine Fabric
- W902** Lily Lacquer/Modern Brass  
Lily Painted Parchment w/ Matte Gold Lining
- W902X** Lily Lacquer/Modern Brass  
Fondine Fabric



866



920



865

# Jonathan Adler Vienna

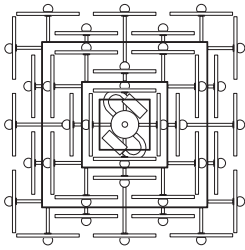

JONATHAN ADLER VIENNA

## 866 Small Chandelier

4 - 60W Max.  
Bulb Type: B, Candelabra  
Direct Wire  
Modern Brass Finish  
Individually Hand Blown Pulegoso Glass  
Susp. Hardware: 3 pcs. 5/8" x 12" & 1 pc. 5/8" x 6" Extensions

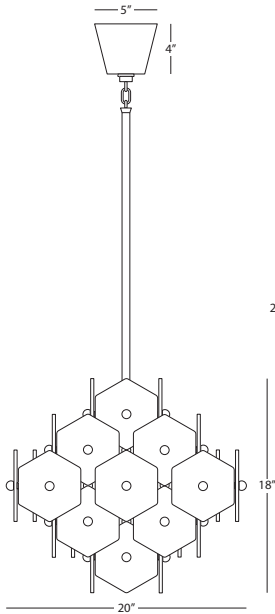

29" - 65" Adj.

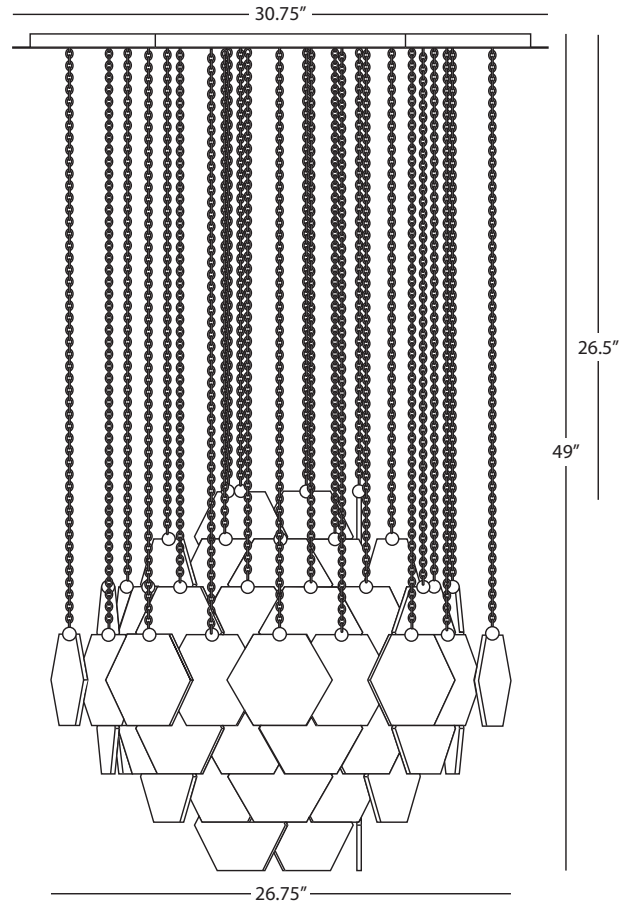

26.5"

49"

26.75"

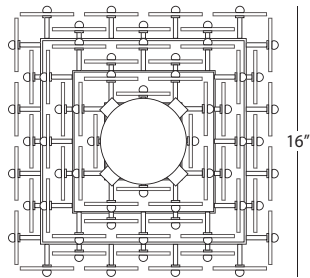

16"

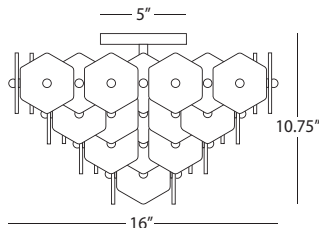

10.75"

16"

JONATHAN ADLER VIENNA

## 920 Semi-Flush Mount

4 - 60W Max.  
Bulb Type: B, Candelabra  
Direct Wire  
Modern Brass Finish  
Individually Hand Blown Pulegoso Glass

JONATHAN ADLER VIENNA

## 865 Large Chandelier

3 - 100W Max.  
Bulb Type: A  
Direct Wire  
Modern Brass Finish  
Individually Hand Blown Pulegoso Glass  
Susp. Hardware: 2 pcs. 5/8" x 12" &  
1 pc. 5/8" x 6" Extensions

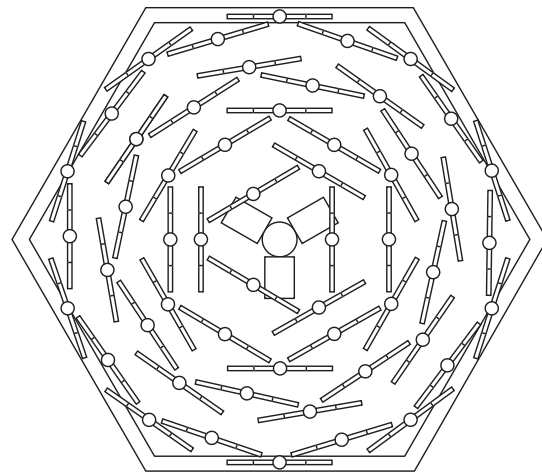

Note: Drop Cannot be Increased Unless an Extension Kit is Purchased (Style # 865K, S865K)



888



899

# Jonathan Adler Vienna

JONATHAN ADLER VIENNA

**888**

## Small Globe Pendant

12 - 60W Max.  
Bulb Type: G, Candelabra  
Direct Wire  
Modern Brass Finish  
Individually Hand Blown White Pulegoso Glass  
Susp. Hardware: 1 pc. 5/8" x 6" &  
3 pcs. 5/8" x 12" Extensions

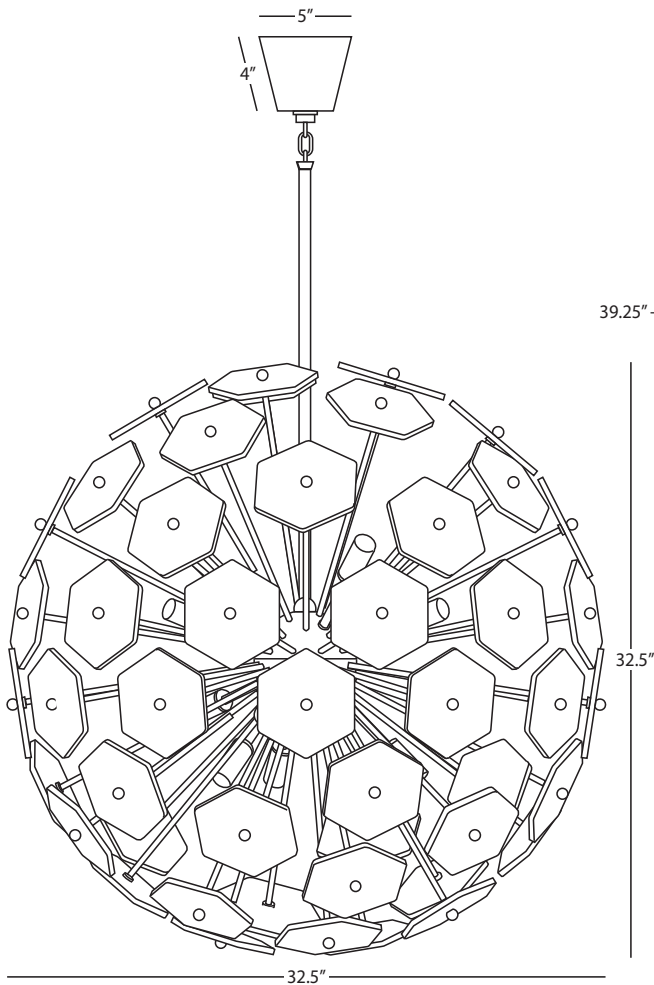
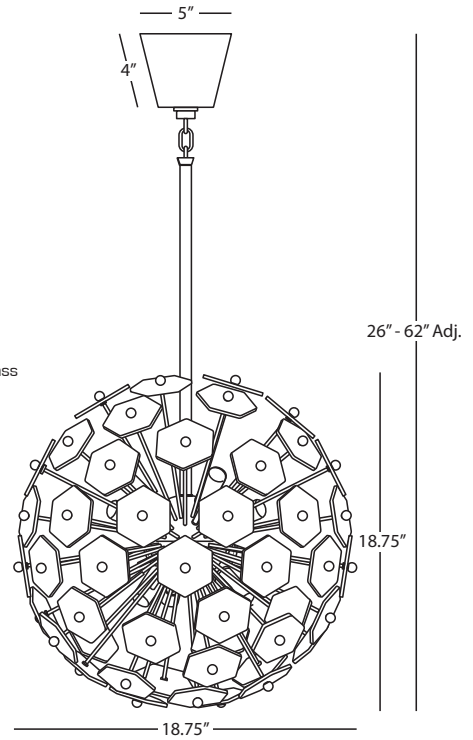

JONATHAN ADLER VIENNA

**899**

## Large Globe Pendant

12 - 60W Max.  
Bulb Type: G, Candelabra  
Direct Wire  
Modern Brass Finish  
Individually Hand Blown White Pulegoso Glass  
Susp. Hardware: 1 pc. 5/8" x 6" &  
3 pcs. 5/8" x 12" Extensions

# WILLIAMSBURG



Photograph courtesy of The Colonial Williamsburg Foundation

Trend meets tradition in the WILLIAMSBURG collection. Inspired by 18th-century patterns in rare books, architectural details in the “Revolutionary City,” and decorative details and colors in the vast design archive of the Colonial Williamsburg Foundation, Robert Abbey’s talented design team has developed lamps and fixtures with timeless style and contemporary appeal. They’ve channeled global chic from England’s 18th-century trade goods and paired Asian elegance with urns that represent the classical foundations of British and American architectural heritage.

WILLIAMSBURG is the brand of The Colonial Williamsburg Foundation, the large not-for-profit organization that keeps history alive by maintaining the country’s oldest and largest outdoor history museum. Here, visionaries like Thomas Jefferson and Patrick Henry debated the promise—and perils—of a revolution that would change the course of history and lead to the founding of the United States of America. Sales of WILLIAMSBURG products support the mission of historical education, preservation, and the nurture of active citizen engagement.

Established in 1936, WILLIAMSBURG invented licensing of museum-based home furnishings. Today they collaborate with over 40 licensees, including Robert Abbey, Inc., Benjamin Moore, and Global Views, to offer classic American style for the way we live today. To learn more about the licensing program, visit [www.WILLIAMSBURGbrand.com](http://www.WILLIAMSBURGbrand.com). To learn more about The Colonial Williamsburg Foundation, visit [www.colonialwilliamsburg.com](http://www.colonialwilliamsburg.com).

© 2019 The Colonial Williamsburg Foundation  
WILLIAMSBURG is a trademark of The Colonial Williamsburg Foundation.



WB331



BW997

WILLIAMSBURG



S439



260



358



WB336



WB339



BN333



BN347



WB348



WB342



WB330



BN334



BN328



BN341



WB345



BN350



# WILLIAMSBURG Custis

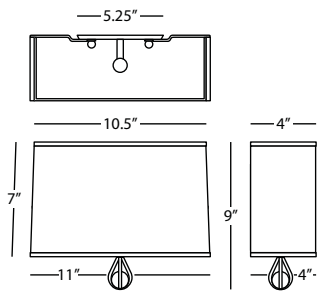

WILLIAMSBURG CUSTIS

## BN341

### Wall Sconce

1 - 40W Max.  
 Bulb Type: B, Candelabra  
 Direct Wire Only  
 Modern Brass Finish  
 Lead Crystal Finial  
 Carter Gray Fabric Shade  
 w/ Mayo Teal Lining  
 ADA Compliant

#### FINISH/SHADE OPTIONS:

- BN340** Modern Brass  
Mayo Teal/ Carter Gray Lining
- WB340** Polished Nickel  
Mayo Teal/ Carter Gray Lining
- WB341** Polished Nickel  
Carter Gray/ Mayo Teal Lining
- BN342** Modern Brass  
Parrot Green/ Revolutionary Storm Lining
- WB342** Polished Nickel  
Parrot Green/ Revolutionary Storm Lining
- BN343** Modern Brass  
Revolutionary Storm/ Parrot Green Lining
- WB343** Polished Nickel  
Revolutionary Storm/ Parrot Green Lining
- BN344** Modern Brass  
Greenhow Grape/ Ludwell Lilac Lining
- WB344** Polished Nickel  
Greenhow Grape/ Ludwell Lilac Lining
- BN345** Modern Brass  
Ludwell Lilac/ Greenhow Grape Lining
- WB345** Polished Nickel  
Ludwell Lilac/ Greenhow Grape Lining
- BN346** Modern Brass  
Revolutionary Storm/ William of Orange Lining
- WB346** Polished Nickel  
Revolutionary Storm/ William of Orange Lining
- BN347** Modern Brass  
William of Orange/ Revolutionary Storm Lining
- WB347** Polished Nickel  
William of Orange/ Revolutionary Storm Lining
- BN348** Modern Brass  
Richmond Red/ Blacksmith Black Lining
- WB348** Polished Nickel  
Richmond Red/ Blacksmith Black Lining
- BN349** Modern Brass  
Blacksmith Black/ Richmond Red Lining
- WB349** Polished Nickel  
Blacksmith Black/ Richmond Red Lining
- BN350** Modern Brass  
Ink Blue/ Carter Gray Lining
- WB350** Polished Nickel  
Ink Blue/ Carter Gray Lining
- BN351** Modern Brass  
Carter Gray/ Ink Blue Lining
- WB351** Polished Nickel  
Carter Gray/ Ink Blue Lining

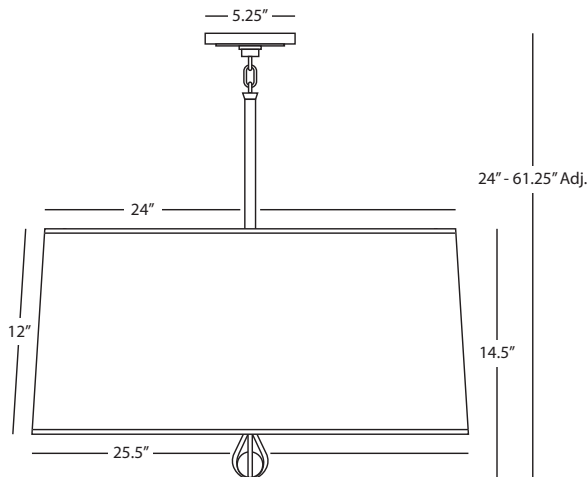

WILLIAMSBURG CUSTIS

## BN328

### Pendant

3 - 100W Max.  
 Bulb Type: A  
 Direct Wire  
 Modern Brass Finish  
 Lead Crystal Finial  
 Ink Blue Fabric Shade w/  
 Carter Gray Lining  
 13.25" Dia. Polished Nickel Metal Diffuser  
 Susp. Hardware: 3 pcs. 5/8" x 12" &  
 1 pc. 5/8" x 6" Extensions

#### FINISH/SHADE OPTIONS:

- WB328** Polished Nickel  
Ink Blue/ Carter Gray Lining
- BN329** Modern Brass  
Carter Gray/ Ink Blue Lining
- WB329** Polished Nickel  
Carter Gray/ Ink Blue Lining
- BN330** Modern Brass  
Mayo Teal/ Carter Gray Lining
- WB330** Polished Nickel  
Mayo Teal/ Carter Gray Lining
- BN331** Modern Brass  
Carter Gray/ Mayo Teal Lining
- WB331** Polished Nickel  
Carter Gray/ Mayo Teal Lining
- BN332** Modern Brass  
Parrot Green/ Revolutionary Storm Lining
- WB332** Polished Nickel  
Parrot Green/ Revolutionary Storm Lining
- BN333** Modern Brass  
Revolutionary Storm/ Parrot Green Lining
- WB333** Polished Nickel  
Revolutionary Storm/ Parrot Green Lining
- BN334** Modern Brass  
Greenhow Grape/ Ludwell Lilac Lining
- WB334** Polished Nickel  
Greenhow Grape/ Ludwell Lilac Lining
- BN335** Modern Brass  
Ludwell Lilac/ Greenhow Grape Lining
- WB335** Polished Nickel  
Ludwell Lilac/ Greenhow Grape Lining
- BN336** Modern Brass  
Revolutionary Storm/ William of Orange Lining
- WB336** Polished Nickel  
Revolutionary Storm/ William of Orange Lining
- BN337** Modern Brass  
William of Orange/ Revolutionary Storm Lining
- WB337** Polished Nickel  
William of Orange/ Revolutionary Storm Lining
- BN338** Modern Brass  
Richmond Red/ Blacksmith Black Lining
- WB338** Polished Nickel  
Richmond Red/ Blacksmith Black Lining
- BN339** Modern Brass  
Blacksmith Black/ Richmond Red Lining
- WB339** Polished Nickel  
Blacksmith Black/ Richmond Red Lining

WILLIAMSBURG Etoile



527

# WILLIAMSBURG Etoile

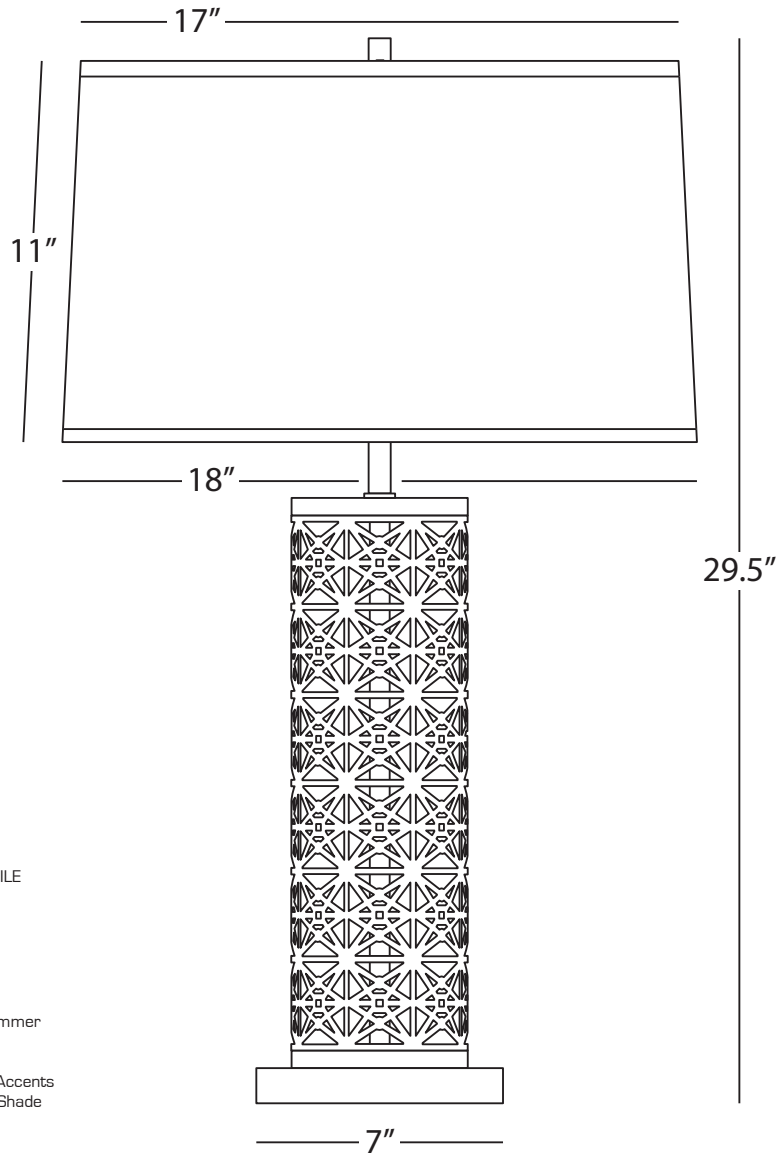

WILLIAMSBURG ETOILE

**527**

Table Lamp

1 - 150W Max.  
Bulb Type: A  
Switch: Full Range Dimmer  
Laser Cut Pattern  
Warm Brass Finish  
Deep Patina Bronze Accents  
Pearl Dupioni Fabric Shade

# WILLIAMSBURG Finnie



358



362



S359

# WILLIAMSBURG Finnie

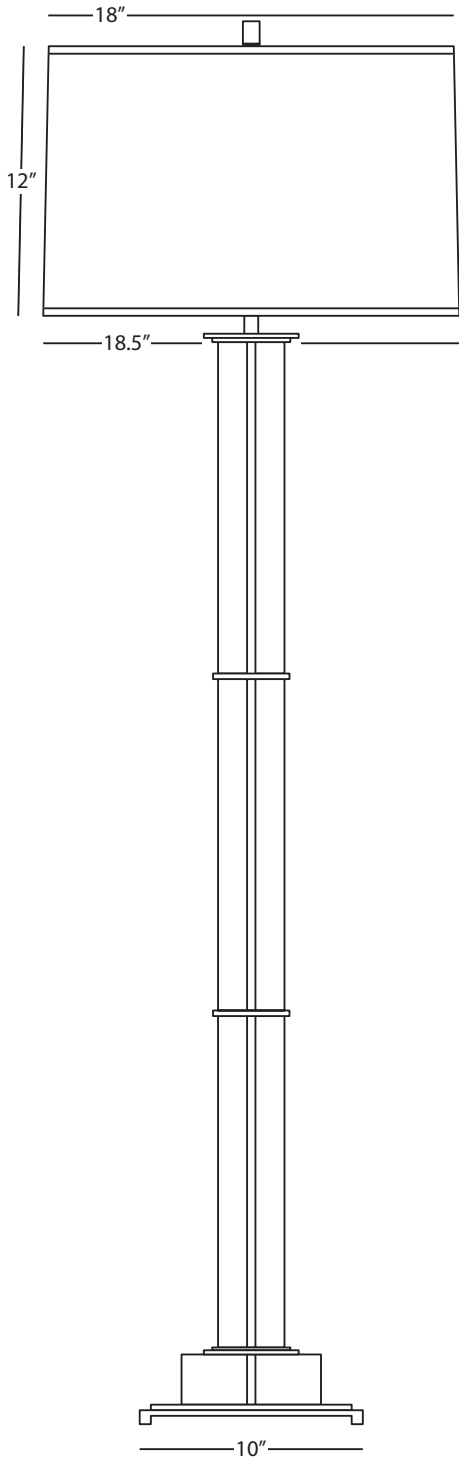

WILLIAMSBURG FINNIE

## 362 Accent Lamp

1 - 60W Max.  
Bulb Type: G16.5, Candelabra  
Switch: Hi-Lo Line Switch  
Modern Brass Finish  
Clear Lead Crystal  
Cloud Cream Shade w/  
Self-Fabric Top Diffuser

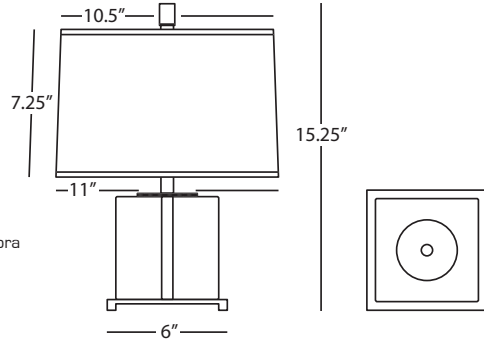

WILLIAMSBURG FINNIE

## 358 Floor Lamp

1 - 150W Max.  
Bulb Type: A  
Switch: Hi-Lo Dimming  
Modern Brass Finish  
Clear Lead Crystal  
Cloud Cream Silk Shade

62.5"

WILLIAMSBURG FINNIE

## S359 Table Lamp

1 - 150W Max.  
Bulb Type: A  
Switch: Hi-Lo Dimming  
Polished Nickel Finish  
Clear Lead Crystal  
White Silk Shade

FINISH/SHADE OPTION:  
**359** Modern Brass/  
Cloud Cream Silk

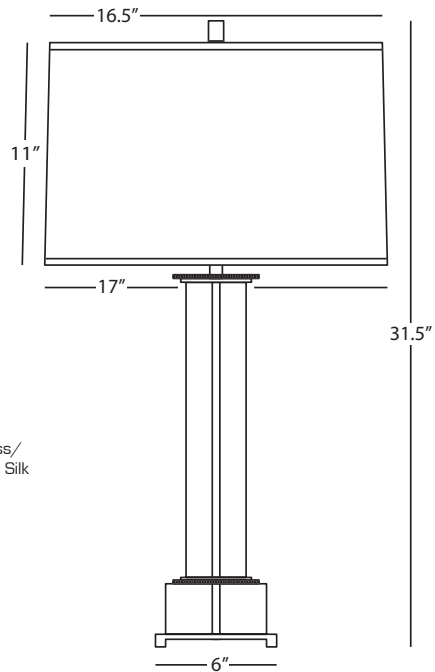

# WILLIAMSBURG Lightfoot



1031



1035



S1033



S1030



Z1032



Z1034

# WILLIAMSBURG Lightfoot

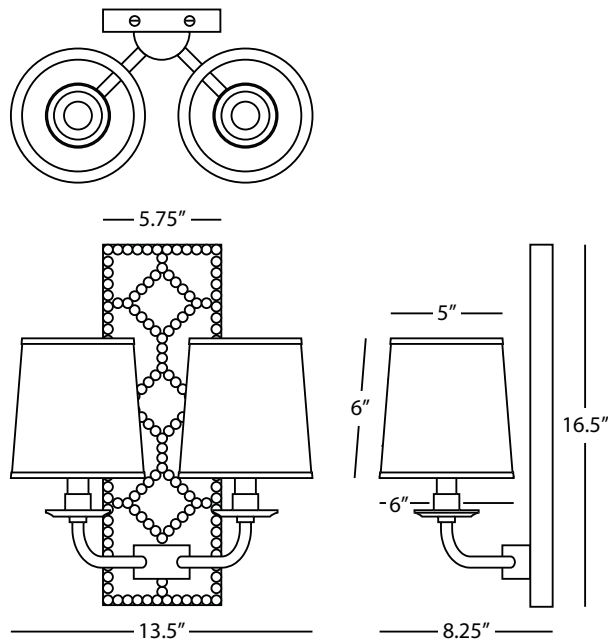

WILLIAMSBURG LIGHTFOOT

## 1031

### Double Sconce

2 - 60W Max.  
Bulb Type: B, Candelabra  
Direct Wire Only  
Backplate Upholstered in Dragons Blood  
Leather w/ Nailhead Detail  
Aged Brass Accents  
Fondine Fabric Shades

FINISH OPTIONS:

**S1031** Polished Nickel Accents  
**Z1031** Deep Patina Bronze Accents

WILLIAMSBURG LIGHTFOOT

## 1035

### Double Sconce

2 - 60W Max.  
Bulb Type: B, Candelabra  
Direct Wire Only  
Backplate Upholstered in Blacksmith Black  
Leather w/ Nailhead Detail  
Aged Brass Accents  
Fondine Fabric Shades

FINISH OPTIONS:

**S1035** Polished Nickel Accents  
**Z1035** Deep Patina Bronze Accents

WILLIAMSBURG LIGHTFOOT

## S1033

### Double Sconce

2 - 60W Max.  
Bulb Type: B, Candelabra  
Direct Wire Only  
Backplate Upholstered in Worcester Peacock  
Leather w/ Nailhead Detail  
Polished Nickel Accents  
Fondine Fabric Shades

FINISH OPTIONS:

**1033** Aged Brass Accents  
**Z1033** Deep Patina Bronze Accents

WILLIAMSBURG LIGHTFOOT

## S1030

### Double Sconce

2 - 60W Max.  
Bulb Type: B, Candelabra  
Direct Wire Only  
Backplate Upholstered in English Ochre  
Leather w/ Nailhead Detail  
Polished Nickel Accents  
Fondine Fabric Shades

FINISH OPTIONS:

**1030** Aged Brass Accents  
**Z1030** Deep Patina Bronze Accents

WILLIAMSBURG LIGHTFOOT

## Z1032

### Double Sconce

2 - 60W Max.  
Bulb Type: B, Candelabra  
Direct Wire Only  
Backplate Upholstered in Bruton White  
Leather w/ Nailhead Detail  
Deep Patina Bronze Accents  
Fondine Fabric Shades

FINISH OPTIONS:

**1032** Aged Brass Accents  
**S1032** Polished Nickel Accents

WILLIAMSBURG LIGHTFOOT

## Z1034

### Double Sconce

2 - 60W Max.  
Bulb Type: B, Candelabra  
Direct Wire Only  
Backplate Upholstered in Carter Gray  
Leather w/ Nailhead Detail  
Deep Patina Bronze Accents  
Fondine Fabric Shades

FINISH OPTIONS:

**1034** Aged Brass Accents  
**S1034** Polished Nickel Accents



260

Z260B

S260B



# WILLIAMSBURG Orlando

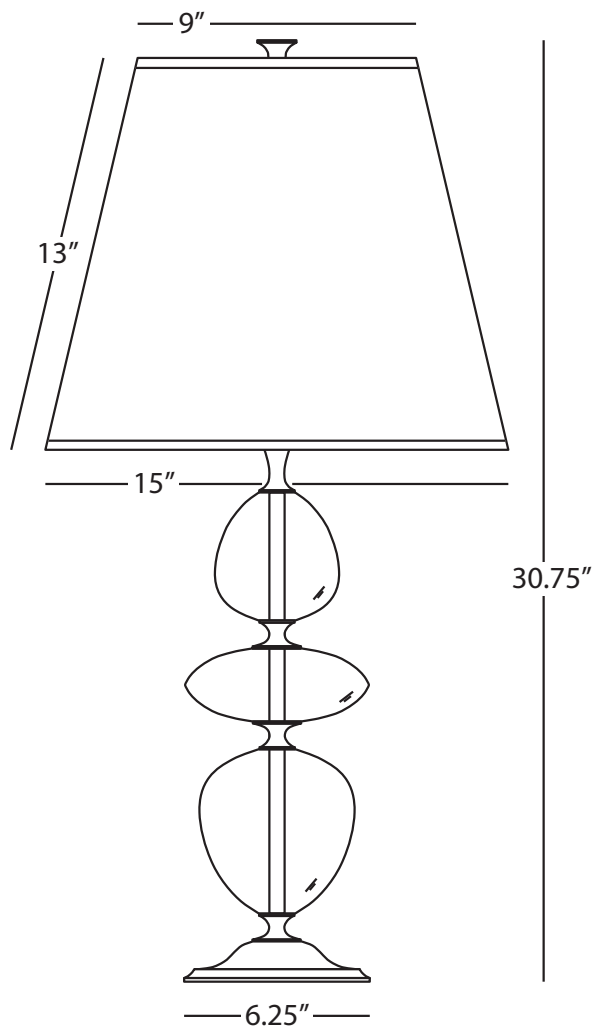

WILLIAMSBURG ORLANDO

## 260 Table Lamp

1 - 150W Max.  
Bulb Type: A  
Switch: Full Range Dimmer  
Clear Crystal w/  
Modern Brass Accents  
Oyster Linen Shade

### FINISH/SHADE OPTIONS:

- 260B** Modern Brass/Black Parchment w/ Matte Gold Lining
- S260** Polished Nickel/Oyster Linen
- S260B** Polished Nickel/Black Parchment w/ Matte Silver Lining
- Z260** Deep Patina Bronze/Oyster Linen
- Z260B** Deep Patina Bronze/Black Parchment w/ Matte Silver Lining

# WILLIAMSBURG Randolph



LB997



DB997



CG997



CP997



BW997



PG997



MT997

# WILLIAMSBURG Randolph

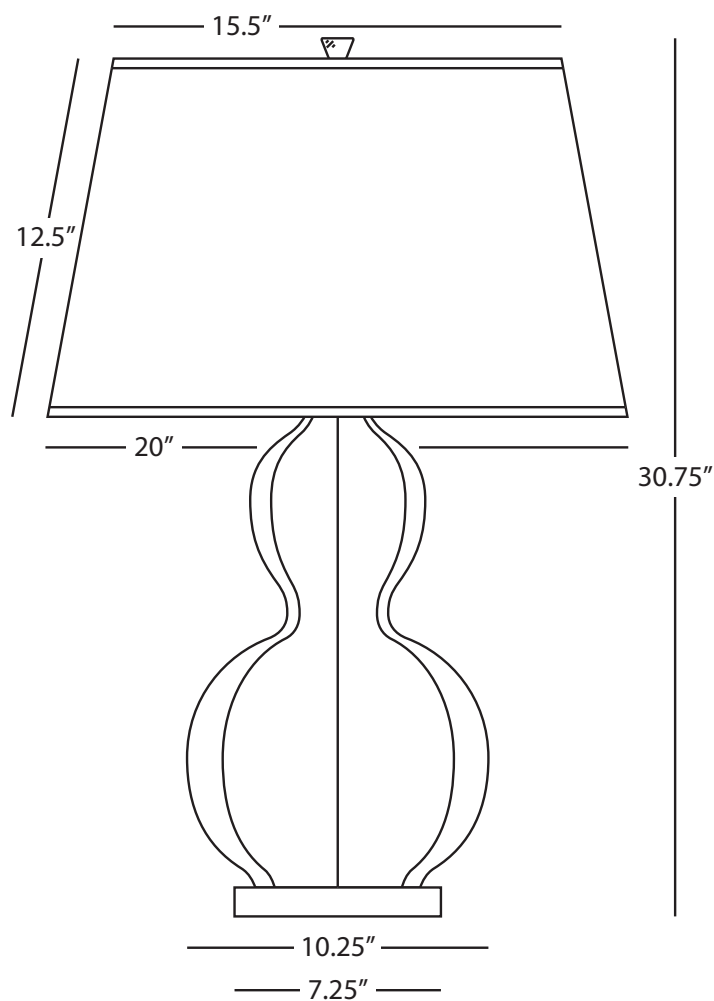

WILLIAMSBURG RANDOLPH

## BW997

### Table Lamp

1 - 150W Max.

Bulb Type: A

Switch: Hi-Lo Dimming

Bruton White (Soft Gray) Glazed Ceramic

w/ Polished Nickel Metal Parts

Lucite Base

Pearl Dupioni Fabric Shade

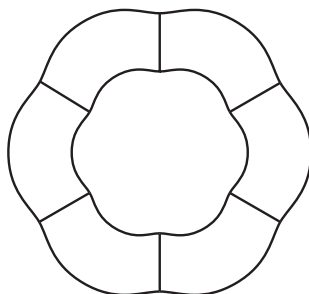

#### COLOR OPTIONS:

- CG997** Carter Gray (Gray-Taupe)
- CP997** Carter Plum (Deep Mauve)
- DB997** Dragons Blood (Rusty Orange-Red)
- LB997** Lampblack (Dark Gray)
- MT997** Mayo Teal (Blue-Green)
- PG997** Parrot Green (Muted Chartreuse)

# WILLIAMSBURG Spotswood



S150



150

# WILLIAMSBURG Spotswood

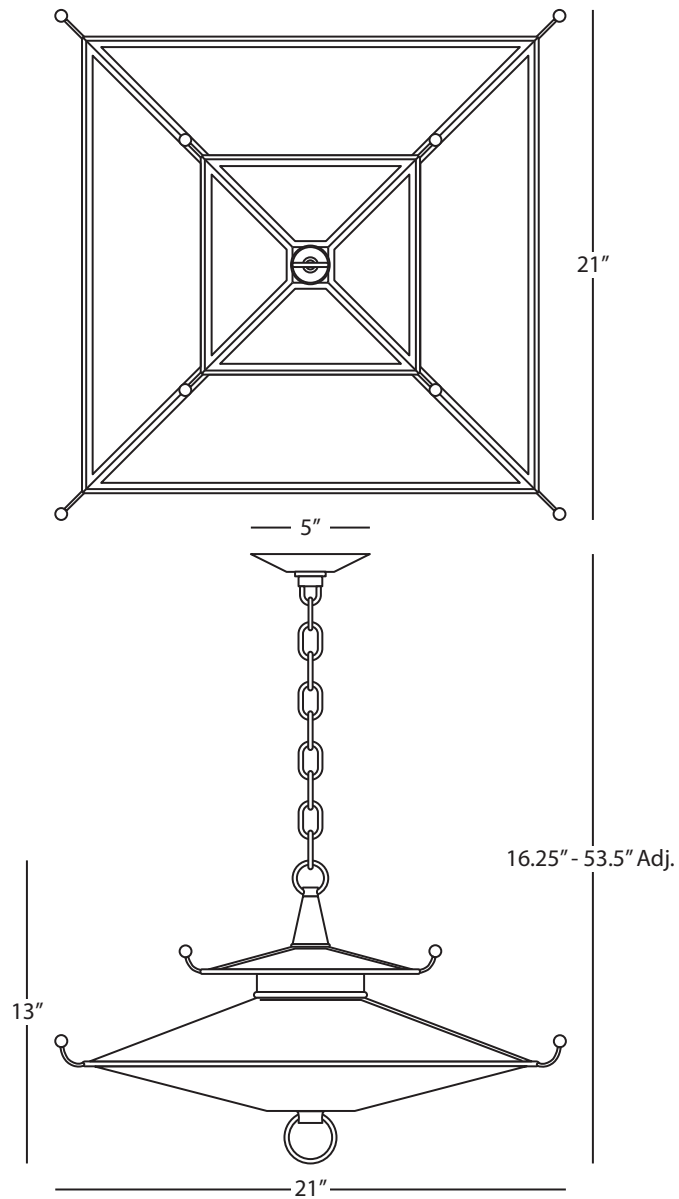

WILLIAMSBURG SPOTSWOOD

## 150

### Pendant

1 - 23W Max. LED Unit  
(2300 Lumen Output)  
Bulb Type: LED, Included (Non-replaceable)  
LED Color Temp: 3000K, CRI: 80  
Direct Wire  
Deep Patina Bronze Finish w/  
Modern Brass Accents  
Frosted Acrylic Diffuser  
Susp. Hardware: 3 Ft. Chain

#### FINISH OPTION:

**S150** Antique Silver Accents



439



S438

# WILLIAMSBURG Tazewell

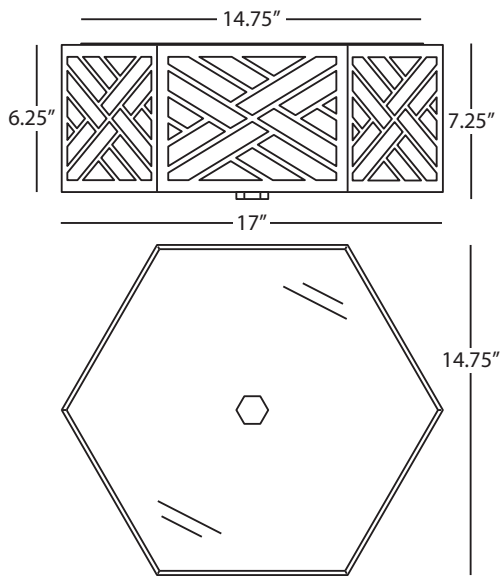

WILLIAMSBURG TAZEWell

## S438

### Flush Mount

1 - 23W Max. LED Unit  
(2540 Lumen Output)  
Bulb Type: LED, Included (Non-replaceable)  
LED Color Temp: 3000K, CRI: 80  
Direct Wire  
Polished Nickel Finish  
Printed White Glass Shade Panels

FINISH OPTION:

**438** Modern Brass

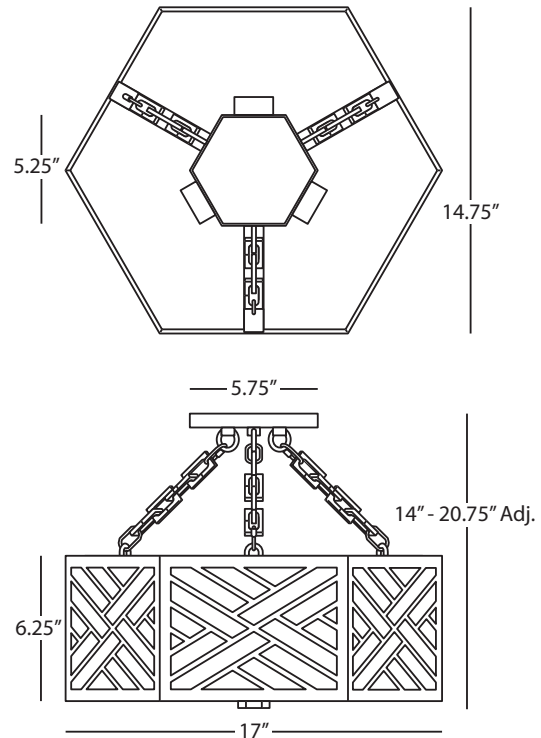

WILLIAMSBURG TAZEWell

## 439

### Semi-Flush Mount

1 - 23W Max. LED Unit  
(2540 Lumen Output)  
Bulb Type: LED, Included (Non-replaceable)  
LED Color Temp: 3000K, CRI: 80  
Direct Wire  
Modern Brass Finish  
Printed White Glass Shade Panels  
Susp. Hardware: 9" Chain (x3)

FINISH OPTION:

**S439** Polished Nickel



Z307



S306



# WILLIAMSBURG Tucker

WILLIAMSBURG TUCKER

## 306

Small Flush Mount

2 - 40W Max.  
Bulb Type: B, Medium  
Direct Wire  
Antique Brass Finish  
Frosted White Cased Glass Shade

FINISH OPTIONS:

**S306** Polished Nickel  
**Z306** Deep Patina Bronze

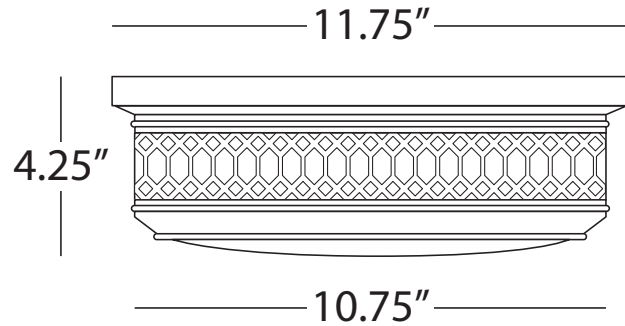

WILLIAMSBURG TUCKER

## Z307

Large Flush Mount

3 - 40W Max.  
Bulb Type: B, Medium  
Direct Wire  
Deep Patina Bronze Finish  
Frosted White Cased Glass Shade

FINISH OPTIONS:

**307** Antique Brass  
**S307** Polished Nickel

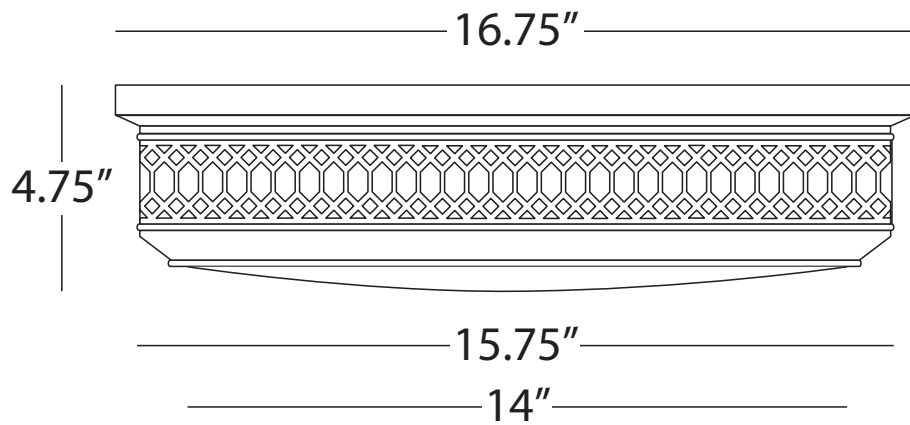

# WILLIAMSBURG Tyrie



411



Z411

# WILLIAMSBURG Tyrie

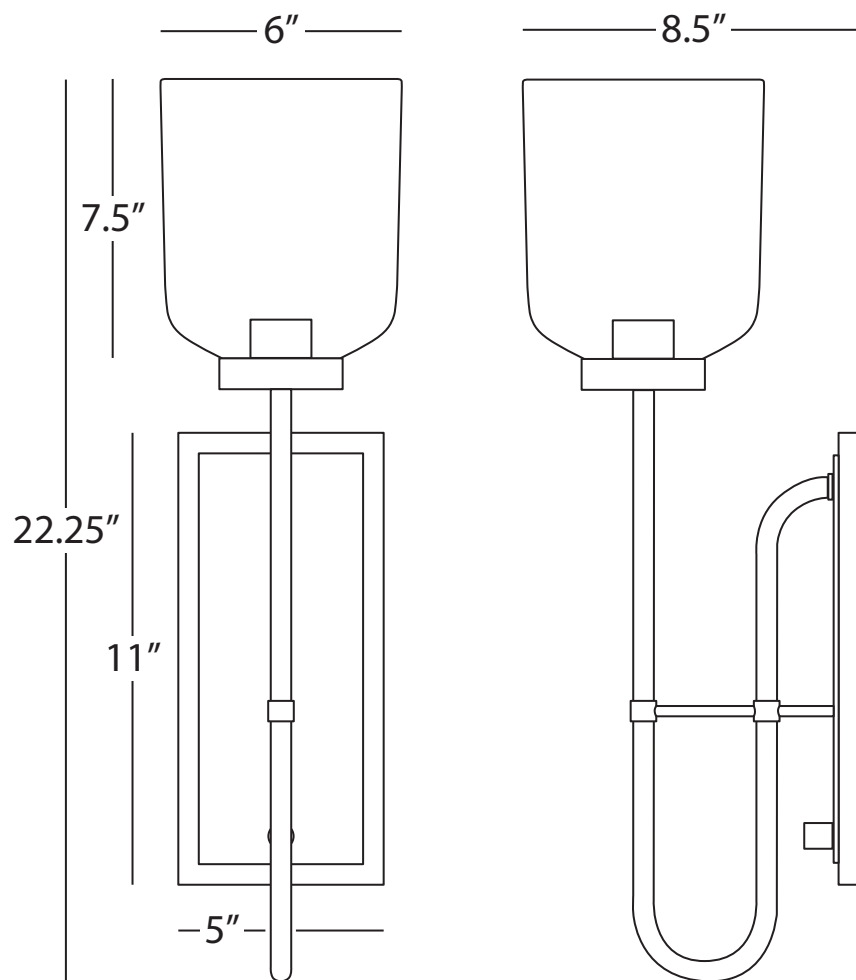

WILLIAMSBURG TYRIE

**411**

Wall Sconce

1 - 100W Max.  
Bulb Type: A  
Switch: Hi-Lo Dimming  
24" Cord Cover/Direct Wire  
Antique Brass Finish  
Clear Glass Shade

Photographed with Historical Bulb  
SOLD SEPARATELY  
(HISO1 See Page 225)

FINISH OPTIONS:

**D411** Dark Antique Nickel  
**Z411** Deep Patina Bronze



## MICHAEL BERMAN

Renowned interiors and product designer Michael Berman has created a portfolio of projects that span the globe. From residential homes to luxury hotels, his signature “Trans-Modern” American style reflects the designer’s interest in history, art, architecture, and nature, forming a heady mix of completely livable – and widely celebrated – interiors, furniture, lighting, and textiles. His work strikes an uncommon balance between timeless style and of-the-moment relevance inspired by comfort, American Modernism, simplicity of form, and classic Hollywood glamour. Berman’s work resonates with design industry colleagues for its attention to detail and usable scale. Michael has crafted an epic romance that blends the luxury of casual lifestyle and eclectic cinematic swank. “My objective is to create classics with restraint and elegance that will stand the test of time.”

Berman is the founder and principal creative visionary behind his west coast based Bronze Studio and Michael Berman Limited, a multi-faceted design firm focusing on interiors, architecture, furniture, and all aspirational products for home design.



Upholstery by Wesley Hall Inc.

# MICHAEL BERMAN



626



MCR21



543



MDV21



MDC20



MWR22



MSB21



MMB20



MCR22

# Michael Berman Atlas

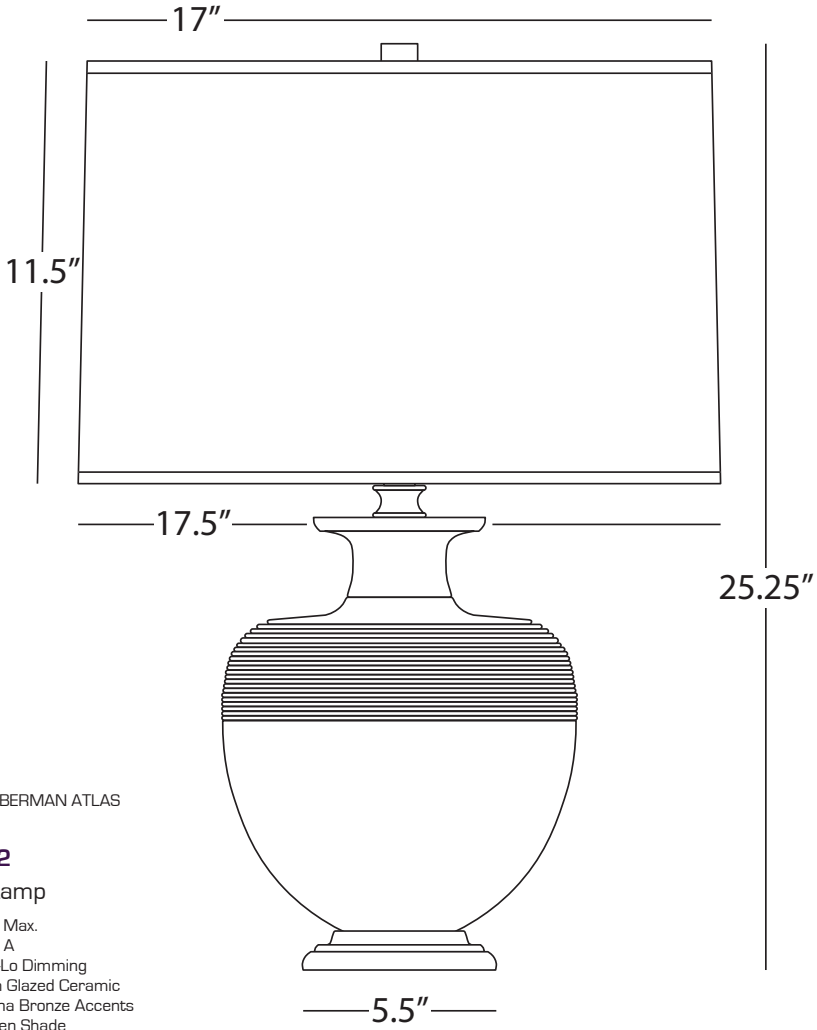

MICHAEL BERMAN ATLAS

**MCR22**

Table Lamp

- 1 - 150W Max.
- Bulb Type: A
- Switch: Hi-Lo Dimming
- Matte Ash Glazed Ceramic
- Deep Patina Bronze Accents
- Oyster Linen Shade

See Page 239 for Color/Base Options

Michael Berman Berkley



573



572W



574W



570W



571



# Michael Berman Berkley

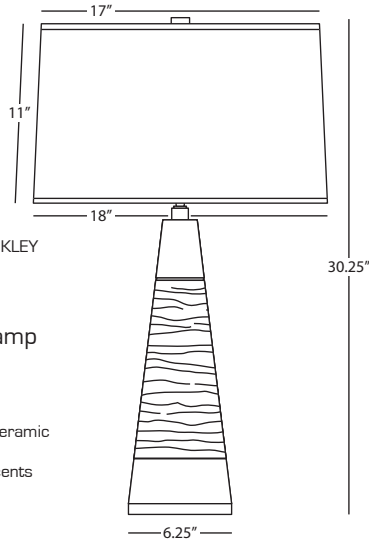

MICHAEL BERMAN BERKLEY

## 571 Tapered Table Lamp

1 - 150W Max.  
Bulb Type: A  
Switch: Hi-Lo Dimming  
Antique Oyster Glazed Ceramic  
Walnut Finished Wood  
Deep Patina Bronze Accents  
Bisque Linen Shade

SHADE OPTION:  
**571W** Cream Brussels Linen

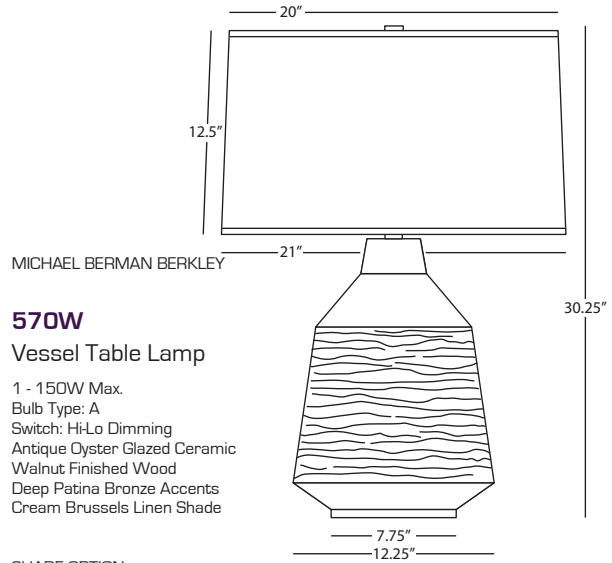

MICHAEL BERMAN BERKLEY

## 570W Vessel Table Lamp

1 - 150W Max.  
Bulb Type: A  
Switch: Hi-Lo Dimming  
Antique Oyster Glazed Ceramic  
Walnut Finished Wood  
Deep Patina Bronze Accents  
Cream Brussels Linen Shade

SHADE OPTION:  
**570** Bisque Linen

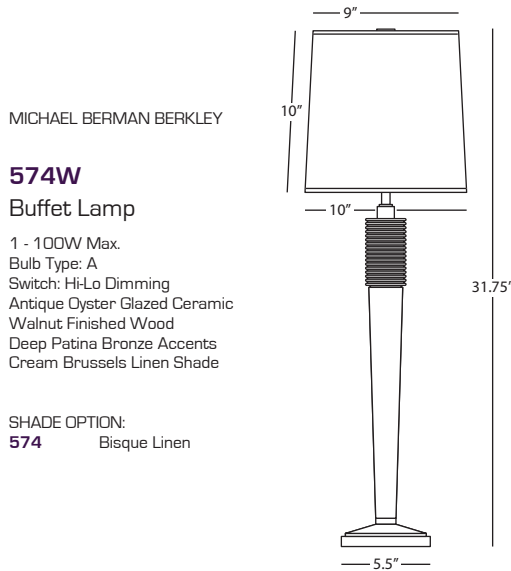

MICHAEL BERMAN BERKLEY

## 574W Buffet Lamp

1 - 100W Max.  
Bulb Type: A  
Switch: Hi-Lo Dimming  
Antique Oyster Glazed Ceramic  
Walnut Finished Wood  
Deep Patina Bronze Accents  
Cream Brussels Linen Shade

SHADE OPTION:  
**574** Bisque Linen

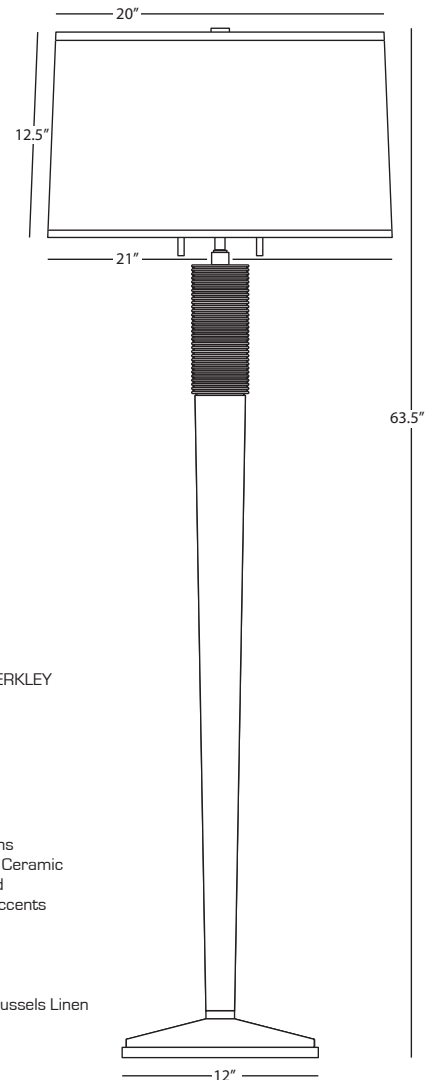

MICHAEL BERMAN BERKLEY

## 573 Floor Lamp

2 - 100W Max.  
Bulb Type: A  
Switch: Hi-Lo Pull Chains  
Antique Oyster Glazed Ceramic  
Walnut Finished Wood  
Deep Patina Bronze Accents  
Bisque Linen Shade

SHADE OPTION:  
**573W** Cream Brussels Linen

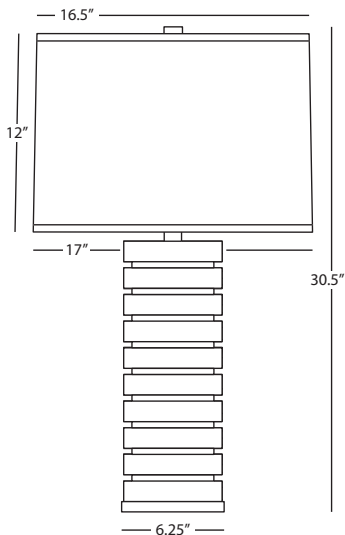

MICHAEL BERMAN BERKLEY

## 572W Stacked Table Lamp

1 - 150W Max.  
Bulb Type: A  
Switch: Hi-Lo Dimming  
Antique Oyster Glazed Ceramic  
Walnut Finished Wood  
Deep Patina Bronze Accents  
Cream Brussels Linen Shade

SHADE OPTION:  
**572** Bisque Linen



545



533



553W

# Michael Berman Bond

MICHAEL BERMAN BOND

## 545

### Flush Mount

3 - 60W Max.  
 Bulb Type: A  
 Direct Wire  
 Deep Patina Bronze Finish  
 White Glass Shade Panels  
 UL Rated for Damp Locations

FINISH OPTIONS:

**535** Modern Brass  
**555** Blackened Nickel

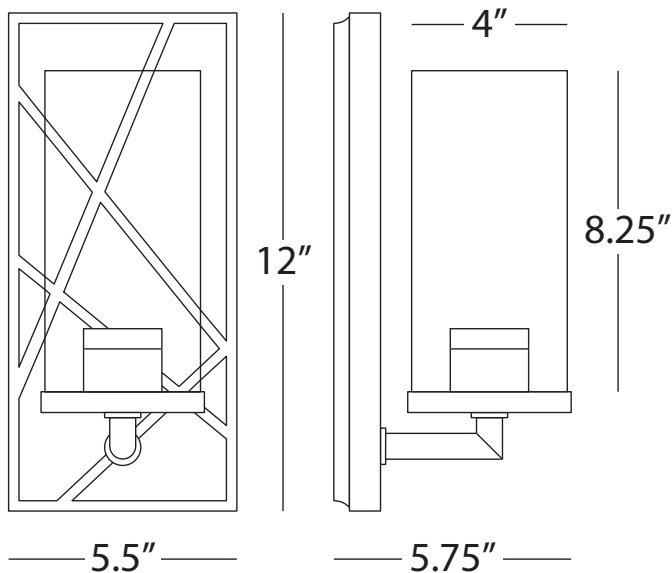
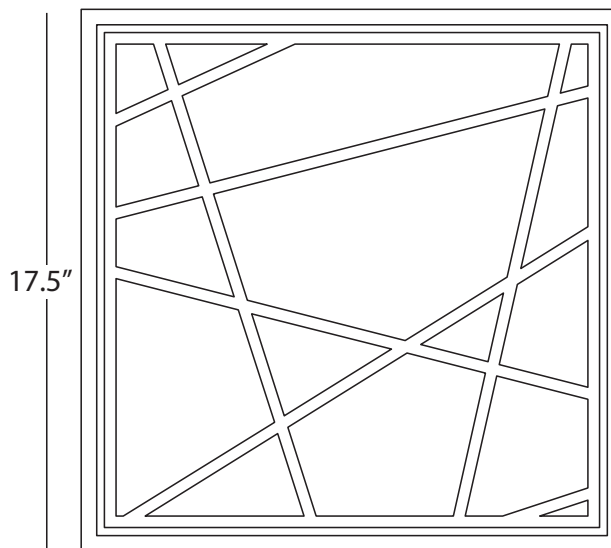
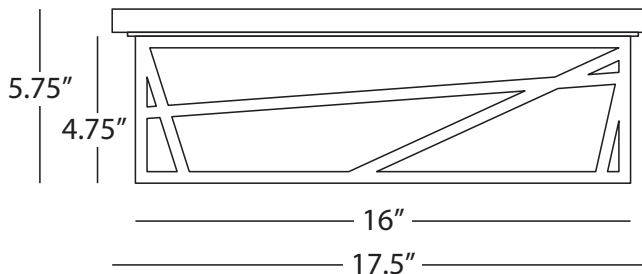

MICHAEL BERMAN BOND

## 533

### Wall Sconce

1 - 100W Max.  
 Bulb Type: A  
 Direct Wire Only  
 Deep Patina Bronze Finish  
 Modern Brass Accents  
 Clear Glass Shade

FINISH/SHADE OPTIONS:

**533W** Deep Patina Bronze/Modern Brass  
 Frosted, Cased, White Glass  
**543** Smoked Walnut/Deep Patina Bronze  
 Clear Glass  
**543W** Smoked Walnut/Deep Patina Bronze  
 Frosted, Cased, White Glass  
**553** Driftwood Oak/Blackened Nickel  
 Clear Glass  
**553W** Driftwood Oak/Blackened Nickel  
 Frosted, Cased, White Glass



S620



Z621



622

# Michael Berman Brut

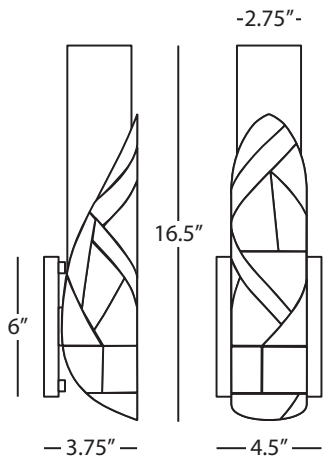

MICHAEL BERMAN BRUT

## S620

### Wall Sconce

1 - 40W Max.  
 Bulb Type: B, Medium Base  
 Direct Wire Only  
 Polished Nickel Finish  
 Frosted Cased White Glass Shade  
 UL Rated for Damp Locations  
 ADA Compliant

FINISH OPTIONS:

- 620** Modern Brass
- Z620** Deep Patina Bronze

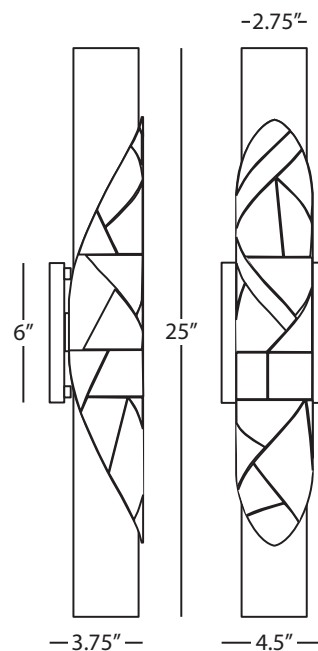

MICHAEL BERMAN BRUT

## Z621

### Double Wall Sconce

2 - 40W Max.  
 Bulb Type: B, Medium Base  
 Direct Wire Only  
 Deep Patina Bronze Finish  
 Frosted Cased White Glass Shades  
 UL Rated for Damp Locations  
 ADA Compliant

FINISH OPTIONS:

- 621** Modern Brass
- S621** Polished Nickel

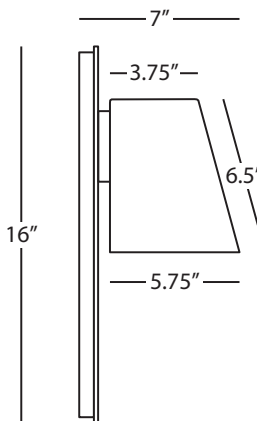
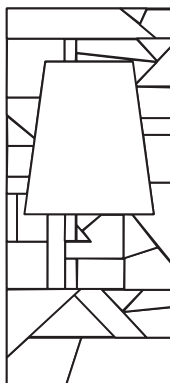
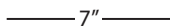
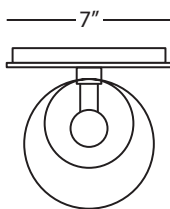

MICHAEL BERMAN BRUT

## 622

### Outdoor Wall Sconce

1 - 60W Max.  
 Bulb Type: A  
 Direct Wire Only  
 Modern Brass Finish  
 Metal Shade  
 UL Rated for Wet Locations

FINISH OPTIONS:

- S622** Polished Nickel
- Z622** Deep Patina Bronze

# Michael Berman Brut



628



S627



Z627

# Michael Berman Brut

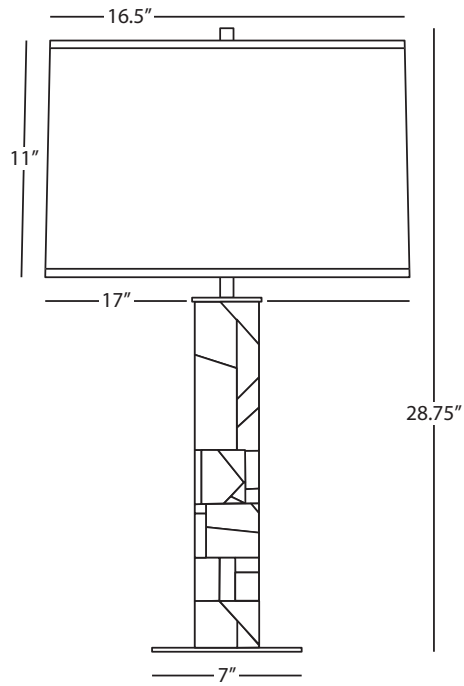

MICHAEL BERMAN BRUT

## S627

### Table Lamp

1 - 150W Max.  
Bulb Type: A  
Switch: Full Range Dimmer  
Polished Nickel Finish  
Ascot White Fabric Shade

#### FINISH OPTIONS:

**627** Modern Brass  
**Z627** Deep Patina Bronze

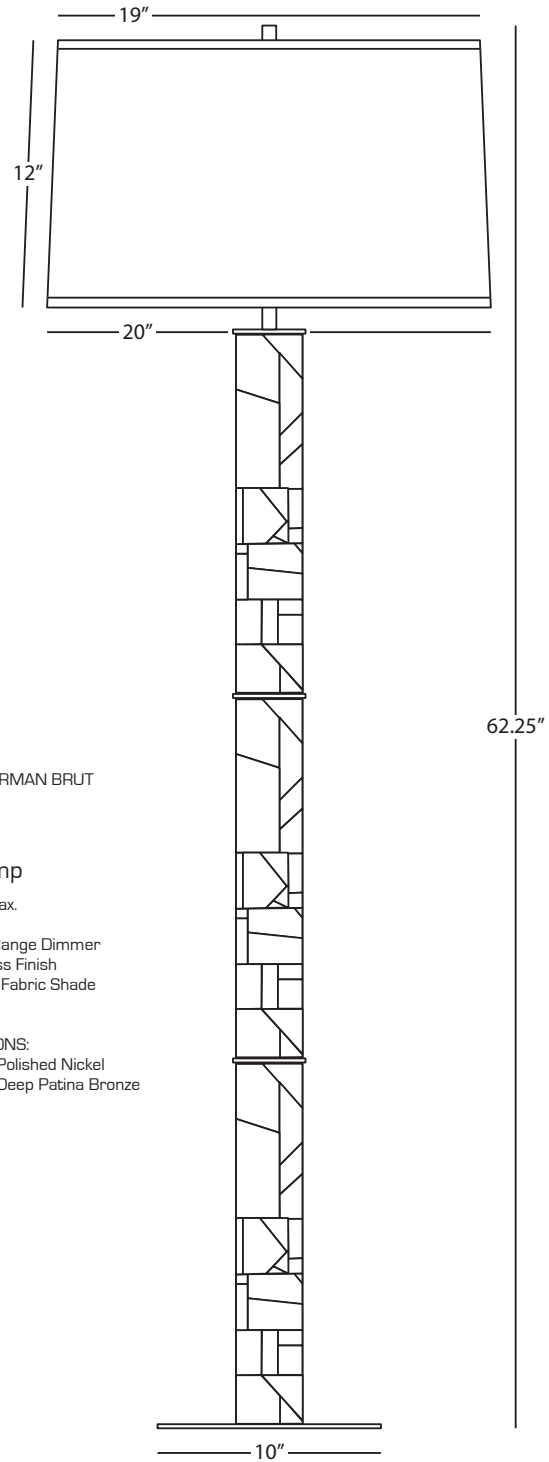

MICHAEL BERMAN BRUT

## 628

### Floor Lamp

1 - 150W Max.  
Bulb Type: A  
Switch: Full Range Dimmer  
Modern Brass Finish  
Ascot White Fabric Shade

#### FINISH OPTIONS:

**S628** Polished Nickel  
**Z628** Deep Patina Bronze



626



Z626



623



S624



# Michael Berman Brut

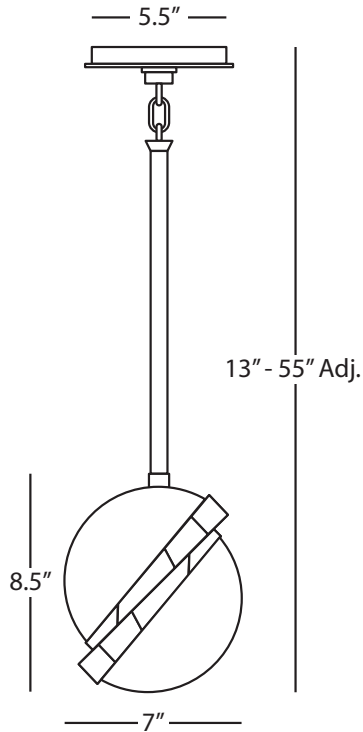

MICHAEL BERMAN BRUT

## S624

### Pendant

1 - 60W Max.  
 Bulb Type: B, Medium Base  
 Direct Wire  
 Polished Nickel Finish  
 Cased White Glass Shade  
 Susp. Hardware: 1 pc. 5/8" x 6" & 3 pcs.  
 5/8" x 12" Extensions

#### FINISH OPTIONS:

**624** Modern Brass  
**Z624** Deep Patina Bronze

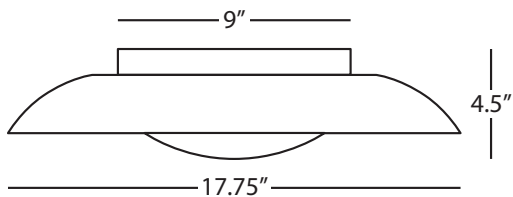

MICHAEL BERMAN BRUT

## 623

### Flush Mount

1 - 60W Max.  
 Bulb Type: B, Medium Base  
 Direct Wire  
 Modern Brass Finish  
 Cased White Glass Shade

#### FINISH OPTIONS:

**S623** Polished Nickel  
**Z623** Deep Patina Bronze

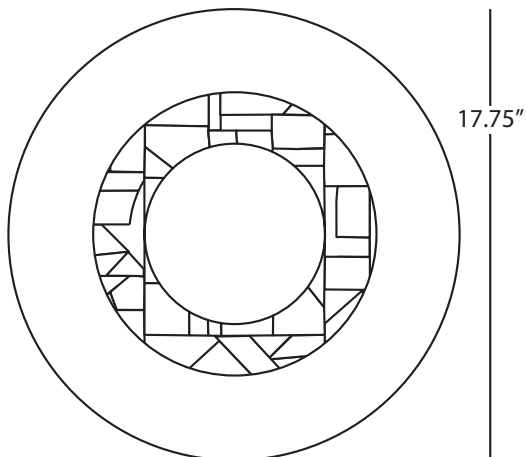
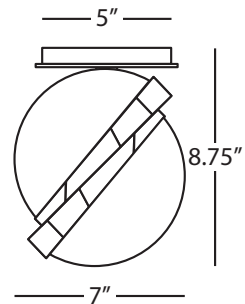

MICHAEL BERMAN BRUT

## 626

### Disc Flush Mount/Sconce

1 - 15W  
 (1200 Lumen Output)  
 Bulb Type: LED unit, Included (Non-replaceable)  
 LED Color Temp: 3000K, CRI: 90  
 Direct Wire Only  
 Modern Brass Finish

#### FINISH OPTIONS:

**S626** Polished Nickel  
**Z626** Deep Patina Bronze



MDC27



MWR26



MDV28



MMB27



MCR26



MSB28

# Michael Berman Hadrian

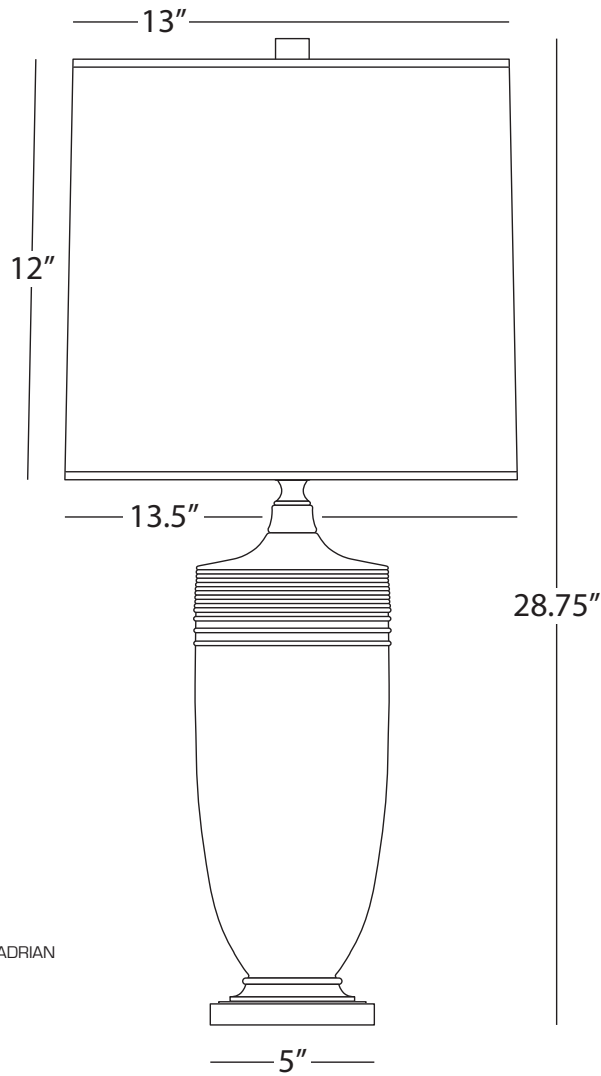

MICHAEL BERMAN HADRIAN

## **MCR26**

### Table Lamp

1 - 150W Max.  
Bulb Type: A  
Switch: Hi-Lo Dimming  
Matte Ash Glazed Ceramic  
Dark Antique Nickel Accents  
Oyster Linen Shade

See Page 239 for Color/Base Options



MDC25



MWR24



MMB23



MLY25



MSB23



MCR24

# Michael Berman Nolan

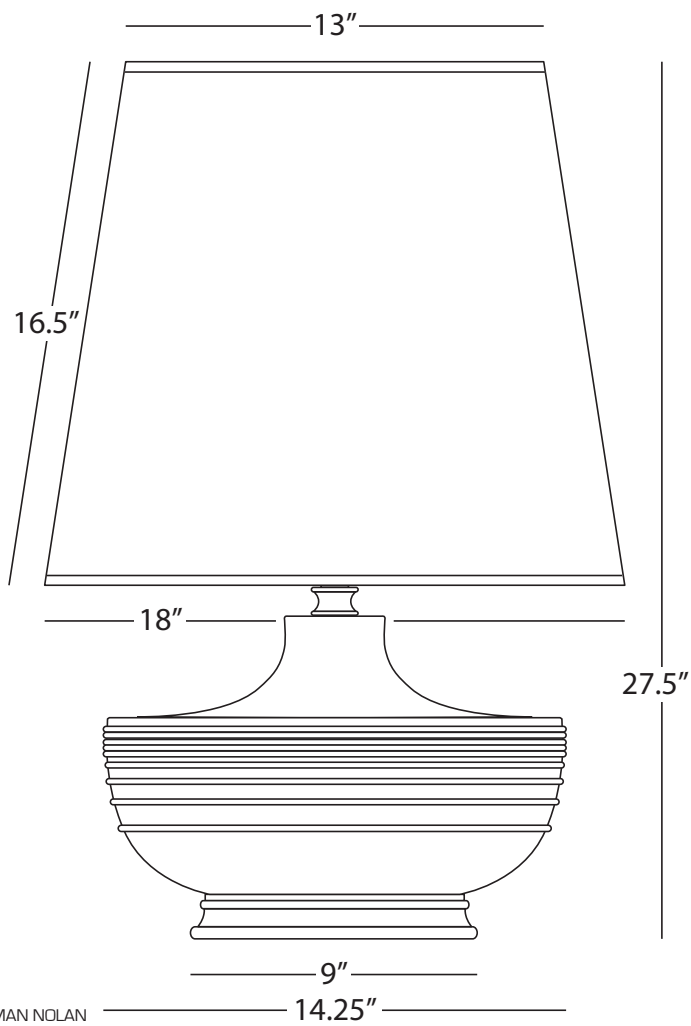

## **MCR24**

### Table Lamp

1 - 150W Max.  
Bulb Type: A  
Switch: Hi-Lo Dimming  
Matte Ash Glazed Ceramic  
Modern Brass Accents  
Oyster Linen Shade

See Page 239 for Color/Base Options



BUL1G



BUL1S



BULG1



BULS1



BUL01



HIS01

# Bulbs

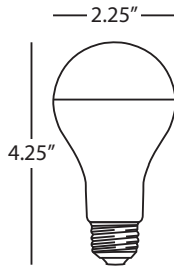

BULBS

### BUL1S

Silver Tip Bulb

1 - 60W  
A19, Medium Base Bulb

OPTION:

**BUL5S** 5 - 40W Silver Tip Bulbs

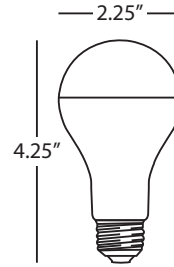

BULBS

### BUL1G

Gold Tip Bulb

1 - 60W  
A19, Medium Base Bulb

OPTION:

**BUL5G** 5 - 40W Gold Tip Bulbs

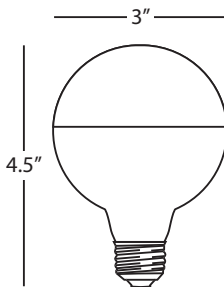

BULBS

### BULS1

Silver Tip Bulb

1 - 40W  
G25, Medium Base Bulb

OPTION:

**BUL6S** 6 - 40W Silver Tip Bulbs

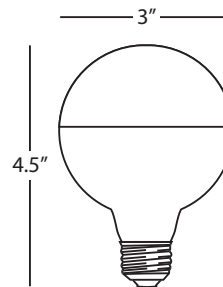

BULBS

### BULG1

Gold Tip Bulb

1 - 40W  
G25, Medium Base Bulb

OPTION:

**BUL6G** 6 - 40W Gold Tip Bulbs

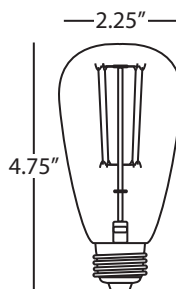

BULBS

### HIS01

Historical Bulb

1 - 40W  
Medium Base  
1910 Squirrel Cage Filament Bulb

OPTIONS:

**BUL06** 6 - 40W Historical Bulbs  
**BUL09** 9 - 40W Historical Bulbs  
**BUL12** 12 - 40W Historical Bulbs  
**BUL18** 18 - 40W Historical Bulbs  
**BUL30** 30 - 40W Historical Bulbs

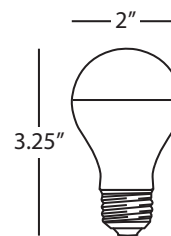

BULBS

### BUL01

Silver Tip Bulb

1 - 60W  
A15, Medium Base Bulb

# Athena | Audrey



## ATHENA TABLE LAMP

● AMETHYST	AM992
● APPLE	AP992
● ASH	CR992
● BABY BLUE	BB992
● BONE	BN992
● BROWN TEA	TE992
● BUTTER	BT992
● CELADON	CL992
● CINNAMON	CM992
● CITRON	CI992
● COFFEE	CF992
● EGG BLUE	EB992
● EMERALD	EG992
○ LILY	LY992
● MARINE BLUE	MR992
● MELON	ML992
● MIDNIGHT BLUE	MB992
● OXBLOOD	OX992
● PEACOCK	PC992
● PUMPKIN	PM992
● RUBY RED	RR992
● SCHIAPARELLI PINK	SP992
● SMOKY TAUPE	ST992
● STEEL BLUE	OB992
● SUNSET YELLOW	SU992

## AUDREY TABLE LAMP

● AMETHYST	AM980
● APPLE	AP980
● ASH	CR980
● BABY BLUE	BB980
● BONE	BN980
● BROWN TEA	TE980
● BUTTER	BT980
● CELADON	CL980
● CINNAMON	CM980
● CITRON	CI980
● COFFEE	CF980
● EGG BLUE	EB980
● EMERALD	EG980
○ LILY	LY980
● MARINE BLUE	MR980
● MELON	ML980
● MIDNIGHT BLUE	MB980
● OXBLOOD	OX980
● PEACOCK	PC980
● PUMPKIN	PM980
● RUBY RED	RR980
● SCHIAPARELLI PINK	SP980
● SMOKY TAUPE	ST980
● STEEL BLUE	OB980
● SUNSET YELLOW	SU980





# Delilah | Delta



## DELILAH TABLE LAMP

● AMETHYST	AM701
● APPLE	AP701
● ASH	CR701
● BABY BLUE	BB701
● BONE	BN701
● BROWN TEA	TE701
● BUTTER	BT701
● CELADON	CL701
● CINNAMON	CM701
● CITRON	CI701
● COFFEE	CF701
● EGG BLUE	EB701
● EMERALD	EG701
○ LILY	LY701
● MARINE BLUE	MR701
● MELON	ML701
● MIDNIGHT BLUE	MB701
● OXBLOOD	OX701
● PEACOCK	PC701
● PUMPKIN	PM701
● RUBY RED	RR701
● SCHIAPARELLI PINK	SP701
● SMOKY TAUPE	ST701
● STEEL BLUE	OB701
● SUNSET YELLOW	SU701

## DELTA TABLE LAMP

● AMETHYST	949
● APPLE	935
● ASH	CR930
● BABY BLUE	936
● BONE	930
● BROWN TEA	TE930
● BUTTER	940
● CELADON	947
● CINNAMON	944
● CITRON	CI930
● COFFEE	CF930
● EGG BLUE	943
● EMERALD	EG930
○ LILY	932
● MARINE BLUE	946
● MELON	ML930
● MIDNIGHT BLUE	MB930
● OXBLOOD	938
● PEACOCK	934
● PUMPKIN	933
● RUBY RED	RR930
● SCHIAPARELLI PINK	941
● SMOKY TAUPE	942
● STEEL BLUE	OB930
● SUNSET YELLOW	SU930





**DOLLY ACCENT LAMP**

● AMETHYST	AM801
● APPLE	AP801
● ASH	CR801
● BABY BLUE	BB801
○ BONE	BN801
● BROWN TEA	TE801
● BUTTER	BT801
● CELADON	CL801
● CINNAMON	CM801
● CITRON	CI801
● COFFEE	CF801
● EGG BLUE	EB801
● EMERALD	EG801
○ LILY	LY801
● MARINE BLUE	MR801
● MELON	ML801
● MIDNIGHT BLUE	MB801
● OXBLOOD	OX801
● PEACOCK	PC801
● PUMPKIN	PM801
● RUBY RED	RR801
● SCHIAPARELLI PINK	SP801
● SMOKY TAUPE	ST801
● STEEL BLUE	OB801
● SUNSET YELLOW	SU801

**DOLLY TABLE LAMP**

● AMETHYST	AM800
● APPLE	AP800
● ASH	CR800
● BABY BLUE	BB800
○ BONE	BN800
● BROWN TEA	TE800
● BUTTER	BT800
● CELADON	CL800
● CINNAMON	CM800
● CITRON	CI800
● COFFEE	CF800
● EGG BLUE	EB800
● EMERALD	EG800
○ LILY	LY800
● MARINE BLUE	MR800
● MELON	ML800
● MIDNIGHT BLUE	MB800
● OXBLOOD	OX800
● PEACOCK	PC800
● PUMPKIN	PM800
● RUBY RED	RR800
● SCHIAPARELLI PINK	SP800
● SMOKY TAUPE	ST800
● STEEL BLUE	OB800
● SUNSET YELLOW	SU800



# Double Gourd



## LARGE DOUBLE GOURD

- AMETHYST
- APPLE
- ASH
- BABY BLUE
- BONE
- BROWN TEA
- BUTTER
- CELADON
- CINNAMON
- CITRON
- COFFEE
- EGG BLUE
- EMERALD
- LILY
- MARINE BLUE
- MELON
- MIDNIGHT BLUE
- OXBLOOD
- PEACOCK
- PUMPKIN
- RUBY RED
- SCHIAPARELLI PINK
- SMOKY TAUPE
- STEEL BLUE
- SUNSET YELLOW



## SMALL DOUBLE GOURD

- AMETHYST
- APPLE
- ASH
- BABY BLUE
- BONE
- BROWN TEA
- BUTTER
- CELADON
- CINNAMON
- CITRON
- COFFEE
- EGG BLUE
- EMERALD
- LILY
- MARINE BLUE
- MELON
- MIDNIGHT BLUE
- OXBLOOD
- PEACOCK
- PUMPKIN
- RUBY RED
- SCHIAPARELLI PINK
- SMOKY TAUPE
- STEEL BLUE
- SUNSET YELLOW

## BRASS BASE

- 1745, 1745X
- 1663, 1663X
- CR20, CR20X
- 1666, 1666X
- 1754, 1754X
- TE20, TE20X
- 1604, 1604X
- 1789, 1789X
- 1757, 1757X
- CI20, CI20X
- CF20, CF20X
- 1740, 1740X
- EG20, EG20X
- 1660, 1660X
- 1783, 1783X
- ML20, ML20X
- MB20, MB20X
- 1667, 1667X
- 1751, 1751X
- 1665, 1665X
- RR20, RR20X
- 1607, 1607X
- 1748, 1748X
- OB20, OB20X
- SU20, SU20X

## BRASS BASE

- 1765, 1765X
- 1683, 1683X
- CR10, CR10X
- 1689, 1689X
- 1774, 1774X
- TE10, TE10X
- 1614, 1614X
- 1786, 1786X
- 1777, 1777X
- CI10, CI10X
- CF10, CF10X
- 1760, 1760X
- EG10, EG10X
- 1680, 1680X
- 1780, 1780X
- ML10, ML10X
- MB10, MB10X
- 1687, 1687X
- 1771, 1771X
- 1685, 1685X
- RR10, RR10X
- 1617, 1617X
- 1768, 1768X
- OB10, OB10X
- SU10, SU10X

## BRONZE BASE

- 1746, 1746X
- 1643, 1643X
- CR21, CR21X
- 1646, 1646X
- 1755, 1755X
- TE21, TE21X
- 1605, 1605X
- 1790, 1790X
- 1758, 1758X
- CI21, CI21X
- CF21, CF21X
- EG21, EG21X
- 1640, 1640X
- ML21, ML21X
- MB21, MB21X
- 1647, 1647X
- 1752, 1752X
- 1645, 1645X
- RR21, RR21X
- 1608, 1608X
- 1749, 1749X
- OB21, OB21X
- SU21, SU21X

## BRONZE BASE

- 1766, 1766X
- 1653, 1653X
- CR11, CR11X
- 1656, 1656X
- 1775, 1775X
- TE11, TE11X
- 1615, 1615X
- 1787, 1787X
- 1778, 1778X
- CI11, CI11X
- CF11, CF11X
- EG11, EG11X
- 1650, 1650X
- ML11, ML11X
- MB11, MB11X
- 1657, 1657X
- 1772, 1772X
- 1655, 1655X
- RR11, RR11X
- 1618, 1618X
- 1769, 1769X
- OB11, OB11X
- SU11, SU11X

## ANT. SILVER BASE

- 1747, 1747X
- 1673, 1673X
- CR22, CR22X
- 1676, 1676X
- 1756, 1756X
- TE22, TE22X
- 1606, 1606X
- 1791, 1791X
- 1759, 1759X
- CI22, CI22X
- CF22, CF22X
- 1741, 1741X
- EG22, EG22X
- 1670, 1670X
- 1785, 1785X
- ML22, ML22X
- MB22, MB22X
- 1753, 1753X
- 1675, 1675X
- RR22, RR22X
- 1609, 1609X
- 1750, 1750X
- OB22, OB22X
- SU22, SU22X

## ANT. SILVER BASE

- 1767, 1767X
- 1693, 1693X
- CR12, CR12X
- 1696, 1696X
- 1776, 1776X
- TE12, TE12X
- 1616, 1616X
- 1788, 1788X
- 1779, 1779X
- CI12, CI12X
- CF12, CF12X
- 1761, 1761X
- EG12, EG12X
- 1690, 1690X
- 1782, 1782X
- ML12, ML12X
- MB12, MB12X
- 1773, 1773X
- 1695, 1695X
- RR12, RR12X
- 1619, 1619X
- 1770, 1770X
- OB12, OB12X
- SU12, SU12X

## LUCITE BASE

- A747, A747X
- A673, A673X
- CR23, CR23X
- A676, A676X
- A756, A756X
- TE23, TE23X
- A606, A606X
- A791, A791X
- A759, A759X
- CI23, CI23X
- CF23, CF23X
- A741, A741X
- EG23, EG23X
- A670, A670X
- A785, A785X
- ML23, ML23X
- MB23, MB23X
- A627, A627X
- A753, A753X
- A675, A675X
- RR23, RR23X
- A609, A609X
- A750, A750X
- OB23, OB23X
- SU23, SU23X

## LUCITE BASE

- A767, A767X
- A693, A693X
- CR13, CR13X
- A696, A696X
- A776, A776X
- TE13, TE13X
- A616, A616X
- A788, A788X
- A779, A779X
- CI13, CI13X
- CF13, CF13X
- A761, A761X
- EG13, EG13X
- A690, A690X
- A782, A782X
- ML13, ML13X
- MB13, MB13X
- A697, A697X
- A773, A773X
- A695, A695X
- RR13, RR13X
- A619, A619X
- A770, A770X
- OB13, OB13X
- SU13, SU13X



## FRANKLIN ACCENT LAMP

● AMETHYST	AM02
● APPLE	AP02
● ASH	CR02
● BABY BLUE	BB02
● BONE	BN02
● BROWN TEA	TE02
● BUTTER	BT02
● CELADON	CL02
● CINNAMON	CM02
● CITRON	CI02
● COFFEE	CF02
● EGG BLUE	EB02
● EMERALD	EG02
○ LILY	LY02
● MARINE BLUE	MR02
● MELON	ML02
● MIDNIGHT BLUE	MB02
● OXBLOOD	OX02
● PEACOCK	PC02
● PUMPKIN	PM02
● RUBY RED	RR02
● SCHIAPARELLI PINK	SP02
● SMOKY TAUPE	ST02
● STEEL BLUE	OB02
● SUNSET YELLOW	SU02

### MATTE COLORS

● MATTE ASH	MCR02
● MATTE CELADON	MCL02
● MATTE COFFEE	MCF02
○ MATTE LILY	MLY02
● MATTE MIDNIGHT BLUE	MMB02
● MATTE SMOKY TAUPE	MST02
● MATTE STEEL BLUE	MOB02

## FRANKLIN TABLE LAMP

● AMETHYST	AM01
● APPLE	AP01
● ASH	CR01
● BABY BLUE	BB01
● BONE	BN01
● BROWN TEA	TE01
● BUTTER	BT01
● CELADON	CL01
● CINNAMON	CM01
● CITRON	CI01
● COFFEE	CF01
● EGG BLUE	EB01
● EMERALD	EG01
○ LILY	LY01
● MARINE BLUE	MR01
● MELON	ML01
● MIDNIGHT BLUE	MB01
● OXBLOOD	OX01
● PEACOCK	PC01
● PUMPKIN	PM01
● RUBY RED	RR01
● SCHIAPARELLI PINK	SP01
● SMOKY TAUPE	ST01
● STEEL BLUE	OB01
● SUNSET YELLOW	SU01

### MATTE COLORS

● MATTE ASH	MCR01
● MATTE CELADON	MCL01
● MATTE COFFEE	MCF01
○ MATTE LILY	MLY01
● MATTE MIDNIGHT BLUE	MMB01
● MATTE SMOKY TAUPE	MST01
● MATTE STEEL BLUE	MOB01



# Fusion | Jasmine



## FUSION TABLE LAMP

● AMETHYST	AM981
● APPLE	AP981
● ASH	CR981
● BABY BLUE	BB981
● BONE	BN981
● BROWN TEA	TE981
● BUTTER	BT981
● CELADON	CL981
● CINNAMON	CM981
● CITRON	CI981
● COFFEE	CF981
● EGG BLUE	EB981
● EMERALD	EG981
○ LILY	LY981
● MARINE BLUE	MR981
● MELON	ML981
● MIDNIGHT BLUE	MB981
● OXBLOOD	OX981
● PEACOCK	PC981
● PUMPKIN	PM981
● RUBY RED	RR981
● SCHIAPARELLI PINK	SP981
● SMOKY TAUPE	ST981
● STEEL BLUE	OB981
● SUNSET YELLOW	SU981

## JASMINE TABLE LAMP

● AMETHYST	AM210
● APPLE	AP210
● ASH	CR210
● BABY BLUE	BB210
● BONE	BN210
● BROWN TEA	TE210
● BUTTER	BT210
● CELADON	CL210
● CINNAMON	CM210
● CITRON	CI210
● COFFEE	CF210
● EGG BLUE	EB210
● EMERALD	EG210
○ LILY	LY210
● MARINE BLUE	MR210
● MELON	ML210
● MIDNIGHT BLUE	MB210
● OXBLOOD	OX210
● PEACOCK	PC210
● PUMPKIN	PM210
● RUBY RED	RR210
● SCHIAPARELLI PINK	SP210
● SMOKY TAUPE	ST210
● STEEL BLUE	OB210
● SUNSET YELLOW	SU210





## HARVEY ACCENT LAMP

● AMETHYST	AM990
● APPLE	AP990
● ASH	CR990
● BABY BLUE	BB990
● BONE	BN990
● BROWN TEA	TE990
● BUTTER	BT990
● CELADON	CL990
● CINNAMON	CM990
● CITRON	CI990
● COFFEE	CF990
● EGG BLUE	EB990
● EMERALD	EG990
○ LILY	LY990
● MARINE BLUE	MR990
● MELON	ML990
● MIDNIGHT BLUE	MB990
● OXBLOOD	OX990
● PEACOCK	PC990
● PUMPKIN	PM990
● RUBY RED	RR990
● SCHIAPARELLI PINK	SP990
● SMOKY TAUPE	ST990
● STEEL BLUE	OB990
● SUNSET YELLOW	SU990

## HARVEY TABLE LAMP

● AMETHYST	AM995
● APPLE	AP995
● ASH	CR995
● BABY BLUE	BB995
● BONE	BN995
● BROWN TEA	TE995
● BUTTER	BT995
● CELADON	CL995
● CINNAMON	CM995
● CITRON	CI995
● COFFEE	CF995
● EGG BLUE	EB995
● EMERALD	EG995
○ LILY	LY995
● MARINE BLUE	MR995
● MELON	ML995
● MIDNIGHT BLUE	MB995
● OXBLOOD	OX995
● PEACOCK	PC995
● PUMPKIN	PM995
● RUBY RED	RR995
● SCHIAPARELLI PINK	SP995
● SMOKY TAUPE	ST995
● STEEL BLUE	OB995
● SUNSET YELLOW	SU995





## JUNE ACCENT LAMP

- AMETHYST
- APPLE
- ASH
- BABY BLUE
- BONE
- BROWN TEA
- BUTTER
- CELADON
- CINNAMON
- CITRON
- COFFEE
- EGG BLUE
- EMERALD
- LILY
- MARINE BLUE
- MELON
- MIDNIGHT BLUE
- OXBLOOD
- PEACOCK
- PUMPKIN
- RUBY RED
- SCHIAPARELLI PINK
- SMOKY TAUPE
- STEEL BLUE
- SUNSET YELLOW

### BUFF SHADE

- AM91
- AP91
- CR91
- BB91
- BN91
- TE91
- BT91
- CL91
- CM91
- CI91
- CF91
- EB91
- EG91
- LY91
- MR91
- ML91
- MB91
- OX91
- PC91
- PM91
- RR91
- SP91
- ST91
- OB91
- SU91

### OYSTER SHADE

- AM93
- AP93
- CR93
- BB93
- BN93
- TE93
- BT93
- CL93
- CM93
- CI93
- CF93
- EB93
- EG93
- LY93
- MR93
- ML93
- MB93
- OX93
- PC93
- PM93
- RR93
- SP93
- ST93
- OB93
- SU93

## JUNE TABLE LAMP

- AMETHYST
- APPLE
- ASH
- BABY BLUE
- BONE
- BROWN TEA
- BUTTER
- CELADON
- CINNAMON
- CITRON
- COFFEE
- EGG BLUE
- EMERALD
- LILY
- MARINE BLUE
- MELON
- MIDNIGHT BLUE
- OXBLOOD
- PEACOCK
- PUMPKIN
- RUBY RED
- SCHIAPARELLI PINK
- SMOKY TAUPE
- STEEL BLUE
- SUNSET YELLOW

### BUFF SHADE

- AM991
- AP991
- CR991
- BB991
- BN991
- TE991
- BT991
- CL991
- CM991
- CI991
- CF991
- EB991
- EG991
- LY991
- MR991
- ML991
- MB991
- OX991
- PC991
- PM991
- RR991
- SP991
- ST991
- OB991
- SU991

### OYSTER SHADE

- AM993
- AP993
- CR993
- BB993
- BN993
- TE993
- BT993
- CL993
- CM993
- CI993
- CF993
- EB993
- EG993
- LY993
- MR993
- ML993
- MB993
- OX993
- PC993
- PM993
- RR993
- SP993
- ST993
- OB993
- SU993





**MASON TABLE LAMP**

● AMETHYST	979
● APPLE	965
● ASH	CR960
● BABY BLUE	966
● BONE	960
● BROWN TEA	TE960
● BUTTER	970
● CELADON	977
● CINNAMON	974
● CITRON	CI960
● COFFEE	CF960
● EGG BLUE	973
● EMERALD	EG960
○ LILY	962
● MARINE BLUE	976
● MELON	ML960
● MIDNIGHT BLUE	MB960
● OXBLOOD	968
● PEACOCK	964
● PUMPKIN	963
● RUBY RED	RR960
● SCHIAPARELLI PINK	971
● SMOKY TAUPE	972
● STEEL BLUE	OB960
● SUNSET YELLOW	SU960







## ORION ACCENT LAMP

● AMETHYST	AM989
● APPLE	AP989
● ASH	CR989
● BABY BLUE	BB989
● BONE	BN989
● BROWN TEA	TE989
● BUTTER	BT989
● CELADON	CL989
● CINNAMON	CM989
● CITRON	CI989
● COFFEE	CF989
● EGG BLUE	EB989
● EMERALD	EG989
○ LILY	LY989
● MARINE BLUE	MR989
● MELON	ML989
● MIDNIGHT BLUE	MB989
● OXBLOOD	OX989
● PEACOCK	PC989
● PUMPKIN	PM989
● RUBY RED	RR989
● SCHIAPARELLI PINK	SP989
● SMOKY TAUPE	ST989
● STEEL BLUE	OB989
● SUNSET YELLOW	SU989

### MATTE COLORS

● MATTE ASH	MCR18
● MATTE CELADON	MCL18
● MATTE COFFEE	MCF18
○ MATTE LILY	MLY18
● MATTE MIDNIGHT BLUE	MMB18
● MATTE SMOKY TAUPE	MST18
● MATTE STEEL BLUE	MOB18

## ORION TABLE LAMP

● AMETHYST	AM999
● APPLE	AP999
● ASH	CR999
● BABY BLUE	BB999
● BONE	BN999
● BROWN TEA	TE999
● BUTTER	BT999
● CELADON	CL999
● CINNAMON	CM999
● CITRON	CI999
● COFFEE	CF999
● EGG BLUE	EB999
● EMERALD	EG999
○ LILY	LY999
● MARINE BLUE	MR999
● MELON	ML999
● MIDNIGHT BLUE	MB999
● OXBLOOD	OX999
● PEACOCK	PC999
● PUMPKIN	PM999
● RUBY RED	RR999
● SCHIAPARELLI PINK	SP999
● SMOKY TAUPE	ST999
● STEEL BLUE	OB999
● SUNSET YELLOW	SU999

### MATTE COLORS

● MATTE ASH	MCR17
● MATTE CELADON	MCL17
● MATTE COFFEE	MCF17
○ MATTE LILY	MLY17
● MATTE MIDNIGHT BLUE	MMB17
● MATTE SMOKY TAUPE	MST17
● MATTE STEEL BLUE	MOB17





**PIKE TABLE LAMP  
(BRASS BASE)**

● AMETHYST	AM994
● APPLE	AP994
● ASH	CR994
● BABY BLUE	BB994
● BONE	BN994
● BROWN TEA	TE994
● BUTTER	BT994
● CELADON	CL994
● CINNAMON	CM994
● CITRON	CI994
● COFFEE	CF994
● EGG BLUE	EB994
● EMERALD	EG994
○ LILY	LY994
● MARINE BLUE	MR994
● MELON	ML994
● MIDNIGHT BLUE	MB994
● OXBLOOD	OX994
● PEACOCK	PC994
● PUMPKIN	PM994
● RUBY RED	RR994
● SCHIAPARELLI PINK	SP994
● SMOKY TAUPE	ST994
● STEEL BLUE	OB994
● SUNSET YELLOW	SU994

**PIKE TABLE LAMP  
(ACRYLIC BASE)**

● AMETHYST	AM996
● APPLE	AP996
● ASH	CR996
● BABY BLUE	BB996
● BONE	BN996
● BROWN TEA	TE996
● BUTTER	BT996
● CELADON	CL996
● CINNAMON	CM996
● CITRON	CI996
● COFFEE	CF996
● EGG BLUE	EB996
● EMERALD	EG996
○ LILY	LY996
● MARINE BLUE	MR996
● MELON	ML996
● MIDNIGHT BLUE	MB996
● OXBLOOD	OX996
● PEACOCK	PC996
● PUMPKIN	PM996
● RUBY RED	RR996
● SCHIAPARELLI PINK	SP996
● SMOKY TAUPE	ST996
● STEEL BLUE	OB996
● SUNSET YELLOW	SU996



# Triple Gourd

LARGE TRIPLE GOURD	BRASS BASE	BRONZE BASE	ANT. SILVER BASE	LUCITE BASE
● AMETHYST	381X	382X	383X	A383X
● APPLE	313X	333X	353X	A353X
● ASH	CR40X	CR41X	CR42X	CR43X
● BABY BLUE	321X	341X	361X	A361X
● BONE	324X	344X	364X	A364X
● BROWN TEA	TE40X	TE41X	TE42X	TE43X
● BUTTER	317X	337X	357X	A357X
● CELADON	369X	370X	371X	A371X
● CINNAMON	325X	345X	365X	A365X
● CITRON	CI40X	CI41X	CI42X	CI43X
● COFFEE	CF40X	CF41X	CF42X	CF43X
● EGG BLUE	322X		362X	A362X
● EMERALD	EG40X	EG41X	EG42X	EG43X
○ LILY	311X	331X	351X	A351X
● MARINE BLUE	366X		368X	A368X
● MELON	ML40X	ML41X	ML42X	ML43X
● MIDNIGHT BLUE	MB40X	MB41X	MB42X	MB43X
● OXBLOOD	315X	335X		A355X
● PEACOCK	323X	343X	363X	A363X
● PUMPKIN	312X	332X	352X	A352X
● RUBY RED	RR40X	RR41X	RR42X	RR43X
● SCHIAPARELLI PINK	318X	338X	358X	A358X
● SMOKY TAUPE	319X	339X	359X	A359X
● STEEL BLUE	OB40X	OB41X	OB42X	OB43X
● SUNSET YELLOW	SU40X	SU41X	SU42X	SU43X

SMALL TRIPLE GOURD	BRASS BASE	BRONZE BASE	ANT. SILVER BASE	LUCITE BASE
● AMETHYST	378X	379X	380X	A380X
● APPLE	243X	263X	283X	A283X
● ASH	CR30X	CR31X	CR32X	CR33X
● BABY BLUE	251X	271X	291X	A291X
● BONE	254X	274X	294X	A294X
● BROWN TEA	TE30X	TE31X	TE32X	TE33X
● BUTTER	247X	267X	287X	A287X
● CELADON	256X	257X	258X	A258X
● CINNAMON	255X	275X	295X	A295X
● CITRON	CI30X	CI31X	CI32X	CI33X
● COFFEE	CF30X	CF31X	CF32X	CF33X
● EGG BLUE	252X		292X	A292X
● EMERALD	EG30X	EG31X	EG32X	EG33X
○ LILY	241X	261X	281X	A281X
● MARINE BLUE	296X		298X	A298X
● MELON	ML30X	ML31X	ML32X	ML33X
● MIDNIGHT BLUE	MB30X	MB31X	MB32X	MB33X
● OXBLOOD	245X	265X		A285X
● PEACOCK	253X	273X	293X	A293X
● PUMPKIN	242X	262X	282X	A282X
● RUBY RED	RR30X	RR31X	RR32X	RR33X
● SCHIAPARELLI PINK	248X	268X	288X	A288X
● SMOKY TAUPE	249X	269X	289X	A289X
● STEEL BLUE	OB30X	OB31X	OB32X	OB33X
● SUNSET YELLOW	SU30X	SU31X	SU32X	SU33X





**VICTOR TABLE LAMP**

- |                     |      |
|---------------------|------|
| ● AMETHYST          | AM03 |
| ● APPLE             | AP03 |
| ● ASH               | CR03 |
| ● BABY BLUE         | BB03 |
| ● BONE              | BN03 |
| ● BROWN TEA         | TE03 |
| ● BUTTER            | BT03 |
| ● CELADON           | CL03 |
| ● CINNAMON          | CM03 |
| ● CITRON            | CI03 |
| ● COFFEE            | CF03 |
| ● EGG BLUE          | EB03 |
| ● EMERALD           | EG03 |
| ○ LILY              | LY03 |
| ● MARINE BLUE       | MR03 |
| ● MELON             | ML03 |
| ● MIDNIGHT BLUE     | MB03 |
| ● OXBLOOD           | OX03 |
| ● PEACOCK           | PC03 |
| ● PUMPKIN           | PM03 |
| ● RUBY RED          | RR03 |
| ● SCHIAPARELLI PINK | SP03 |
| ● SMOKY TAUPE       | ST03 |
| ● STEEL BLUE        | OB03 |
| ● SUNSET YELLOW     | SU03 |



# Atlas



- MATTE ASH
- MATTE DARK COAL
- MATTE DOVE
- MATTE LILY
- MATTE MIDNIGHT BLUE
- MATTE SKY BLUE
- MATTE WOODROSE

### BRASS BASE

- MCR21
- MDC21
- MDV21
- MLY21
- MMB21
- MSB21
- MWR21

### BRONZE BASE

- MCR22
- MDC22
- MDV22
- MLY22
- MMB22
- MSB22
- MWR22

### ANTIQUE NICKEL BASE

- MCR20
- MDC20
- MDV20
- MLY20
- MMB20
- MSB20
- MWR20

# Hadrian



- MATTE ASH
- MATTE DARK COAL
- MATTE DOVE
- MATTE LILY
- MATTE MIDNIGHT BLUE
- MATTE SKY BLUE
- MATTE WOODROSE

### BRASS BASE

- MCR27
- MDC27
- MDV27
- MLY27
- MMB27
- MSB27
- MWR27

### BRONZE BASE

- MCR28
- MDC28
- MDV28
- MLY28
- MMB28
- MSB28
- MWR28

### ANTIQUE NICKEL BASE

- MCR26
- MDC26
- MDV26
- MLY26
- MMB26
- MSB26
- MWR26

# Nolan



- MATTE ASH
- MATTE DARK COAL
- MATTE DOVE
- MATTE LILY
- MATTE MIDNIGHT BLUE
- MATTE SKY BLUE
- MATTE WOODROSE

### BRASS BASE

- MCR24
- MDC24
- MDV24
- MLY24
- MMB24
- MSB24
- MWR24

### BRONZE BASE

- MCR25
- MDC25
- MDV25
- MLY25
- MMB25
- MSB25
- MWR25

### ANTIQUE NICKEL BASE

- MCR23
- MDC23
- MDV23
- MLY23
- MMB23
- MSB23
- MWR23

# Terms and Conditions

Our acceptance of any order is made conditional on the buyer's agreement to the terms and conditions as stated herein.

## Terms

- Proforma invoices are available. The order will be entered and scheduled for production upon receipt of funds.
- Open account terms are net 30 days of invoice (no cash anticipation discounts).
- Slow payments will delay shipments.
- We do not ship C.O.D. under any circumstances.
- Accounts must maintain a minimum annual volume to remain an active account and receive wholesale pricing.

## Ordering

- A minimum opening order is required to establish an account. Please check with your local Sale Rep.
- Clearly mark "confirmation do not duplicate" on orders previously called or faxed to prevent duplication.
- Unless otherwise stated, all back orders will be cancelled.
- Custom items meeting minimums will require a 50% deposit and balance before delivery.
- Orders are entered based on the style number on the order, not the description.

## Quick Ship

- Quick ship items are shipped within 2-3 business days after the order date (based upon stock availability). Check with your local Sales Rep or [www.robertabbey.com](http://www.robertabbey.com) for shipping lead times on each style.
- Quick Ship items are designated on the Robert Abbey price list.
- Cancellations of Quick Ship orders must be made within 24 hours of order placement.
- Non-Quick Ship orders usually ship within 1-2 weeks after order date (based upon stock availability).

## Rush Orders

- We offer an expedited service on small quantities (2 pieces maximum) for rush orders on Non-Quick Ship items.
- If the components are available, we can ship the items within 5-7 business days, with payment of a \$50 expedited production fee for each 2 pieces. This service applies to small rush orders only.

## Shipping & Handling

- **No Drop Ship Fee.**
- All shipments are F.O.B. Factory Hickory, North Carolina.
- All freight is sent freight collect, unless otherwise negotiated.
- Seller assumes no responsibility for damage in transit.
- Most UPS and FedEx Ground shipments are sent prepaid and added to the customer's invoice. (There may be exceptions.)
- Robert Abbey will ship best and cheapest unless otherwise directed.
- Note that other fees may apply to the base rate such as Inside Deliveries, Residential Delivery, and Liftgate service.

## Cancellations

- Orders in production cannot be canceled.
- Contact your local Sales Rep or customer service at Robert Abbey for all cancellations.

## Deductions

- No deductions allowed without prior authorization from Robert Abbey.

## Exchanges & Returns

- Robert Abbey requires all products to be returned to us within 30 days within the original packaging.
- Initial shipping charges are not refundable.
- Authorized returns to Robert Abbey will be charged a 20% restocking fee and return freight is paid by the customer.
- Returns will be applied as a credit to the account.
- Any product returned to Robert Abbey without prior authorization will receive a 30% restocking fee upon receipt.

## Warranty & Damages

- All Damages must be reported to Robert Abbey within 30 days of delivery to file a claim. No claims will be accepted after 30 days.
- Robert Abbey offers a 365-day limited warranty from date of purchase against defects in materials, workmanship, wiring, and internal rewiring. Defects due to improper care, handling, maintenance, and improper assembly or installation will void any warranty claims.



**FACTORY & CORPORATE OFFICE**

3166 Main Avenue SE, Hickory, NC 28601  
Phone: 828.322.3480 Fax: 828.328.1037

[www.robertabbey.com](http://www.robertabbey.com)

**PERMANENT SHOWROOMS**

Hight Point, NC IHFC W244  
Dallas, TX WTC 305-1

